



IGS

INGENIEURGESELLSCHAFT
STOLZ mbH

13. September 2019
Wallfahrtsstadt Werl

STADTGERECHTES VERKEHRSNETZ

Anhang zum Bericht

Projekt 17N049

STADTGERECHTES VERKEHRSNETZ

Konzept für die verkehrswichtigen Straßen in der Wallfahrtsstadt Werl

Erstellt im Auftrag der Wallfahrtsstadt Werl

Fachbereich Planen, Bauen und Umwelt
Hedwig-Dransfeld-Str. 23, 59457 Werl

Bearbeitung

Dr.-Ing. Jeanette Klemmer
Regina Funke-Akbiyik
Michael Vieten

Projektdaten

Laufzeit: NOV 2017 – SEP 2019
Stand: 13.09.2019

Aus Gründen der leichteren Lesbarkeit wird im vorliegenden Text die gewohnte männliche Sprachform verwendet. Dies impliziert jedoch keine Benachteiligung anderer Geschlechter, sondern soll im Sinne der sprachlichen Vereinfachung als geschlechtsneutral zu verstehen sein.

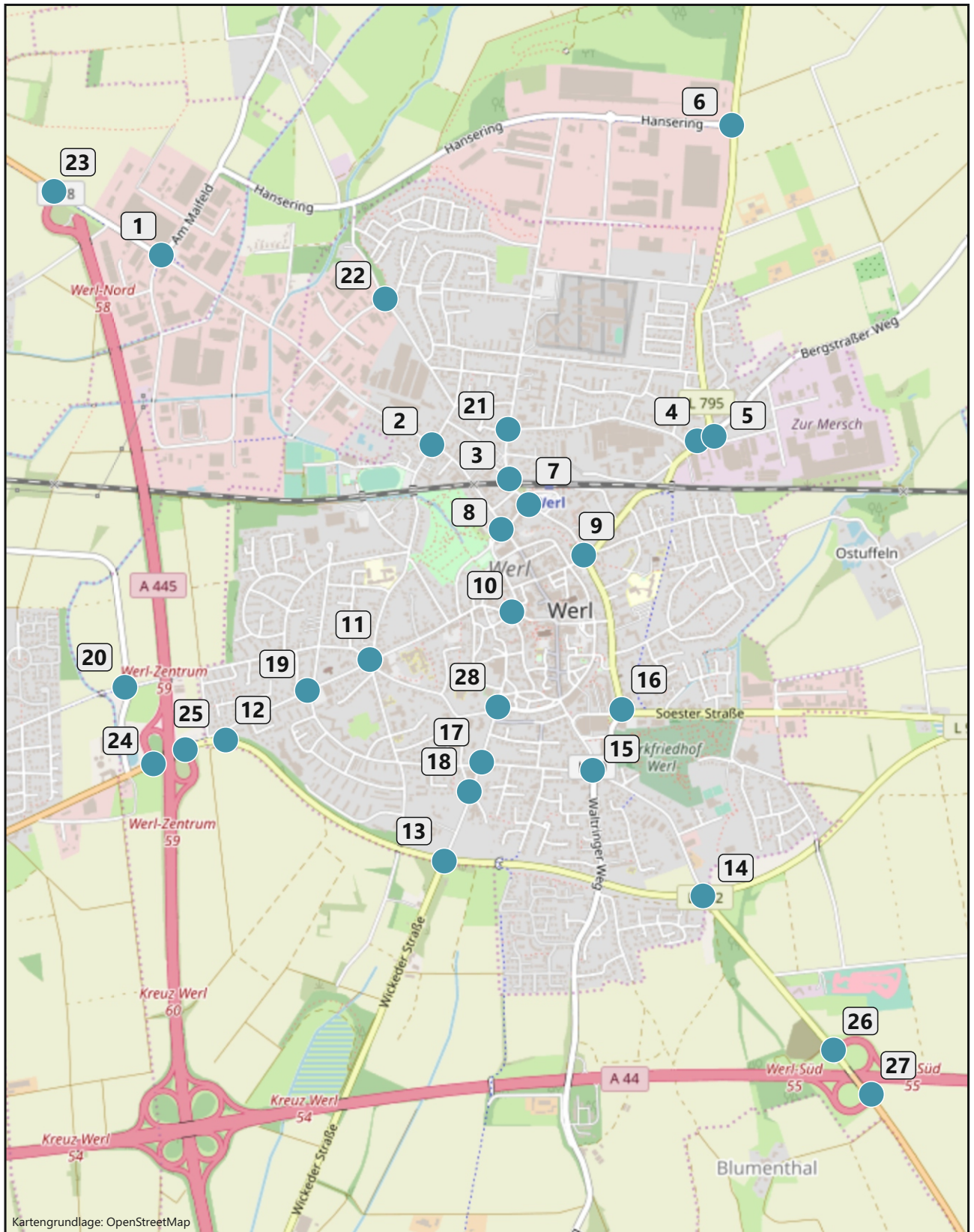

Stadtgerechtes Verkehrsnetz Werl

Lage der Zählstellen

Legende der nachfolgenden Knotenstromdarstellungen

Kfz = alle Kraftfahrzeuge inkl. Schwerverkehr
SV = Schwerverkehr

17N049-07/2019

01 - Hammer Landstr. / Am Maifeld

28.11.2017
07:00 - 08:00 Uhr
Morgenspitze
Kfz (SV)

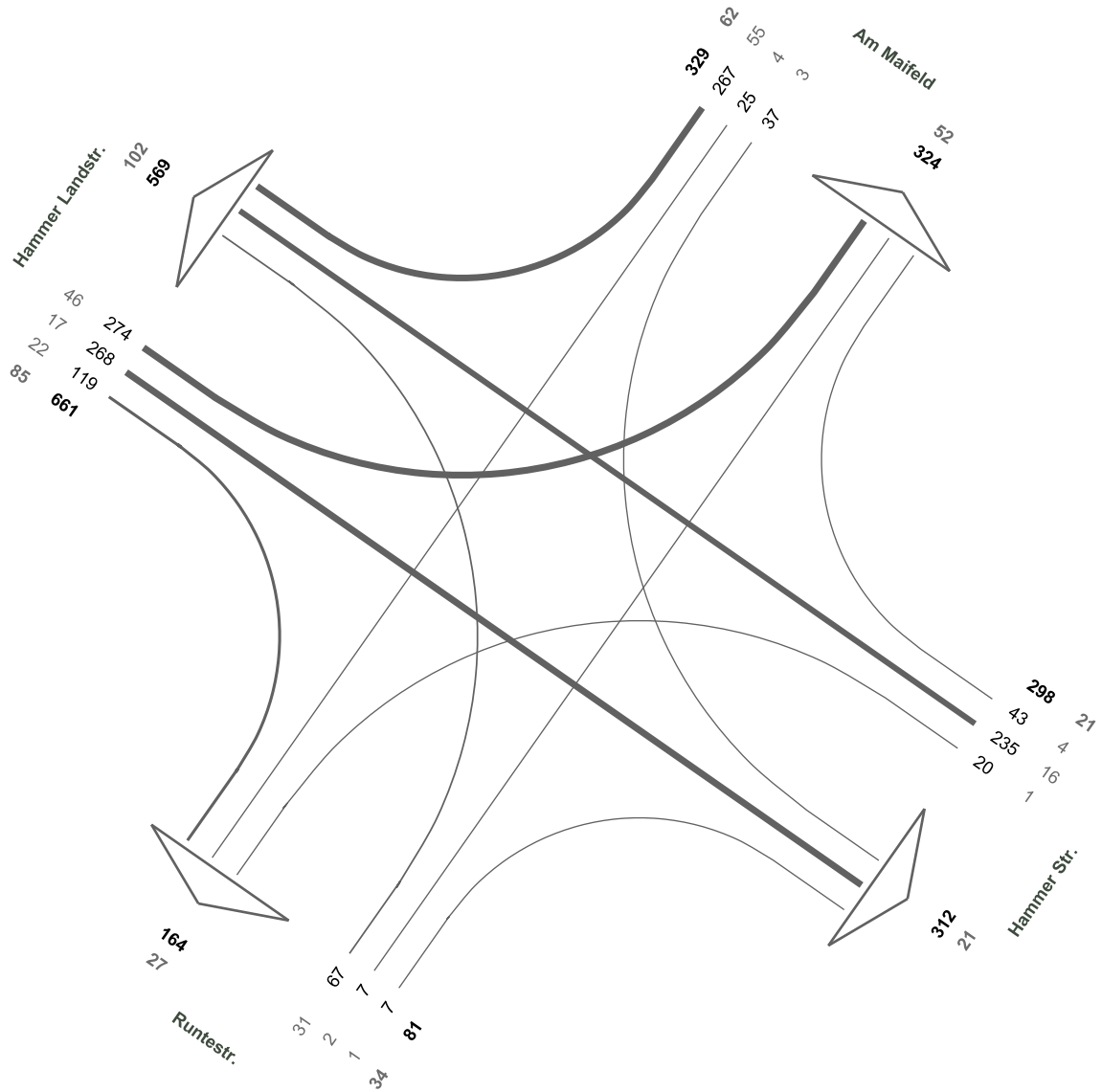

01 - Hammer Landstr. / Am Maifeld

28.11.2017
06:00 - 10:00 Uhr
4-h-Block
Kfz (SV)

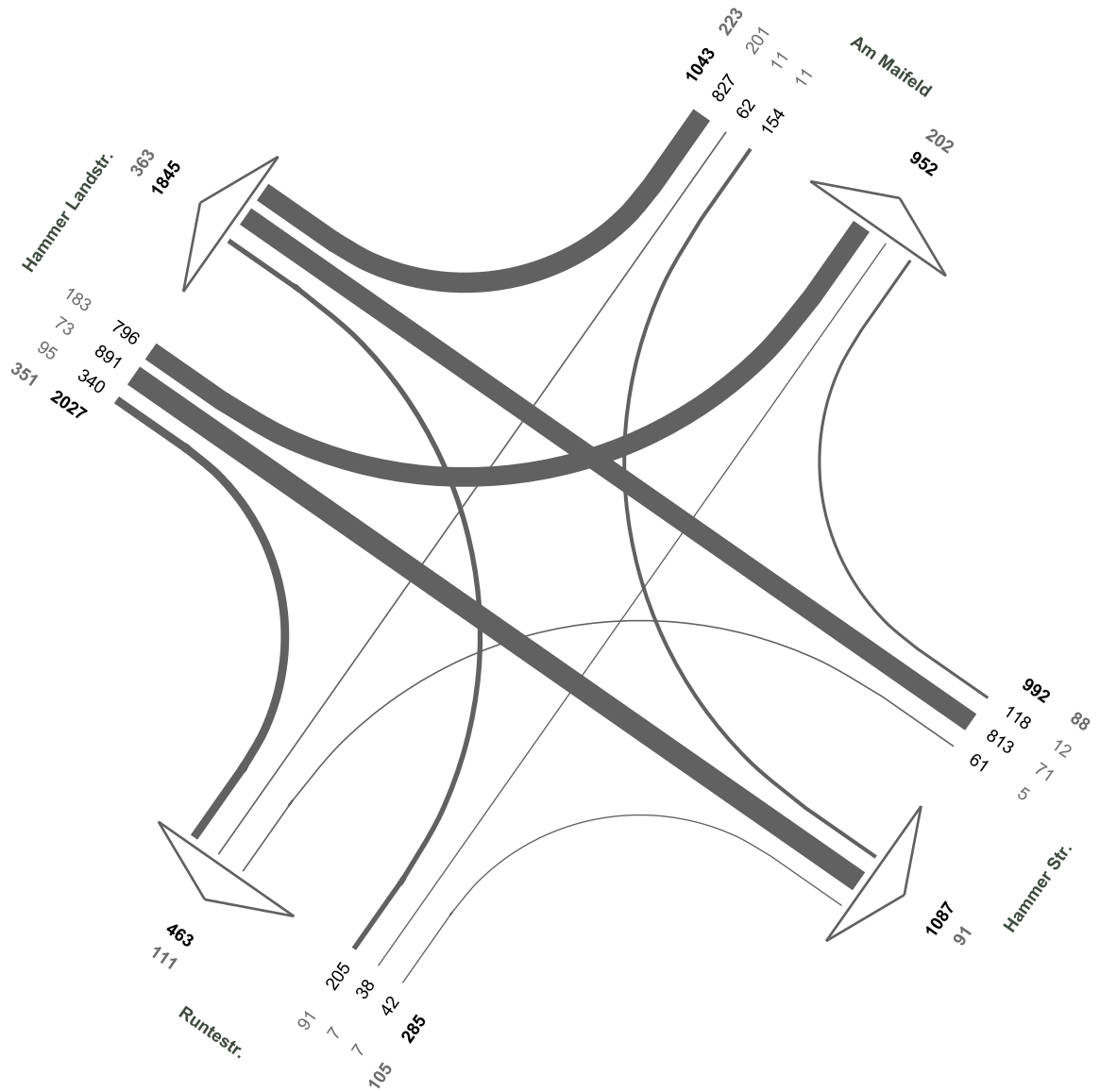

01 - Hammer Landstr. / Am Maifeld

28.11.2017
15:00 - 16:00 Uhr
Abendspitze
Kfz (SV)

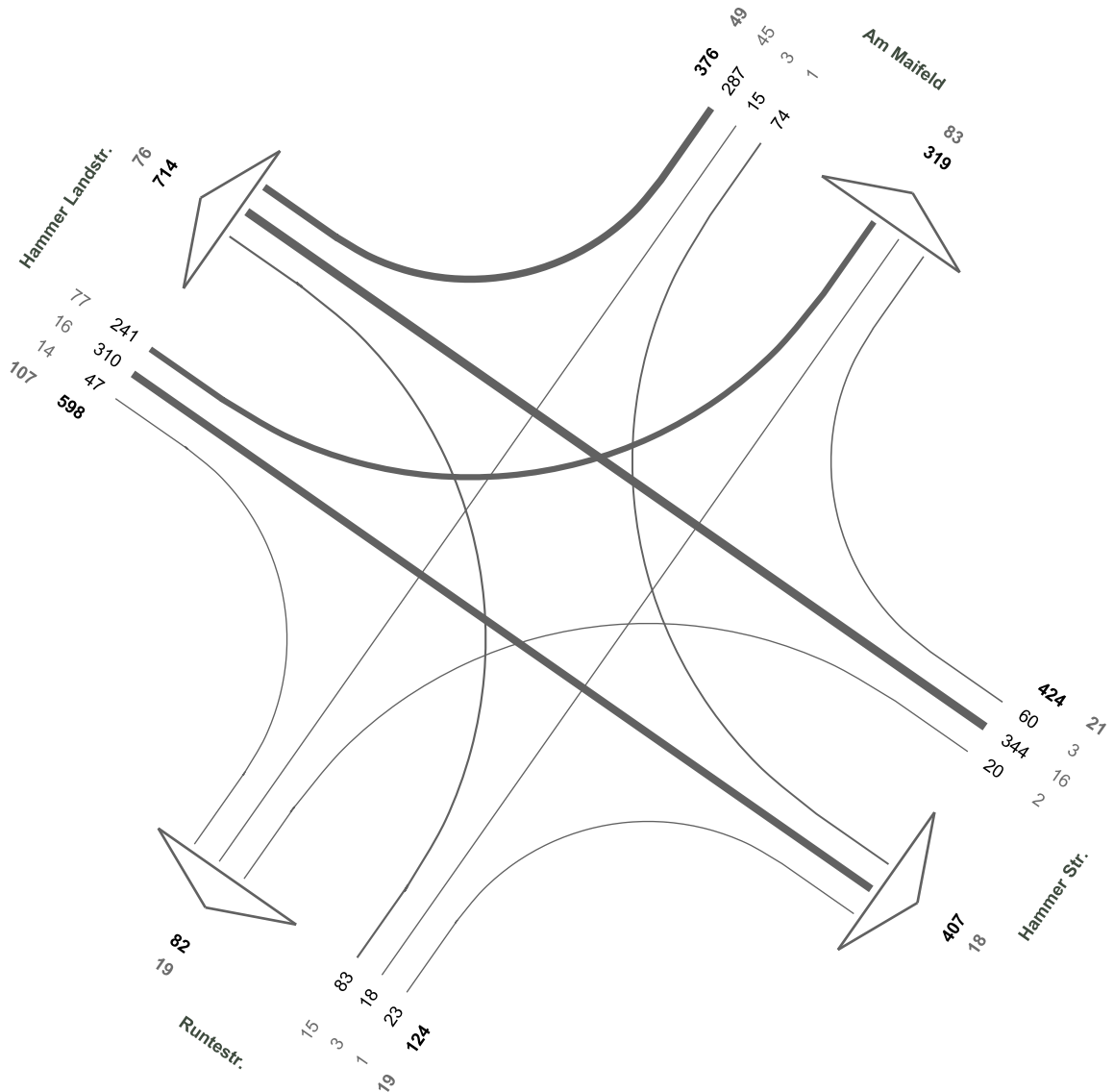

01 - Hammer Landstr. / Am Maifeld

28.11.2017
15:00 - 19:00 Uhr
4-h-Block
Kfz (SV)

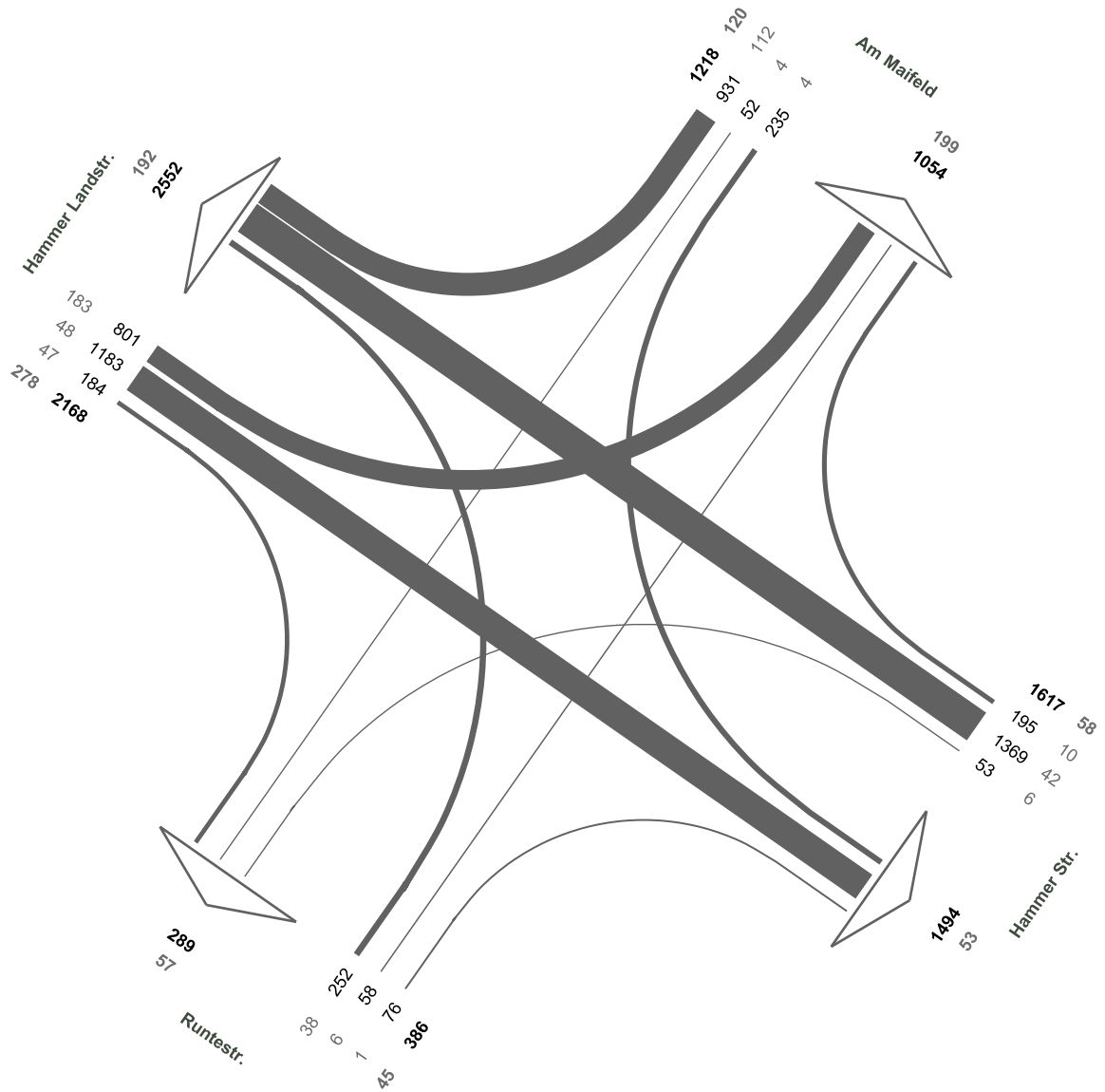

02 - Hammer Str. / Rustigestr. / Salinenring

28.11.2017
07:15 - 08:15 Uhr
Morgenspitze
Kfz (SV)

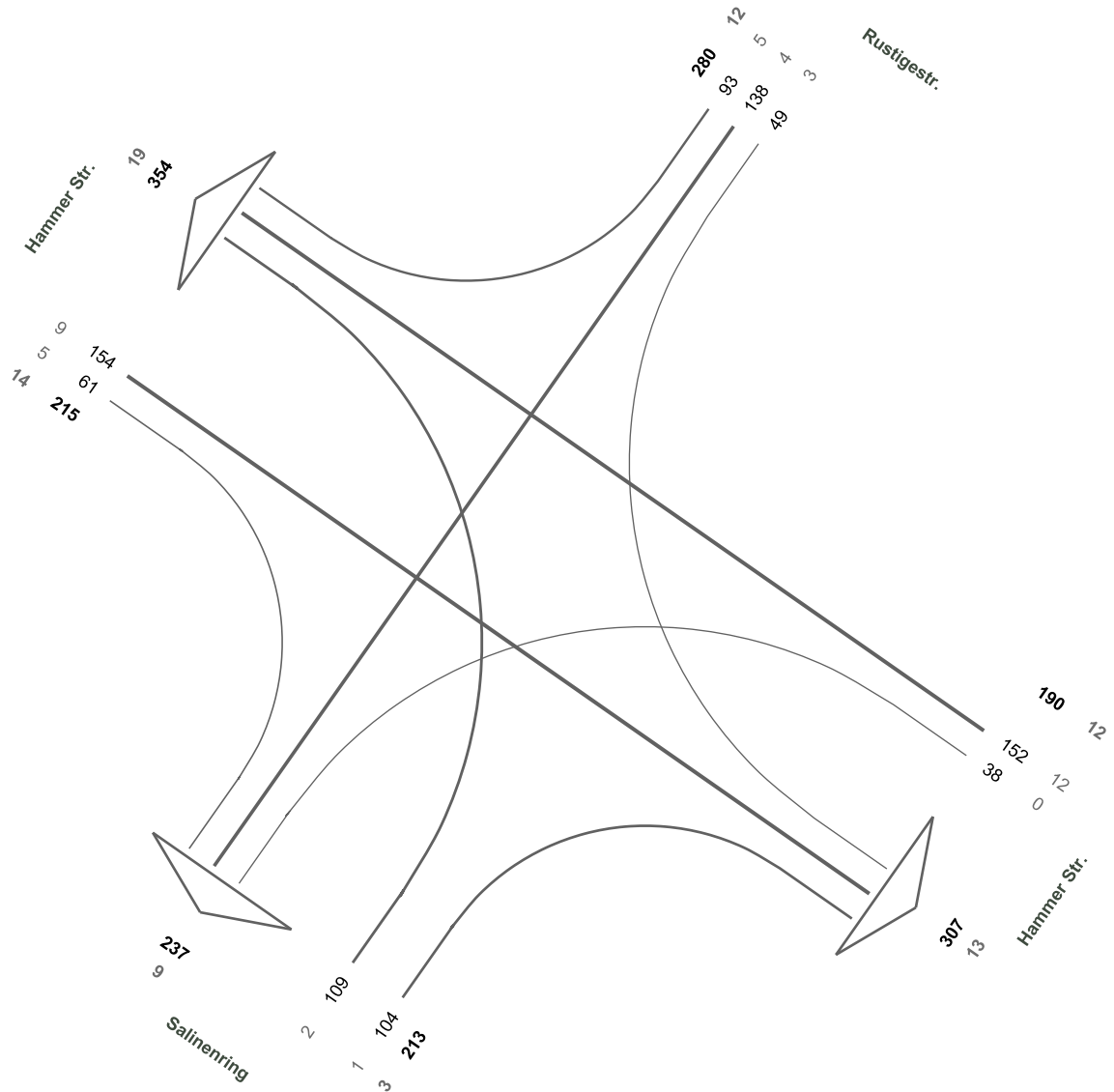

02 - Hammer Str. / Rustigestr. / Salinenring

28.11.2017
06:00 - 10:00 Uhr
4-h-Block
Kfz (SV)

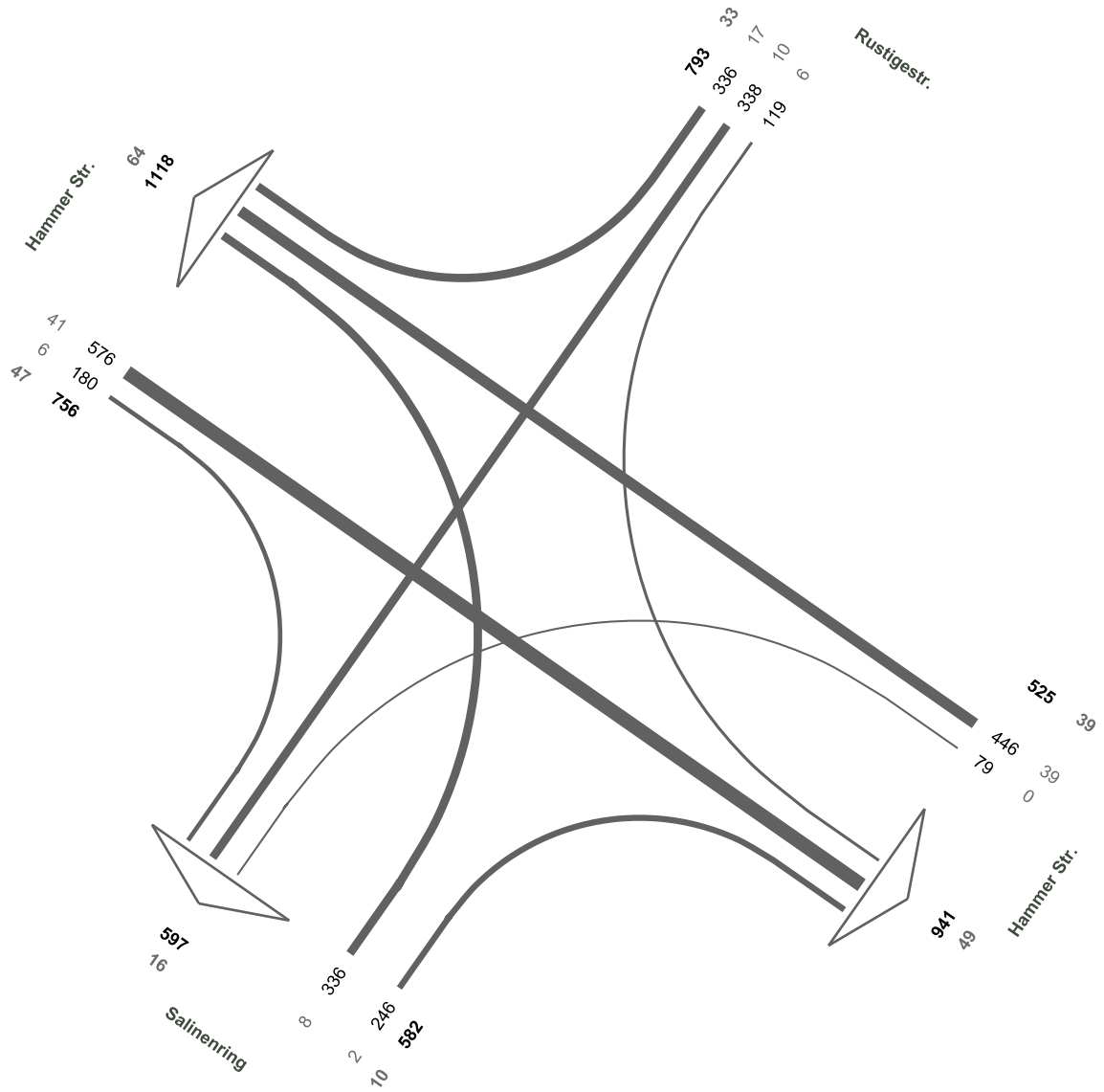

02 - Hammer Str. / Rustigestr. / Salinenring

28.11.2017
16:00 - 17:00 Uhr
Abendspitze
Kfz (SV)

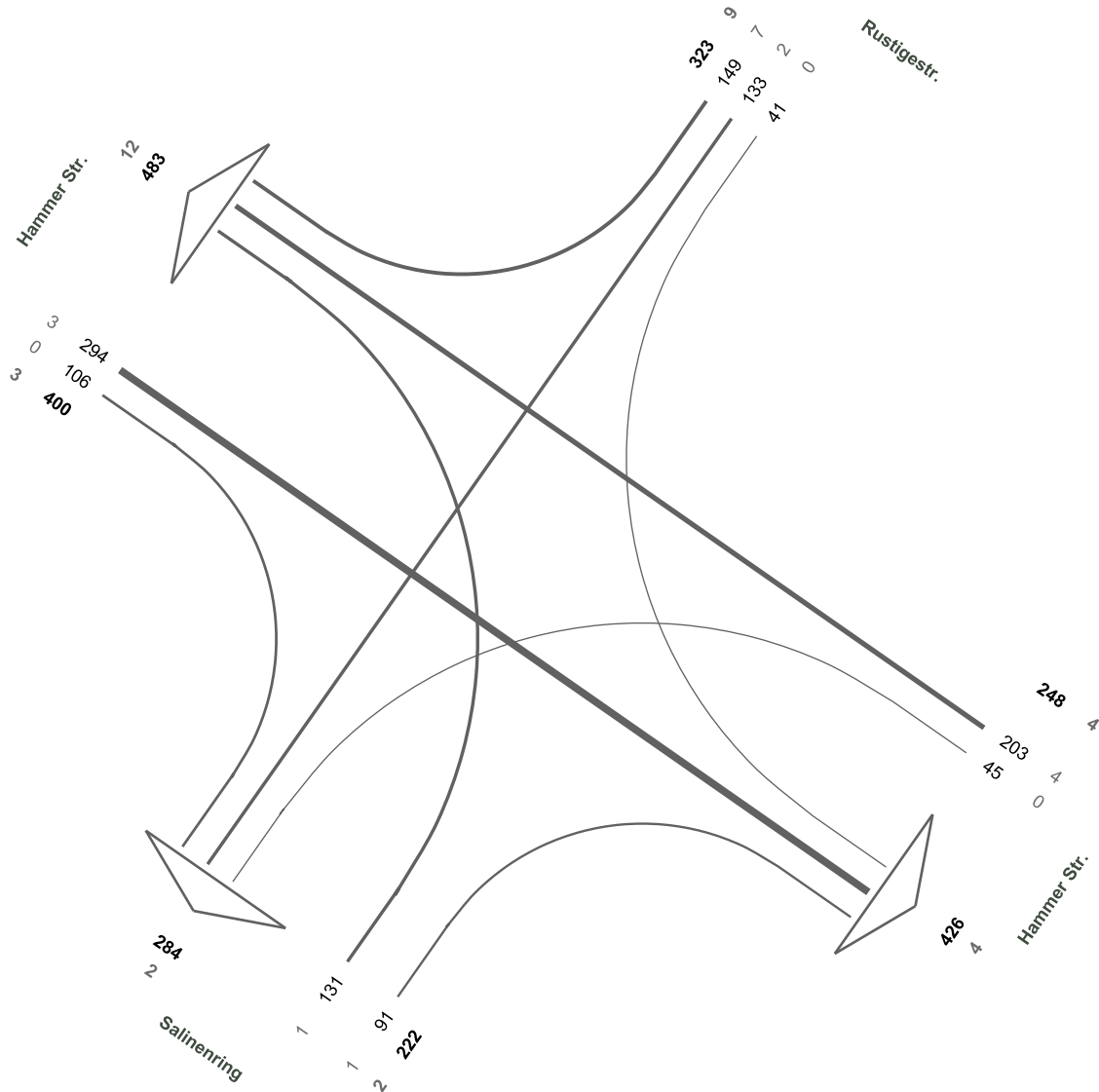

02 - Hammer Str. / Rustigestr. / Salinenring

28.11.2017
15:00 - 19:00 Uhr
4-h-Block
Kfz (SV)

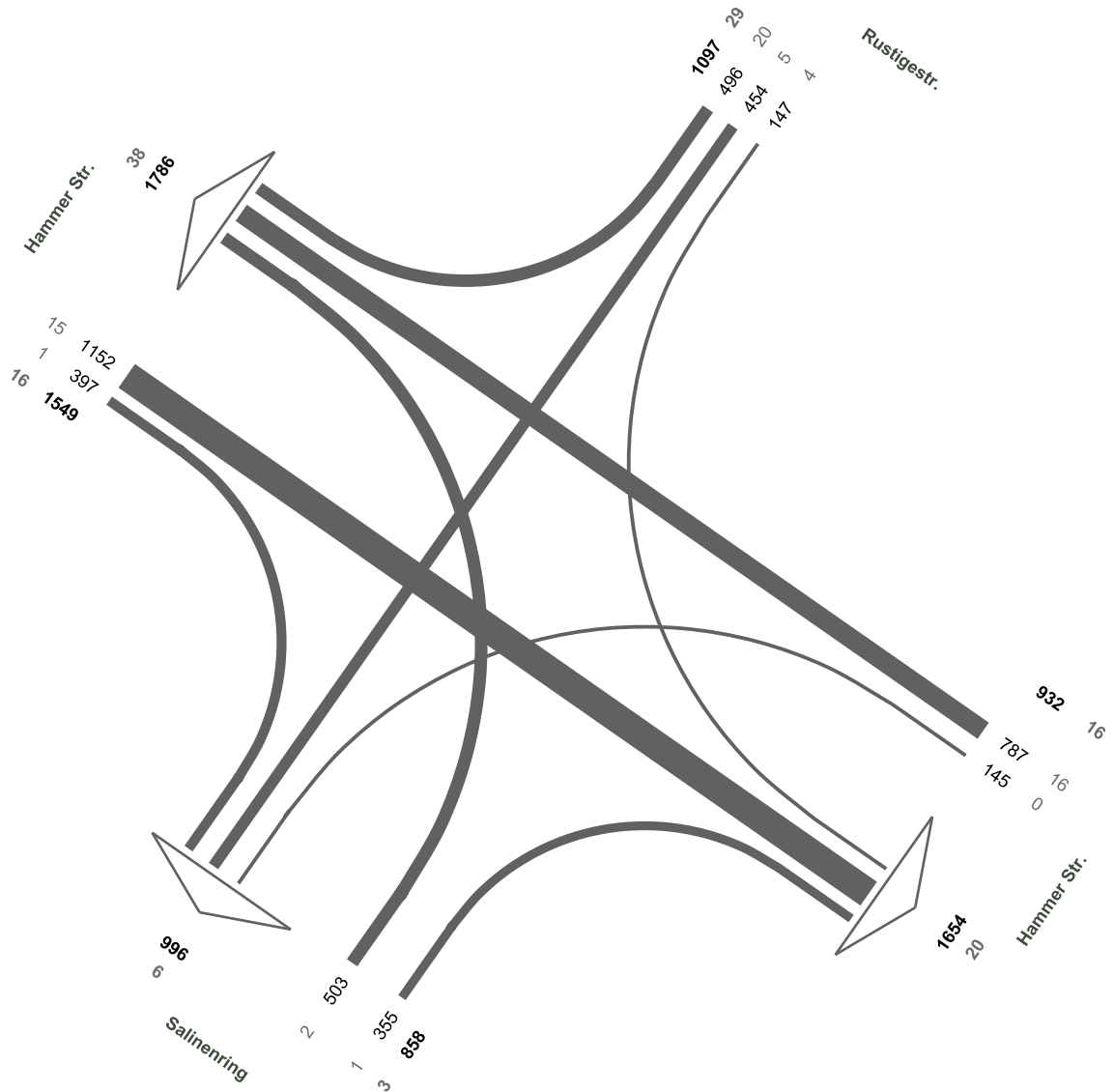

03 - Langenwiedenweg / Brandisstr. / Grafenstr.

28.11.2017
07:15 - 08:15 Uhr
Morgenspitze
Kfz (SV)

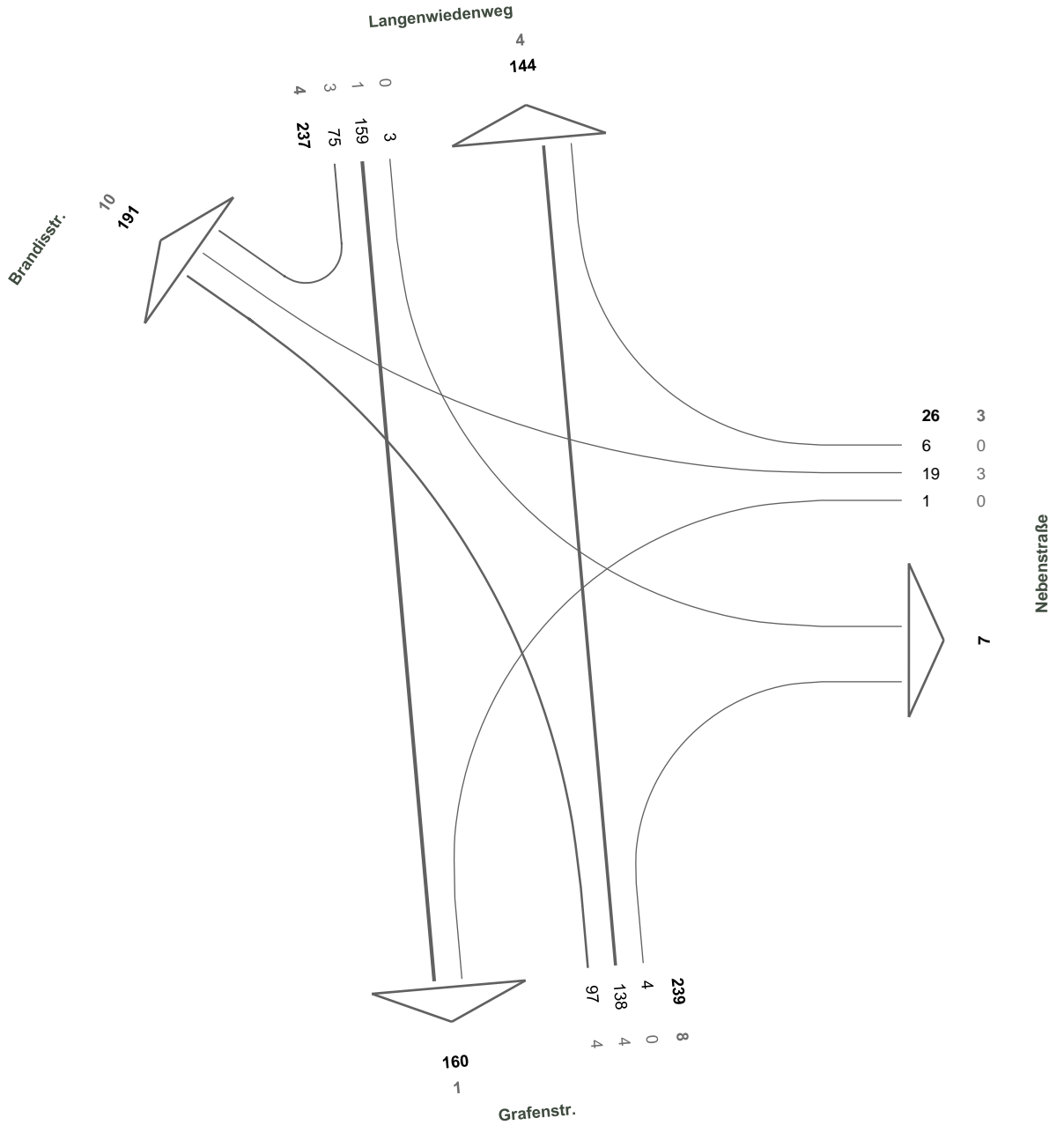

03 - Langenwiedenweg / Brandisstr. / Grafenstr.

28.11.2017
06:00 - 10:00 Uhr
4-h-Block
Kfz (SV)

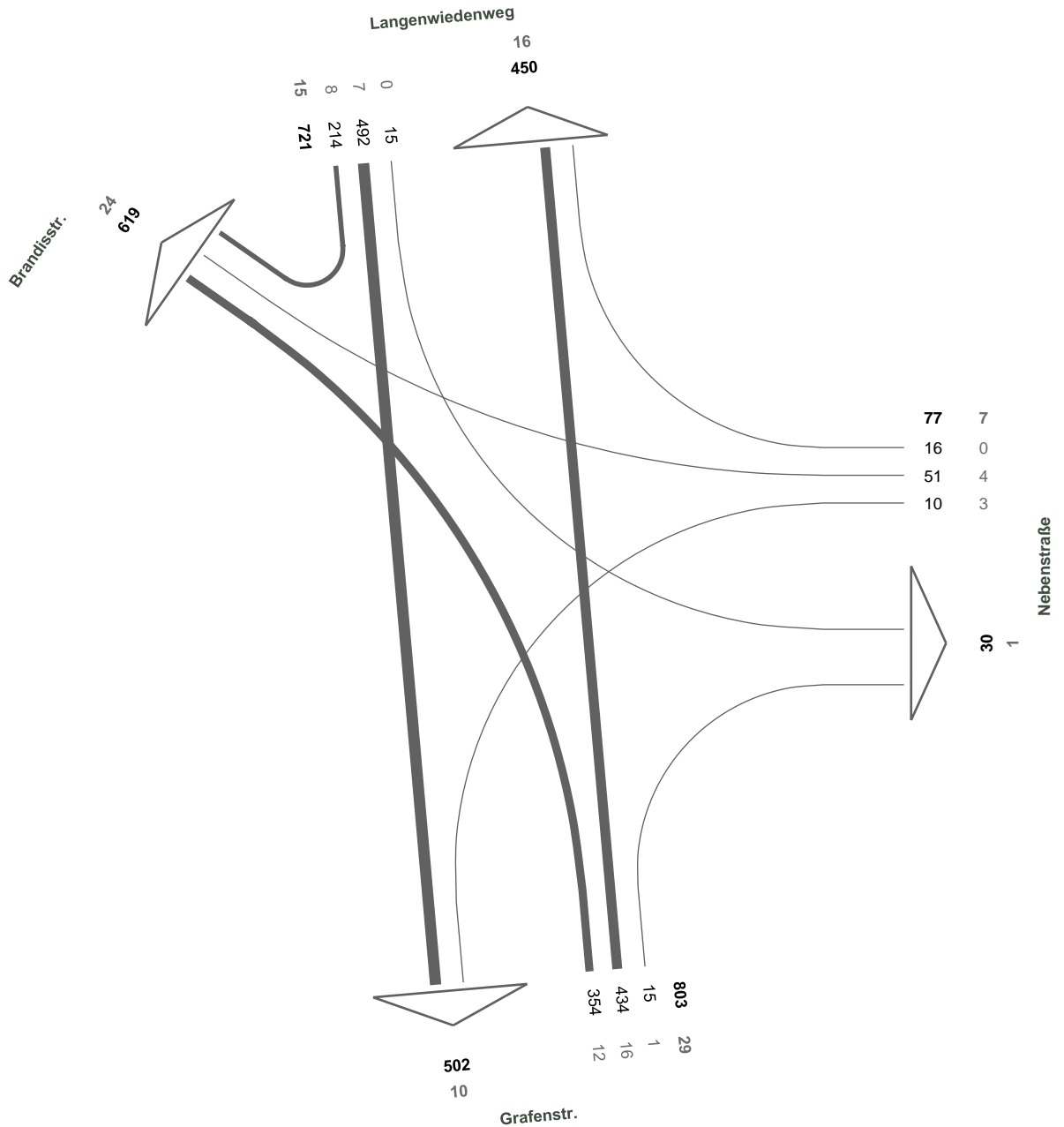

03 - Langenwiedenweg / Brandisstr. / Grafenstr.

28.11.2017
15:45 - 16:45 Uhr
Abendspitze
Kfz (SV)

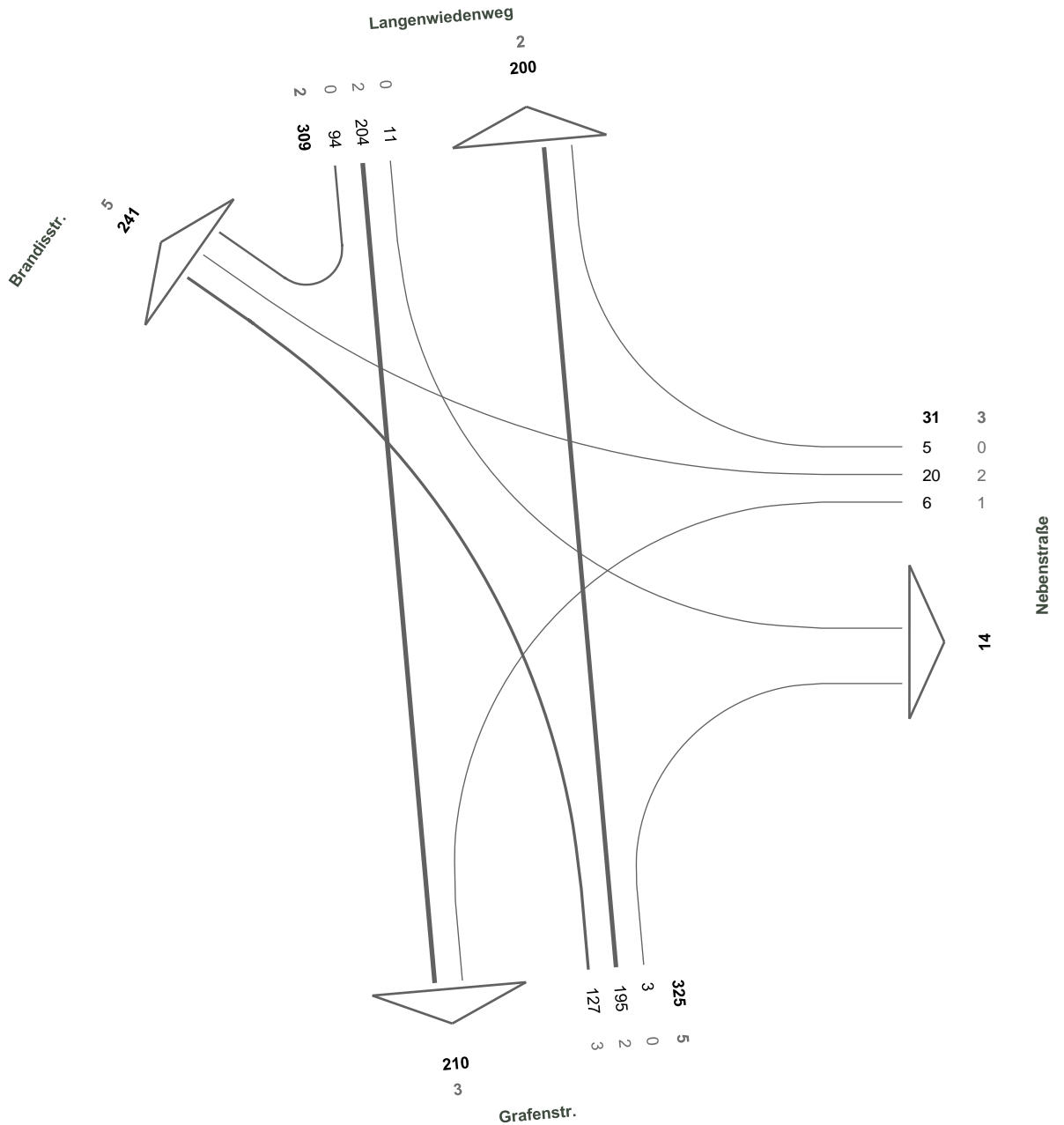

03 - Langenwiedenweg / Brandisstr. / Grafenstr.

28.11.2017
15:00 - 19:00 Uhr
4-h-Block
Kfz (SV)

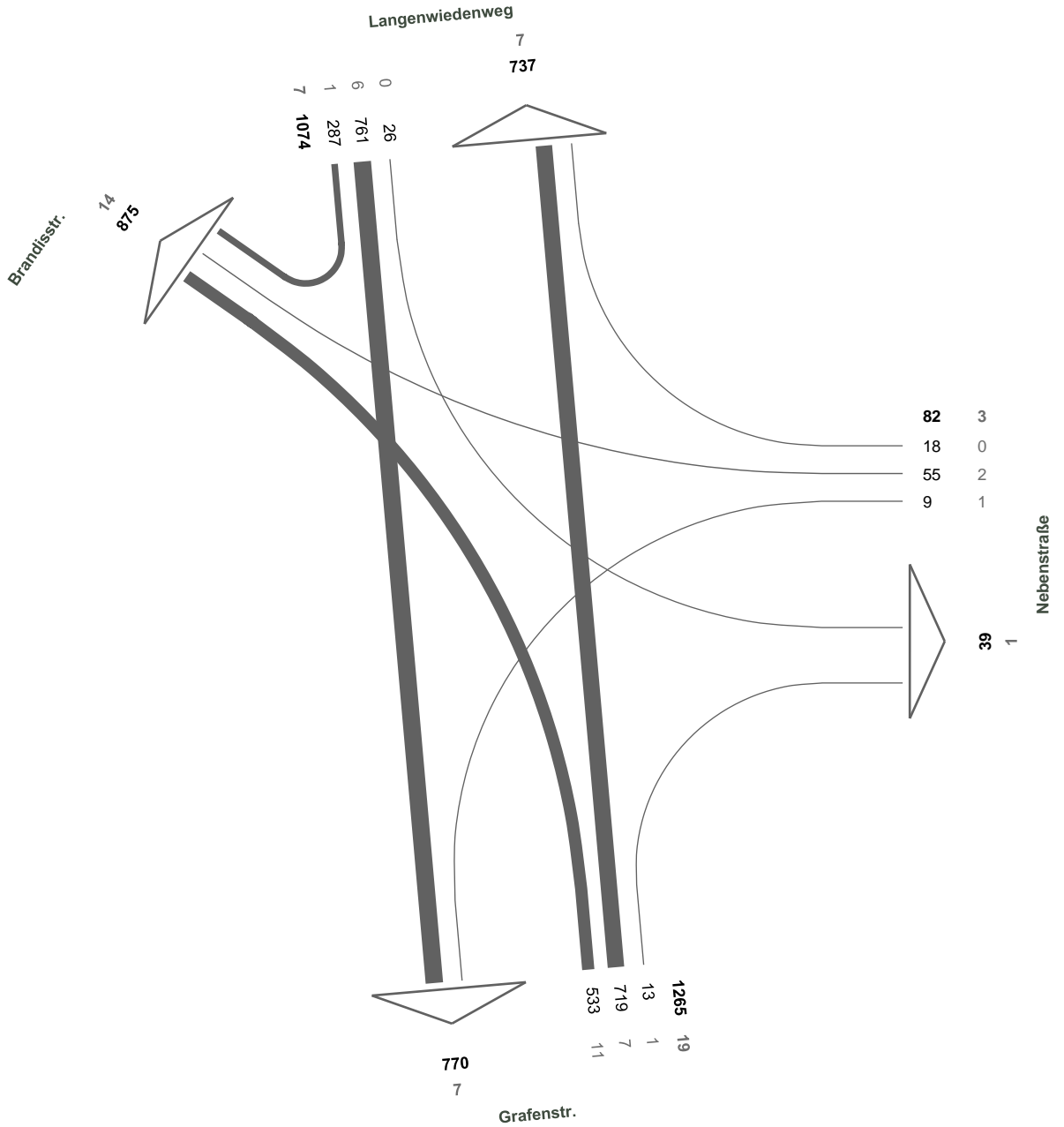

04 - Industriestr. / Am Grüggelgraben

28.11.2017
07:15 - 08:15 Uhr
Morgenspitze
Kfz (SV)

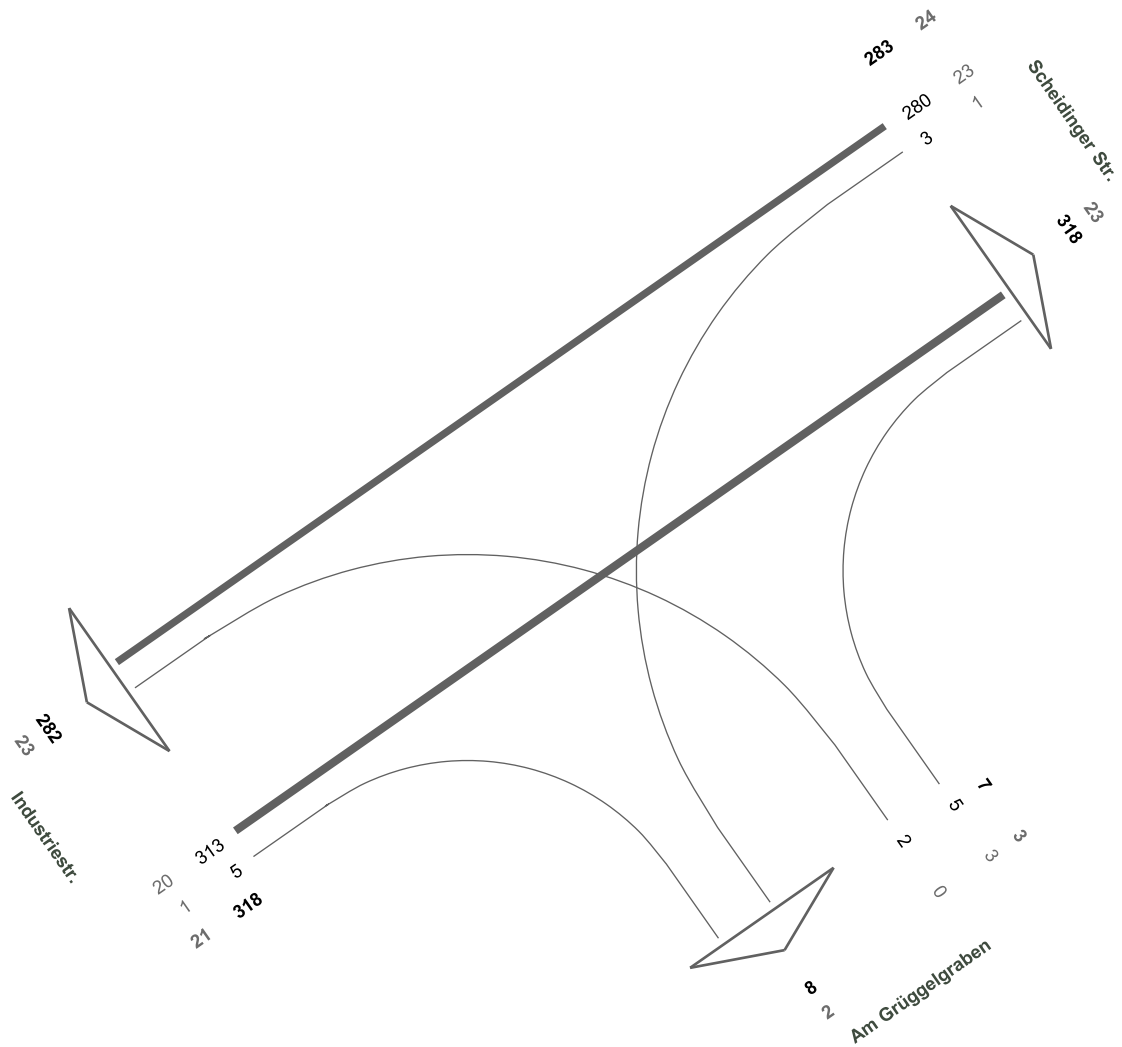

04 - Industriestr. / Am Grüngelgraben

28.11.2017
06:00 - 10:00 Uhr
4-h-Block
Kfz (SV)

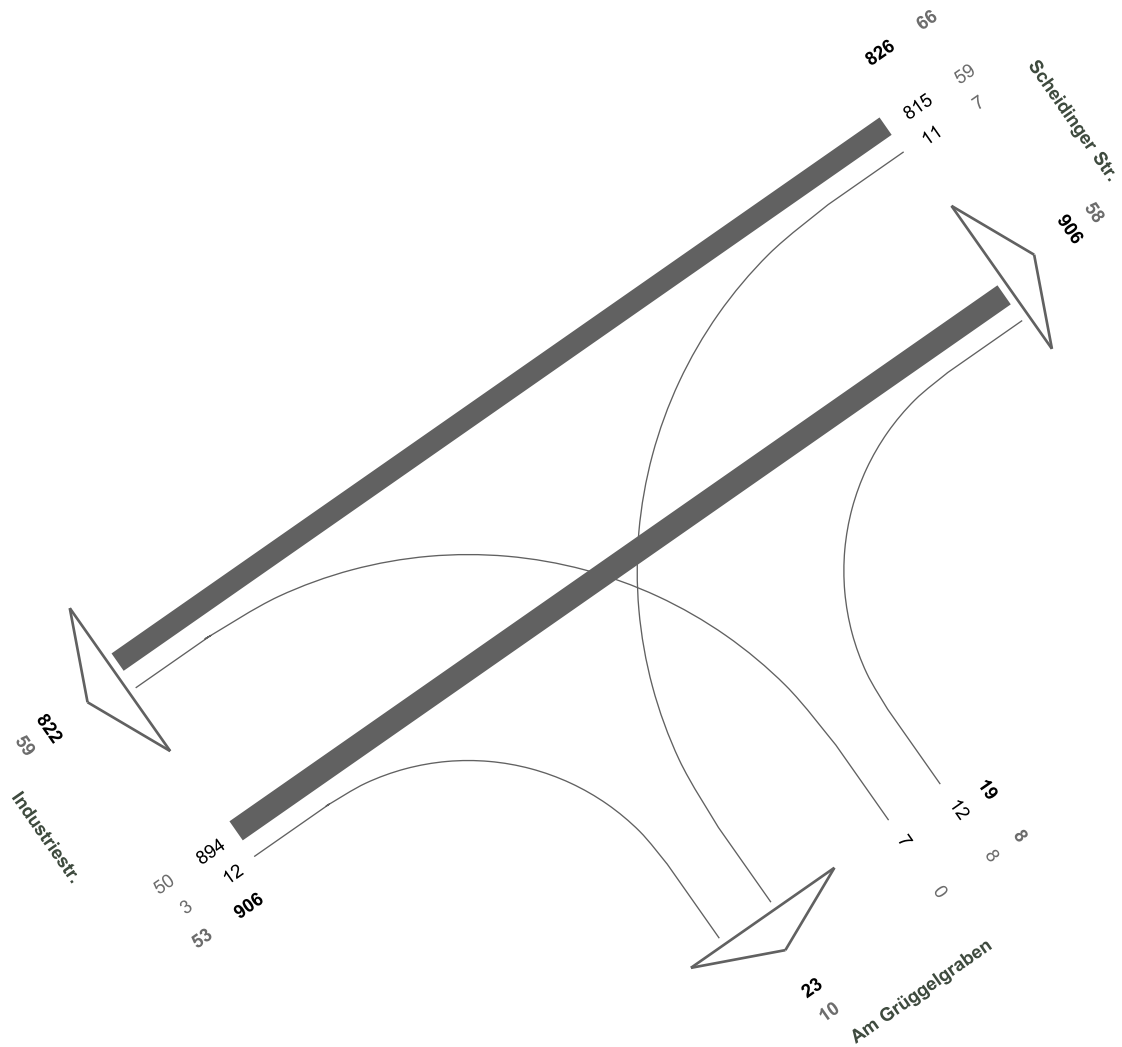

04 - Industriestr. / Am Grüggelgraben

28.11.2017
15:30 - 16:30 Uhr
Abendspitze
Kfz (SV)

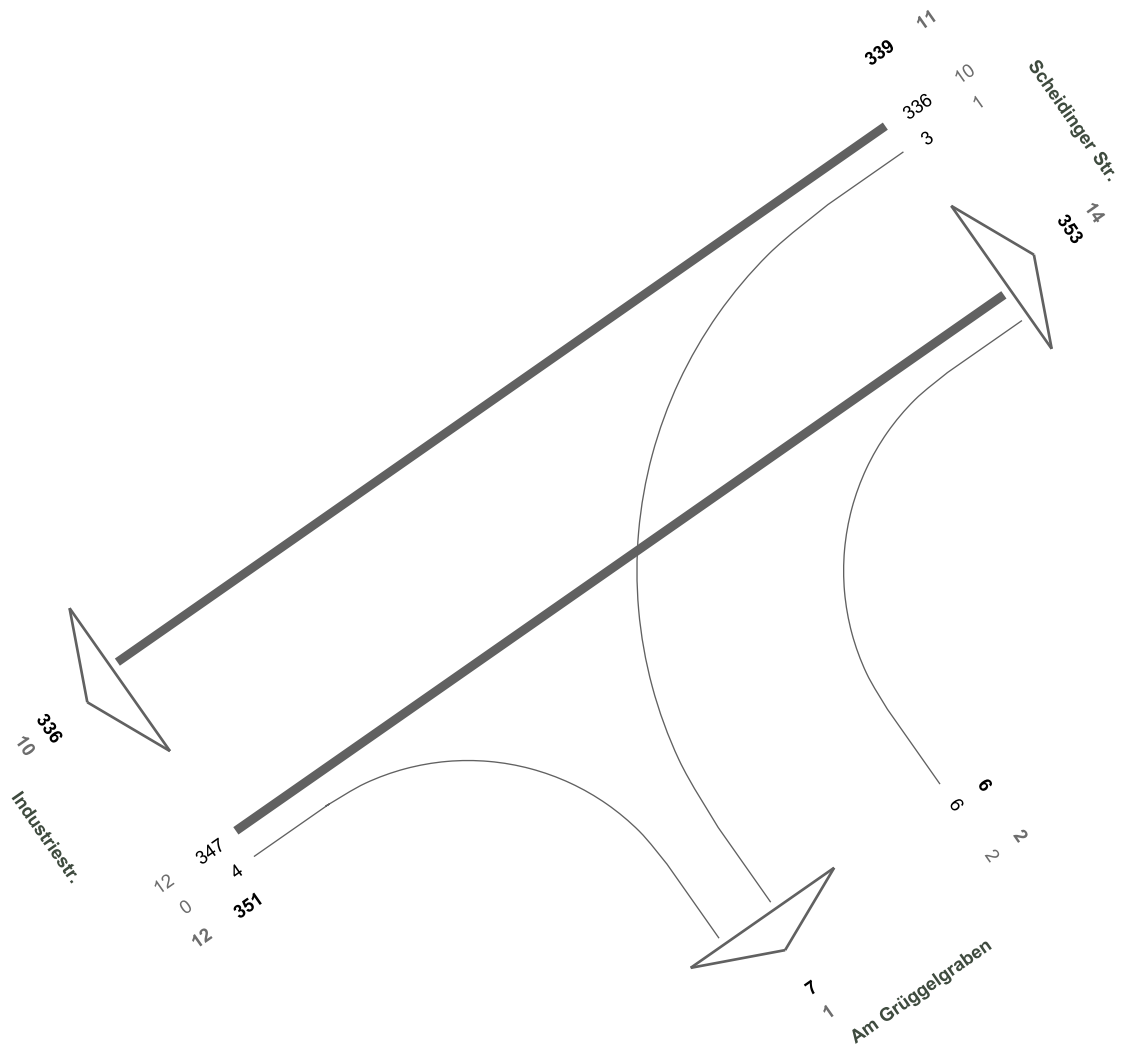

04 - Industriestr. / Am Grüggelgraben

28.11.2017
15:00 - 19:00 Uhr
4-h-Block
Kfz (SV)

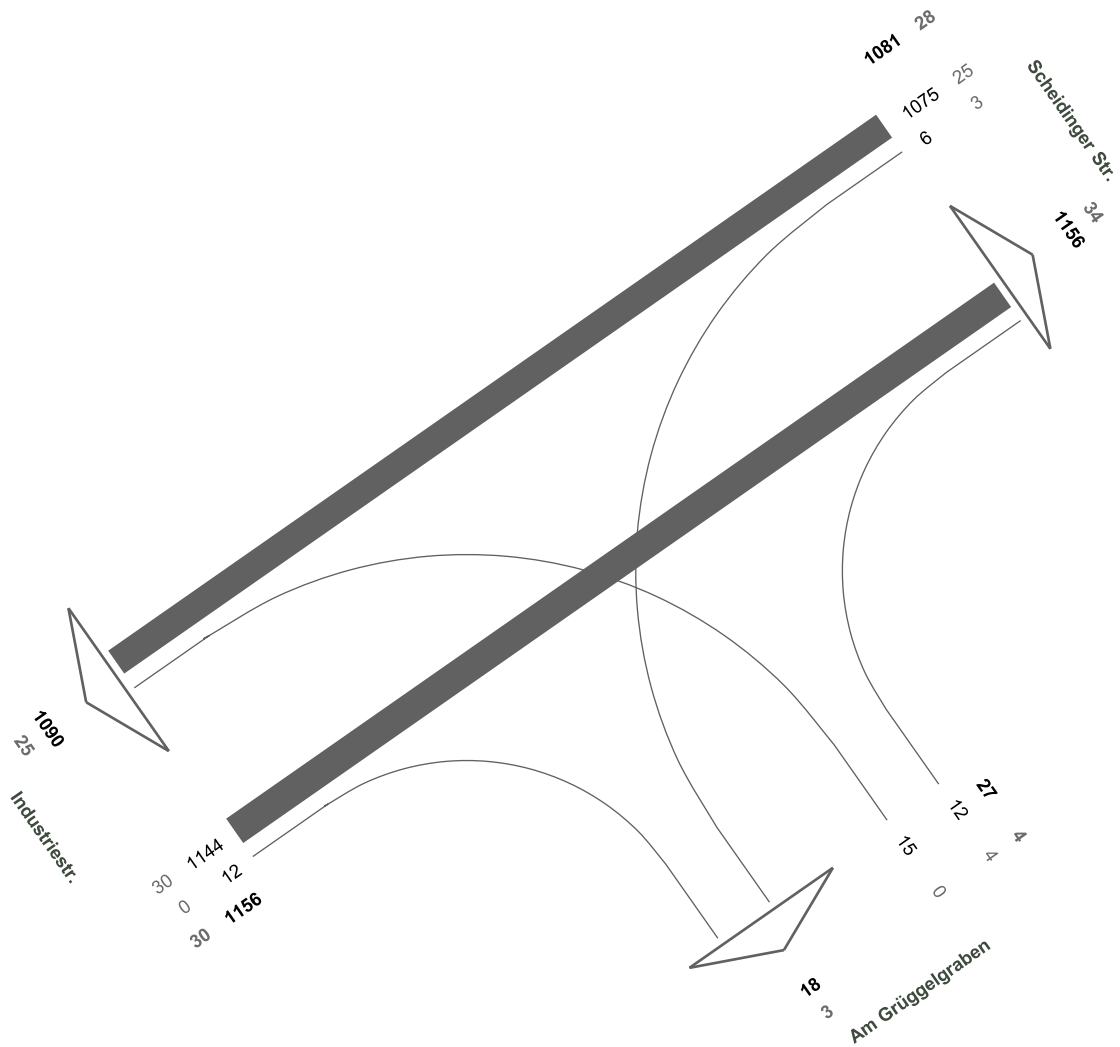

05 - Industriestr. / Bergstraßer Weg / Scheidinger Str.

28.11.2017
07:15 - 08:15 Uhr
Morgenspitze
Kfz (SV)

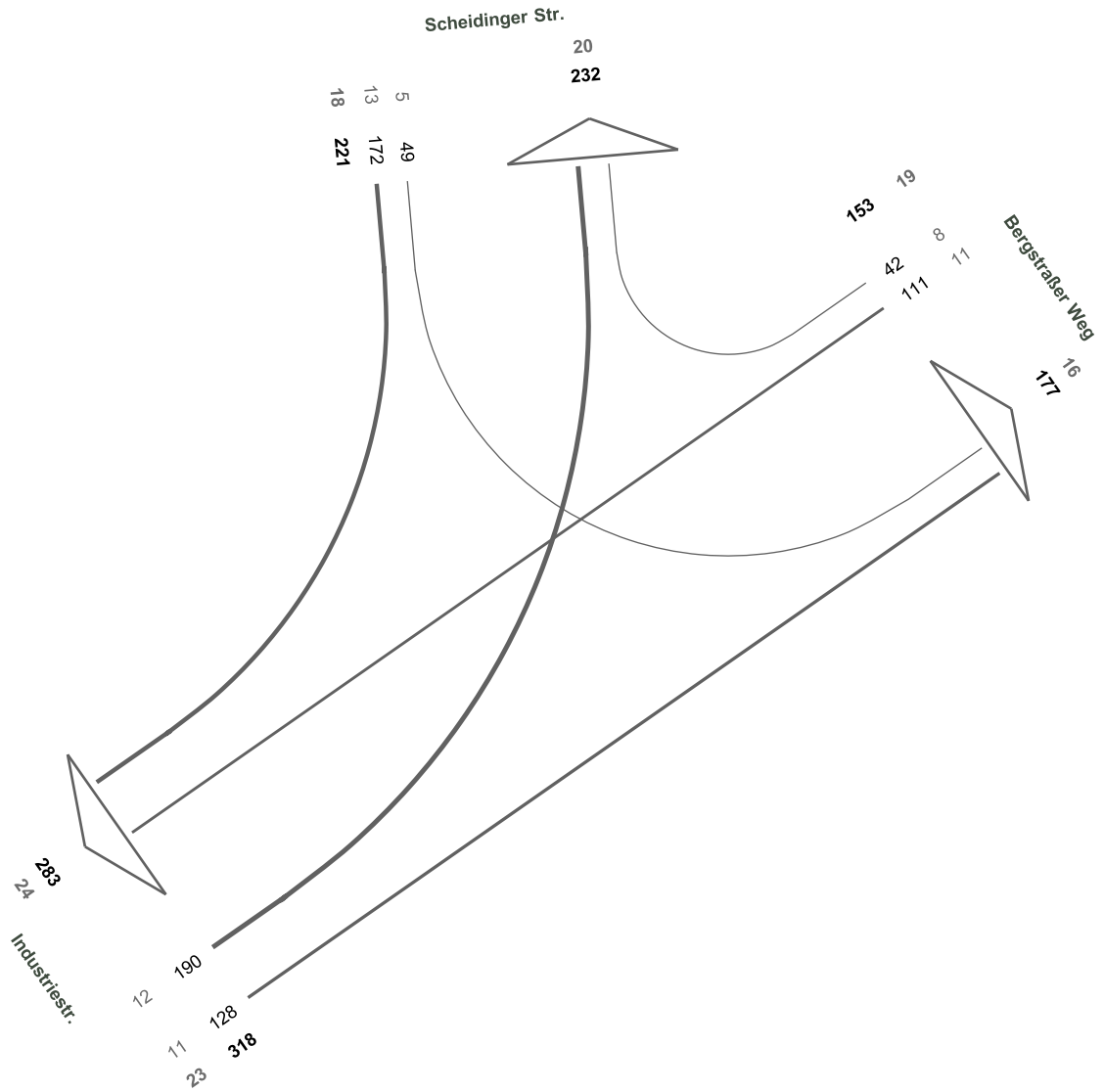

05 - Industriestr. / Bergstraßer Weg / Scheidinger Str.

28.11.2017
06:00 - 10:00 Uhr
4-h-Block
Kfz (SV)

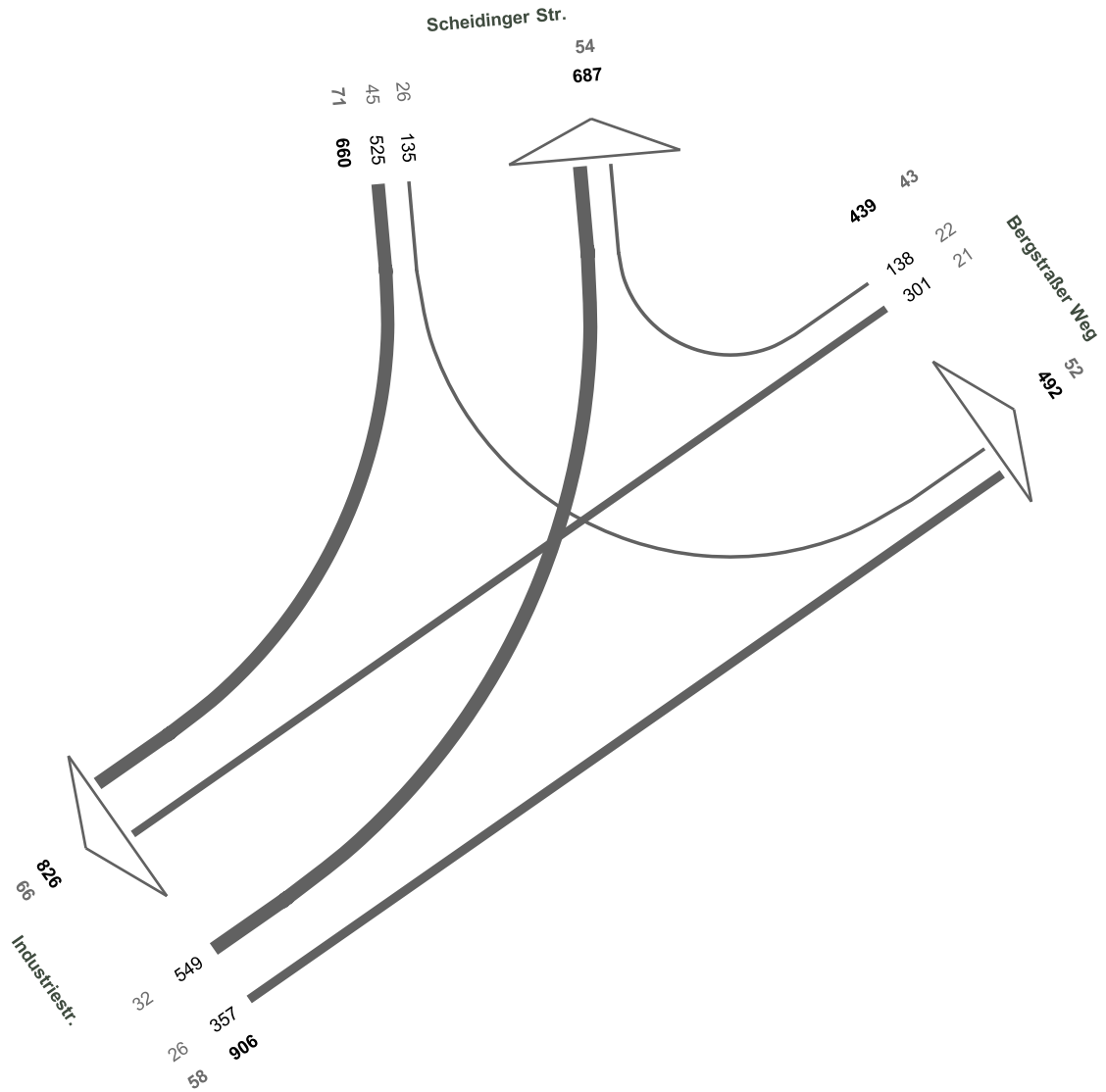

05 - Industriestr. / Bergstraßer Weg / Scheidinger Str.

28.11.2017
15:00 - 16:00 Uhr
Abendspitze
Kfz (SV)

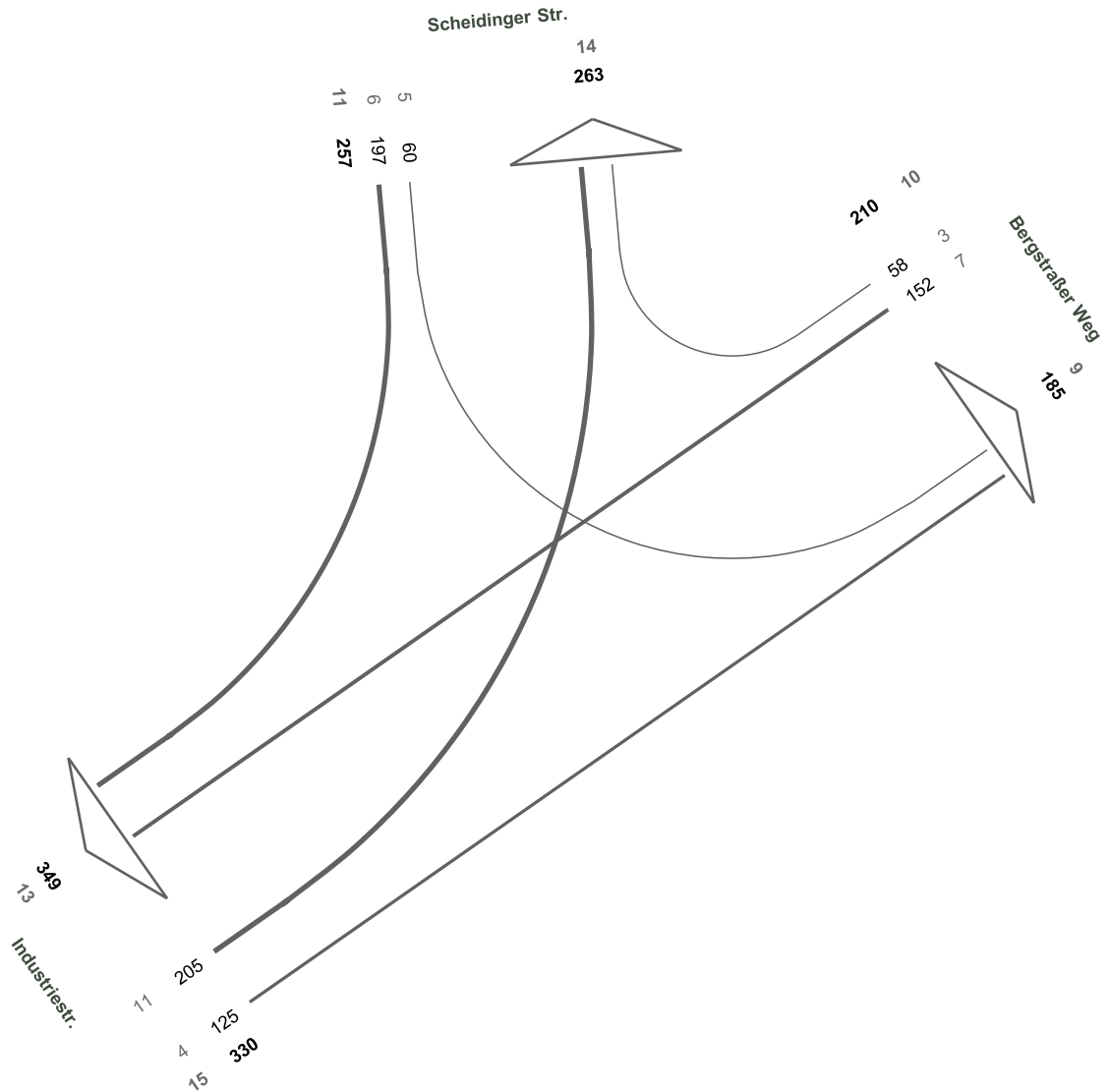

05 - Industriestr. / Bergstraßer Weg / Scheidinger Str.

28.11.2017
15:00 - 19:00 Uhr
4-h-Block
Kfz (SV)

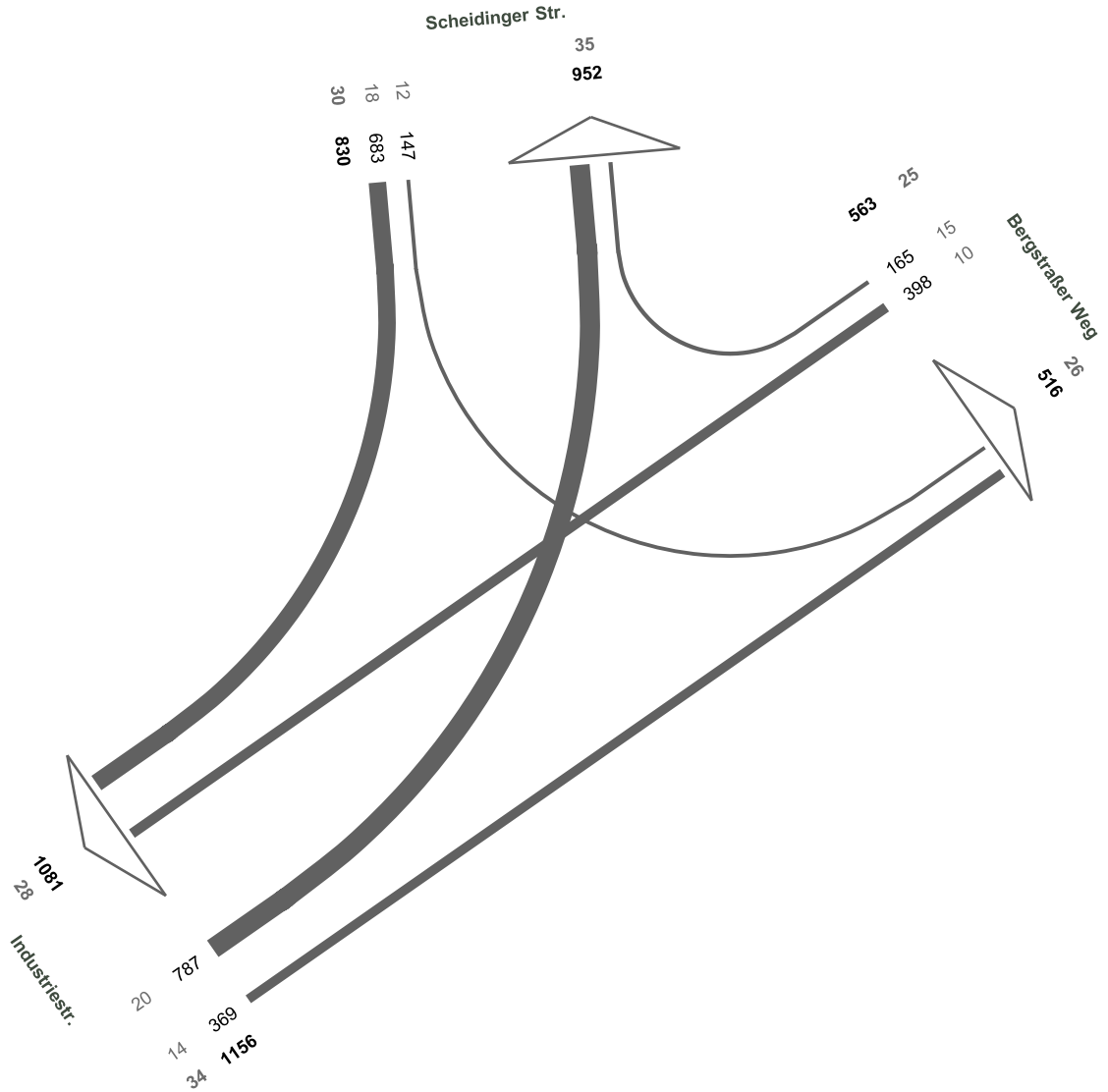

06 - Scheidinger Str. / Hansering

28.11.2017
07:00 - 08:00 Uhr
Morgenspitze
Kfz (SV)

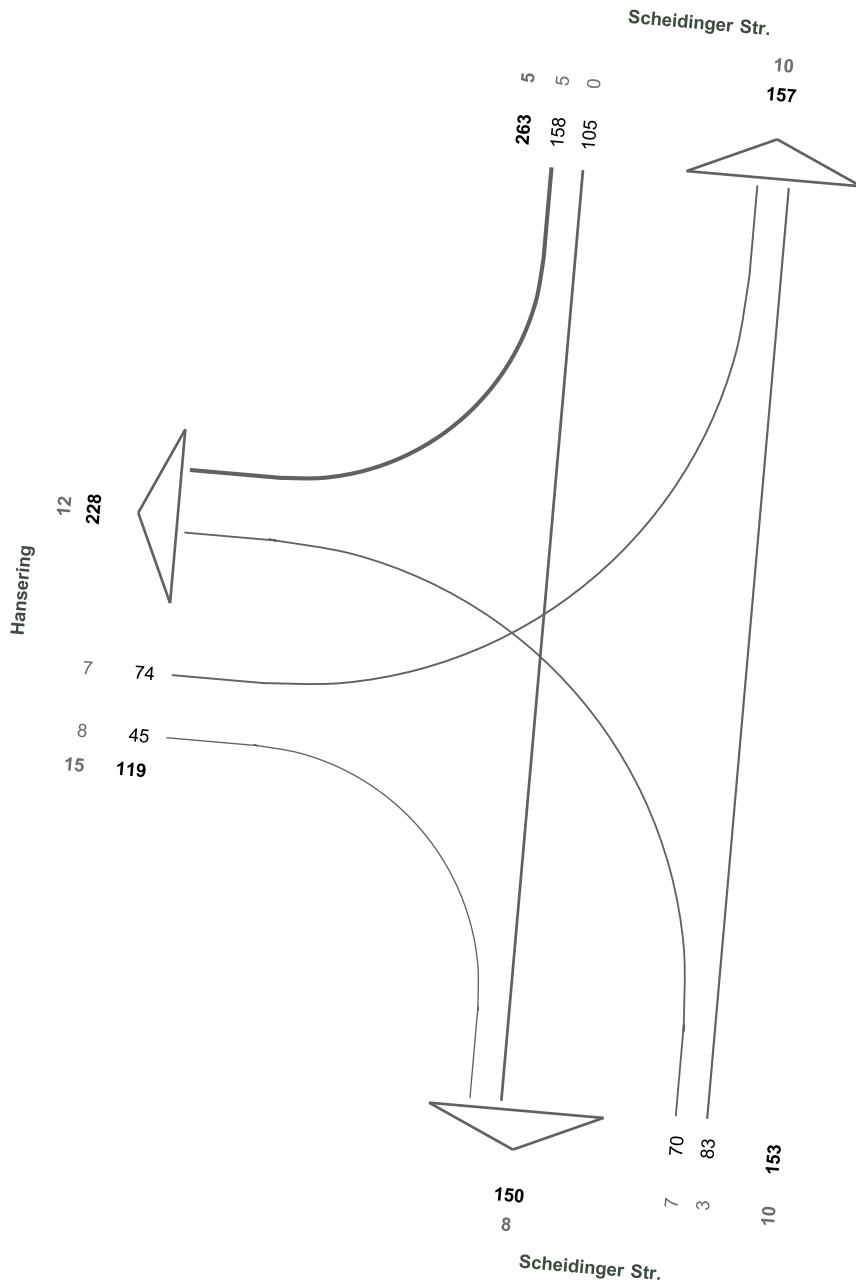

06 - Scheidinger Str. / Hansering

28.11.2017
06:00 - 10:00 Uhr
4-h-Block
Kfz (SV)

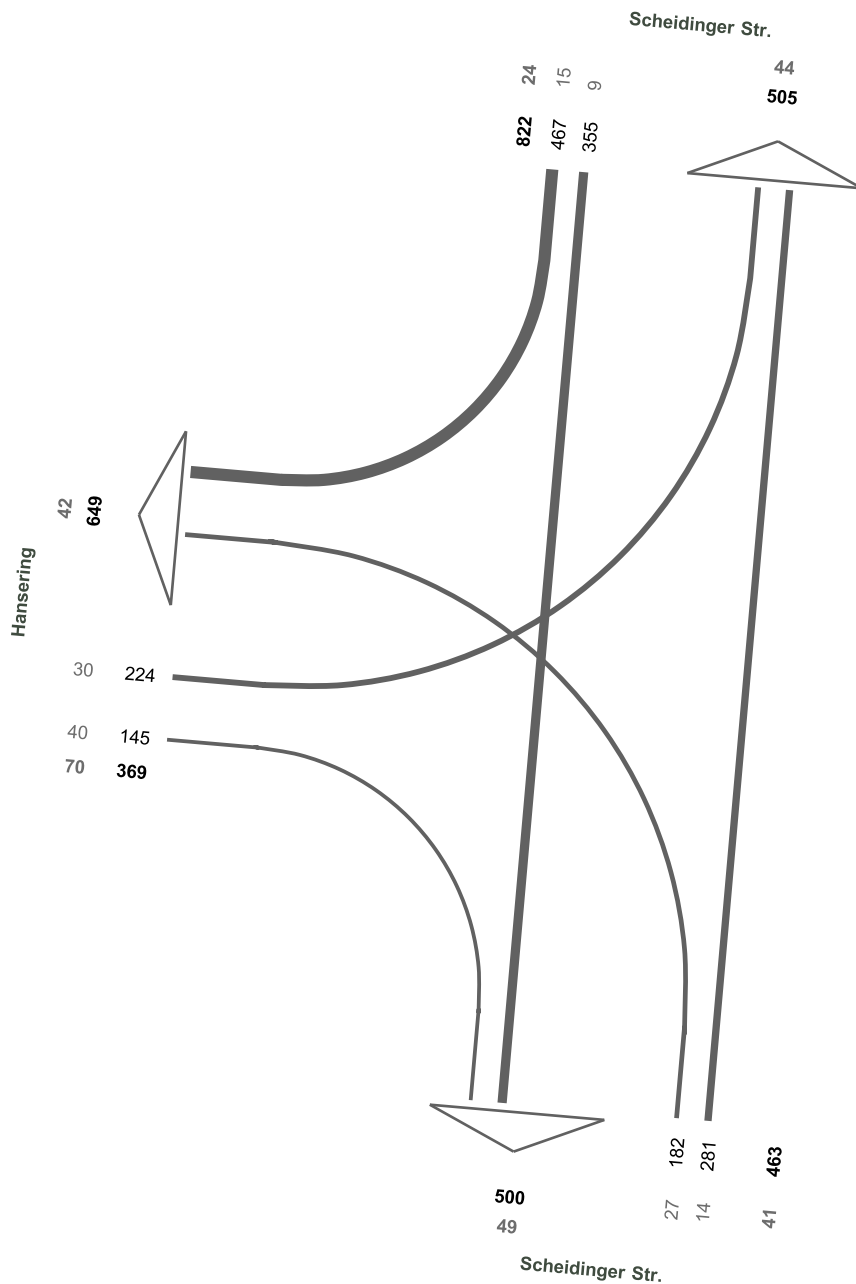

06 - Scheidinger Str. / Hansering

28.11.2017
16:30 - 17:30 Uhr
Abendspitze
Kfz (SV)

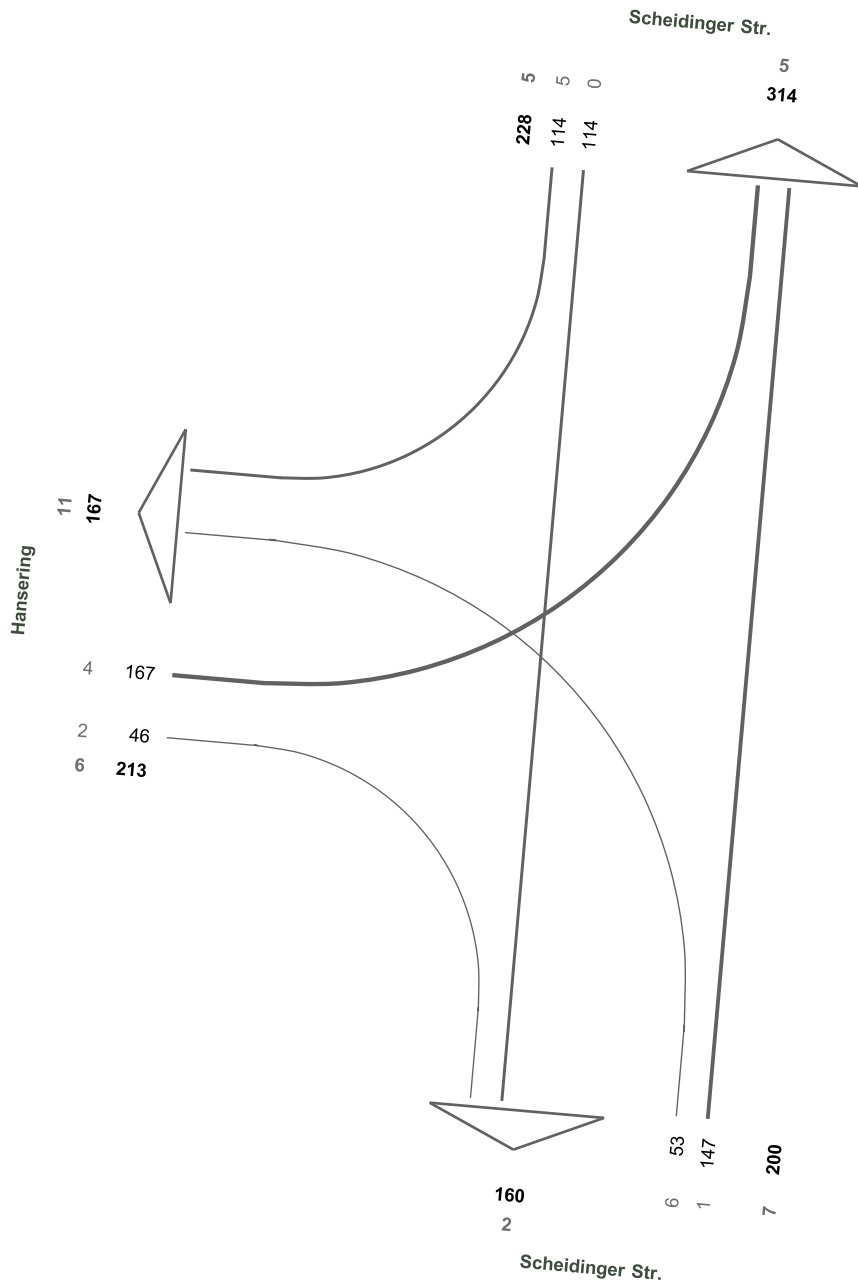

06 - Scheidinger Str. / Hansering

28.11.2017
15:00 - 19:00 Uhr
4-h-Block
Kfz (SV)

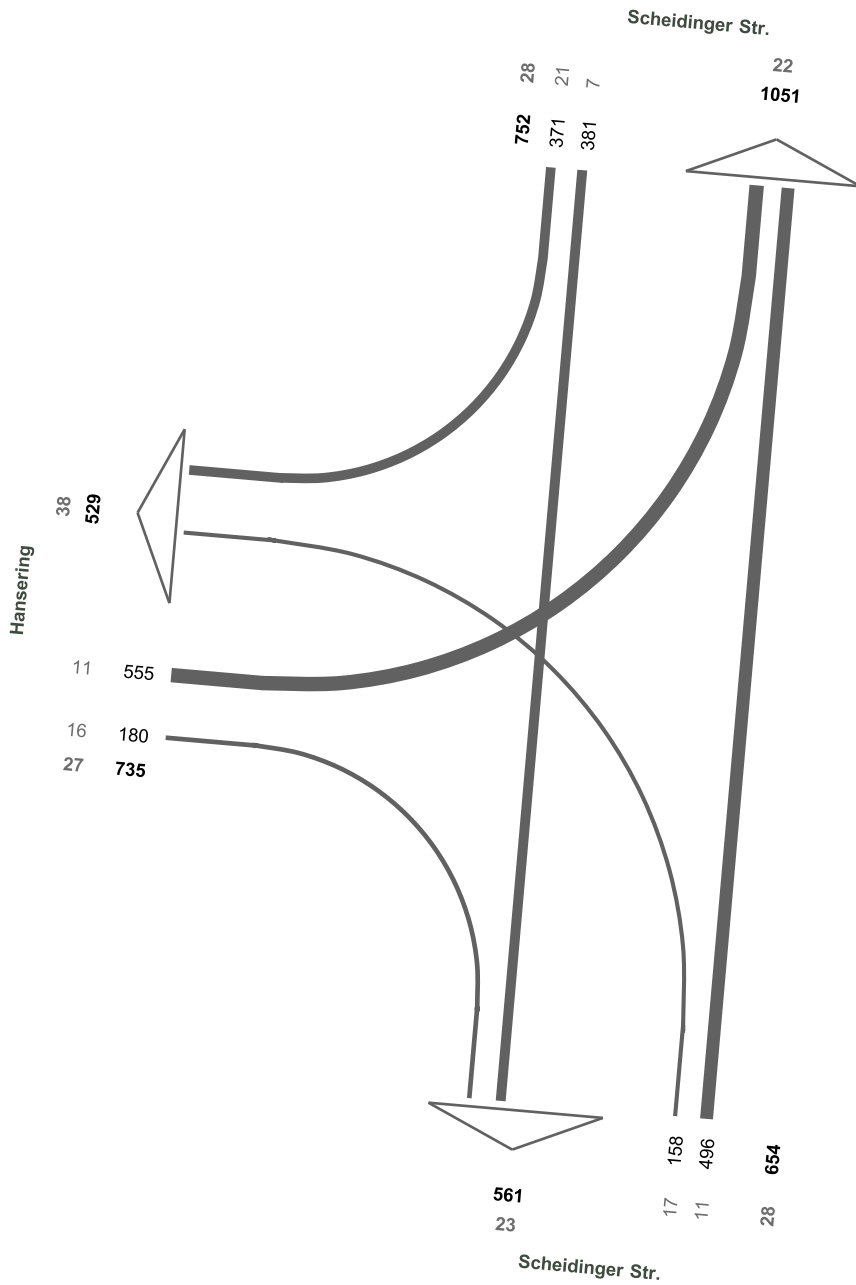

07 - Grafenstr. / Bahnhofstr.

28.11.2017
07:15 - 08:15 Uhr
Morgenspitze
Kfz (SV)

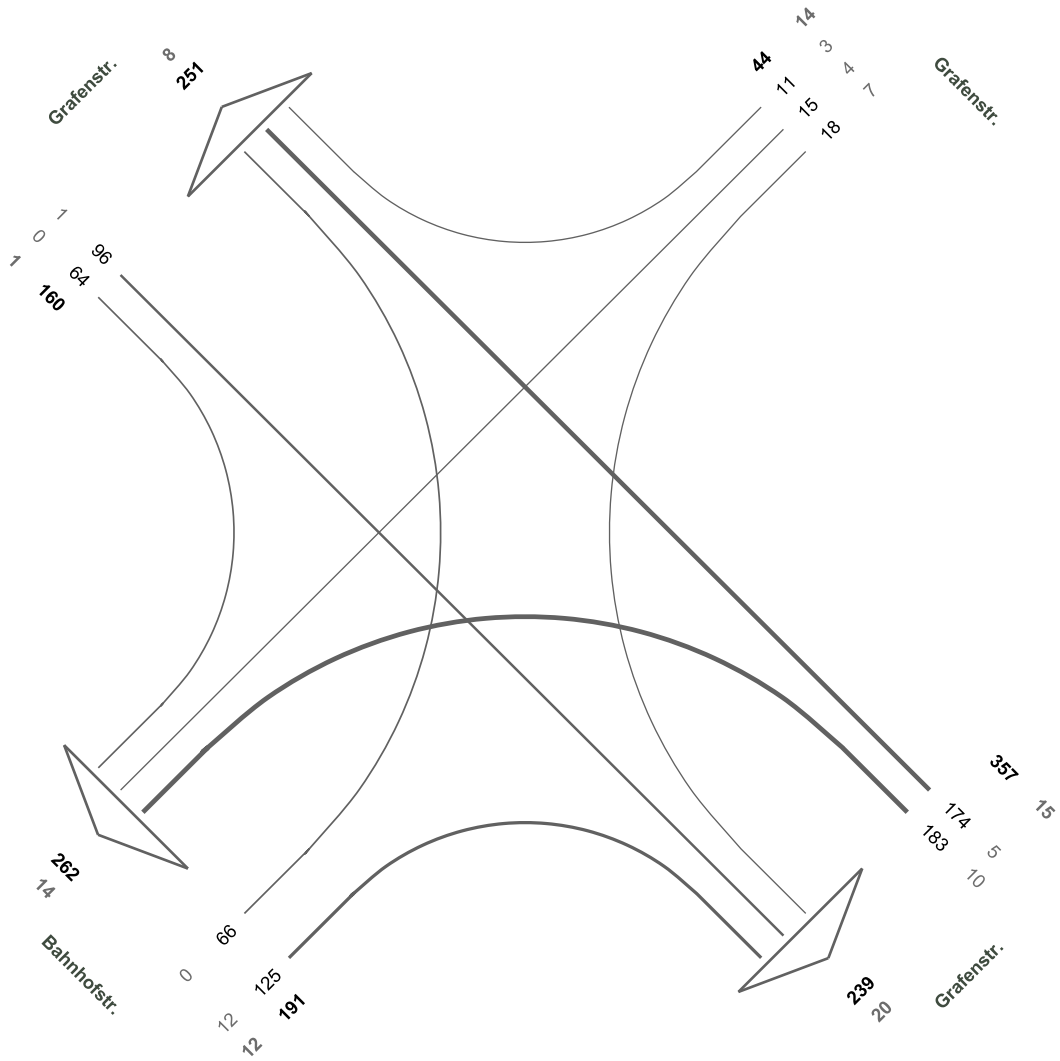

07 - Grafenstr. / Bahnhofstr.

28.11.2017
06:00 - 10:00 Uhr
4-h-Block
Kfz (SV)

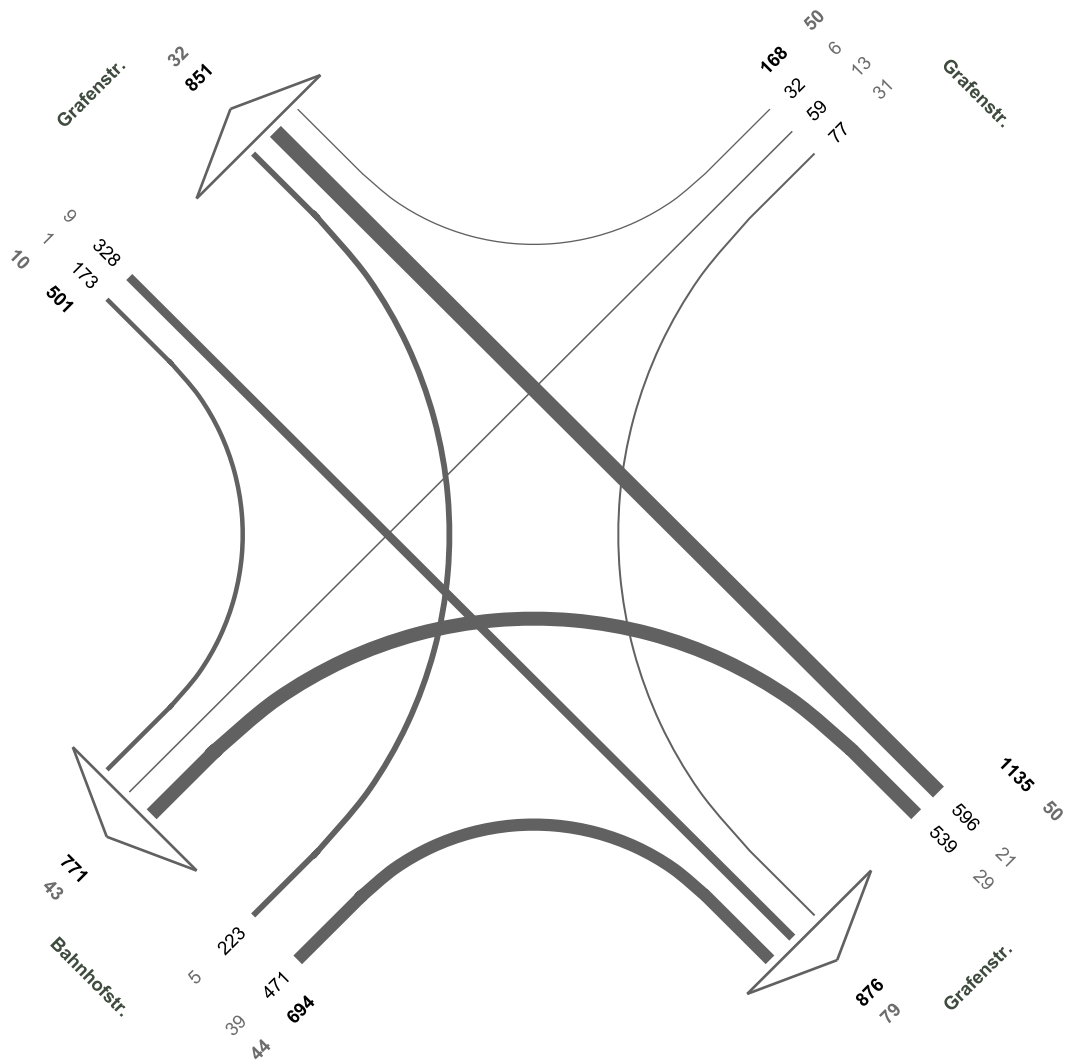

07 - Grafenstr. / Bahnhofstr.

28.11.2017
16:45 - 17:45 Uhr
Abendspitze
Kfz (SV)

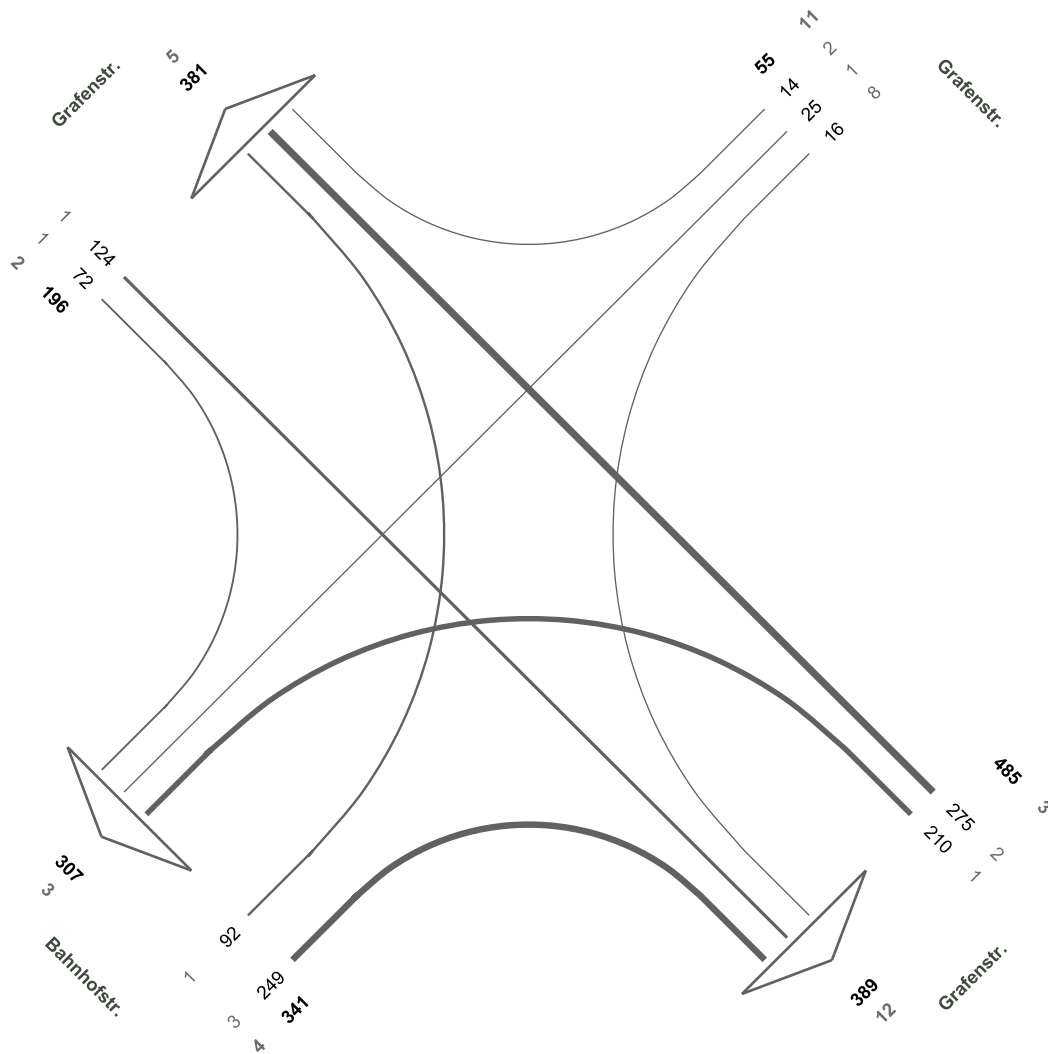

07 - Grafenstr. / Bahnhofstr.

28.11.2017
15:00 - 19:00 Uhr
4-h-Block
Kfz (SV)

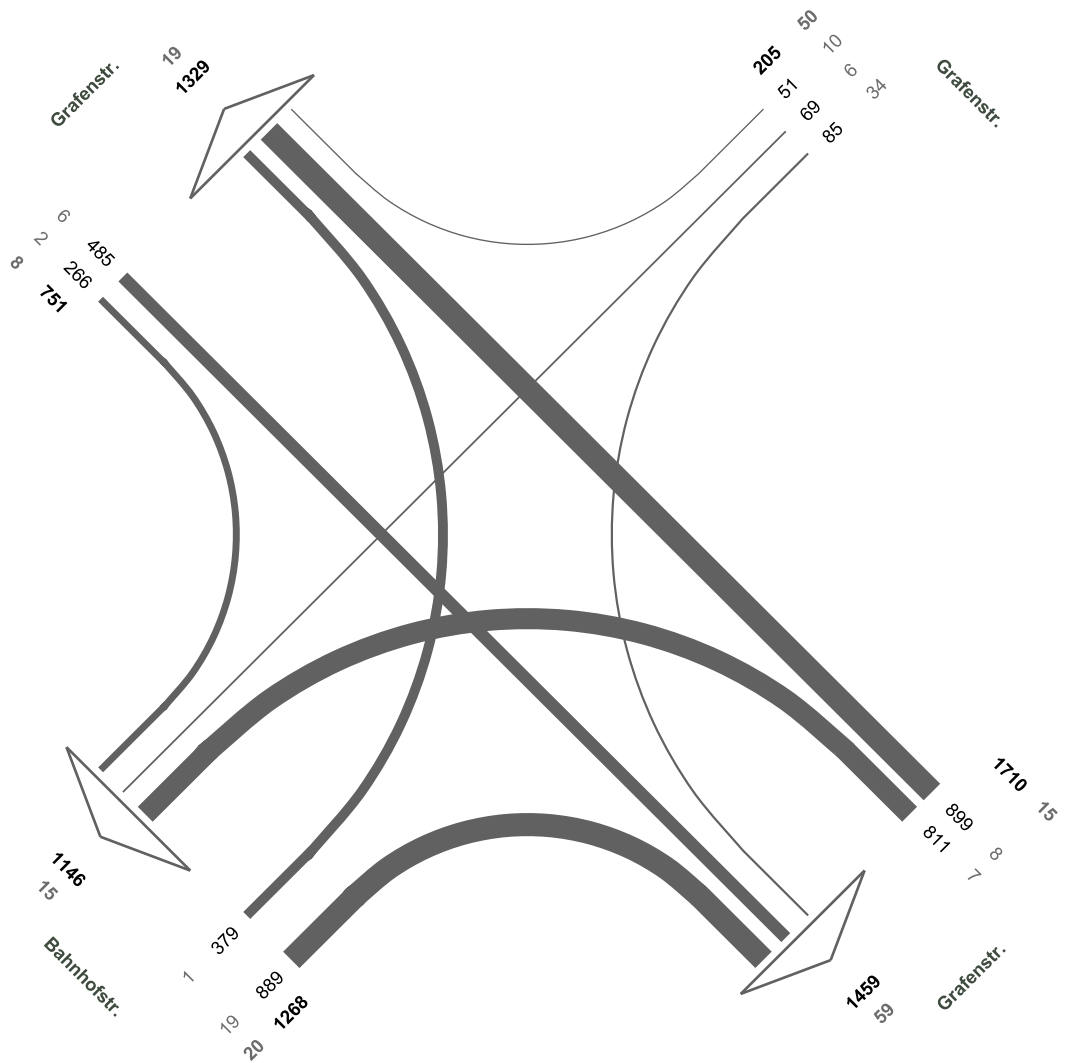

08 - Bahnhofstr. / Hammer Str. / Siederstr.

28.11.2017
07:15 - 08:15 Uhr
Morgenspitze
Kfz (SV)

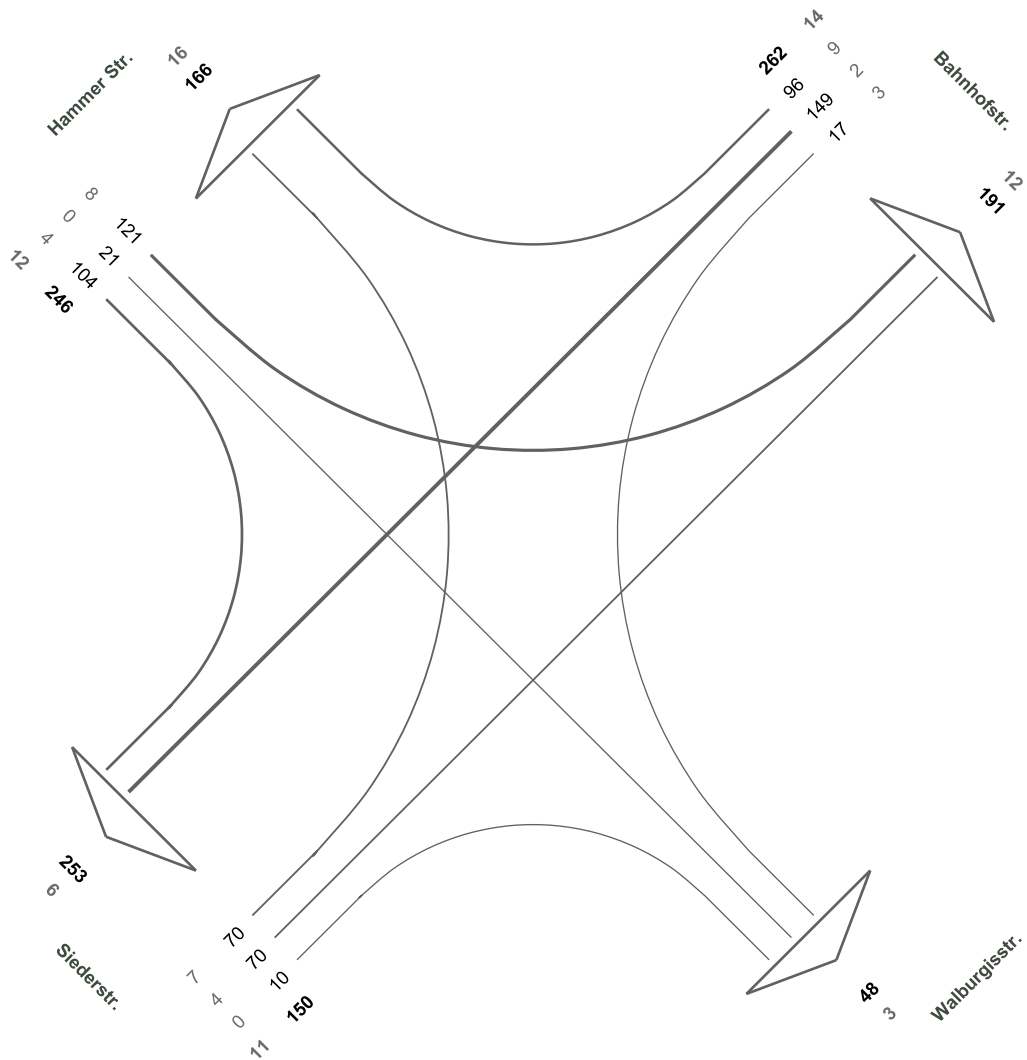

08 - Bahnhofstr. / Hammer Str. / Siederstr.

28.11.2017
06:00 - 10:00 Uhr
4-h-Block
Kfz (SV)

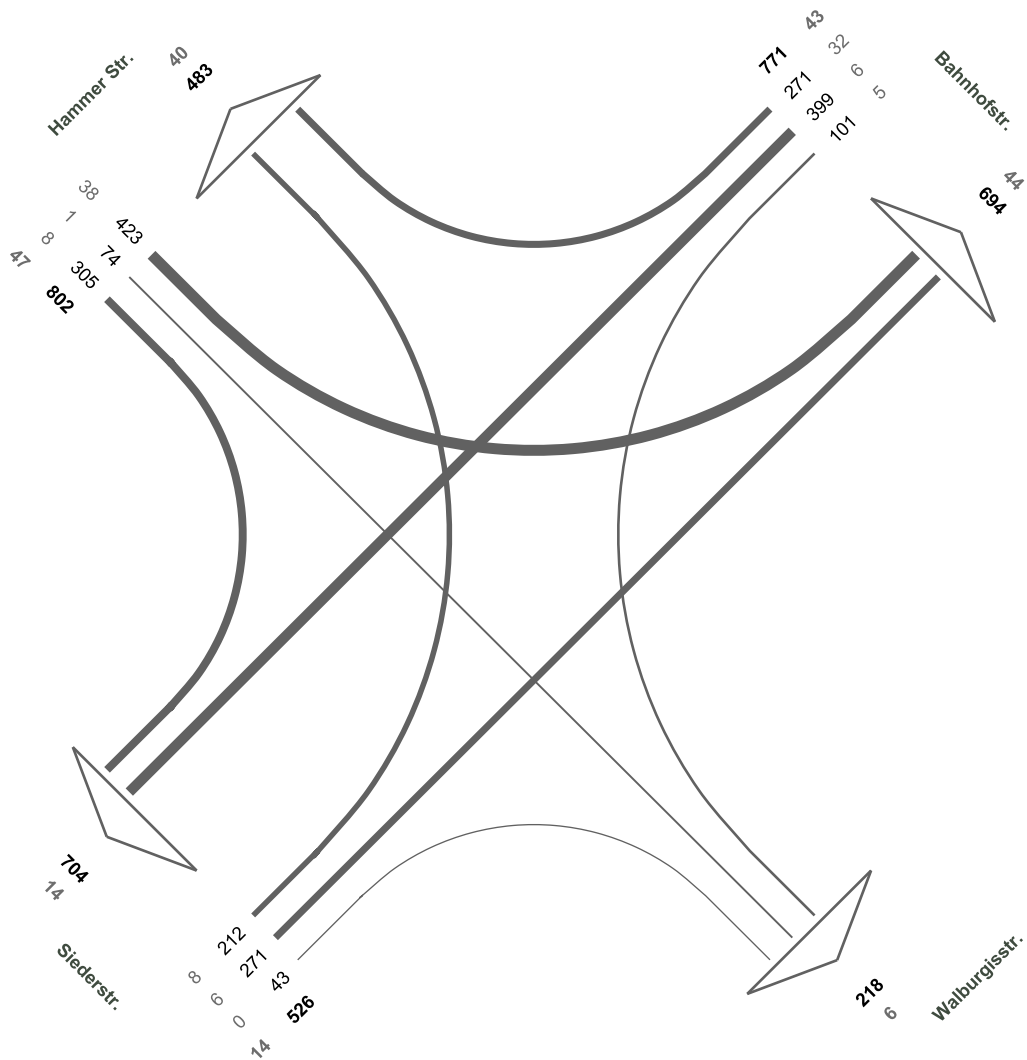

08 - Bahnhofstr. / Hammer Str. / Siederstr.

28.11.2017
16:45 - 17:45 Uhr
Abendspitze
Kfz (SV)

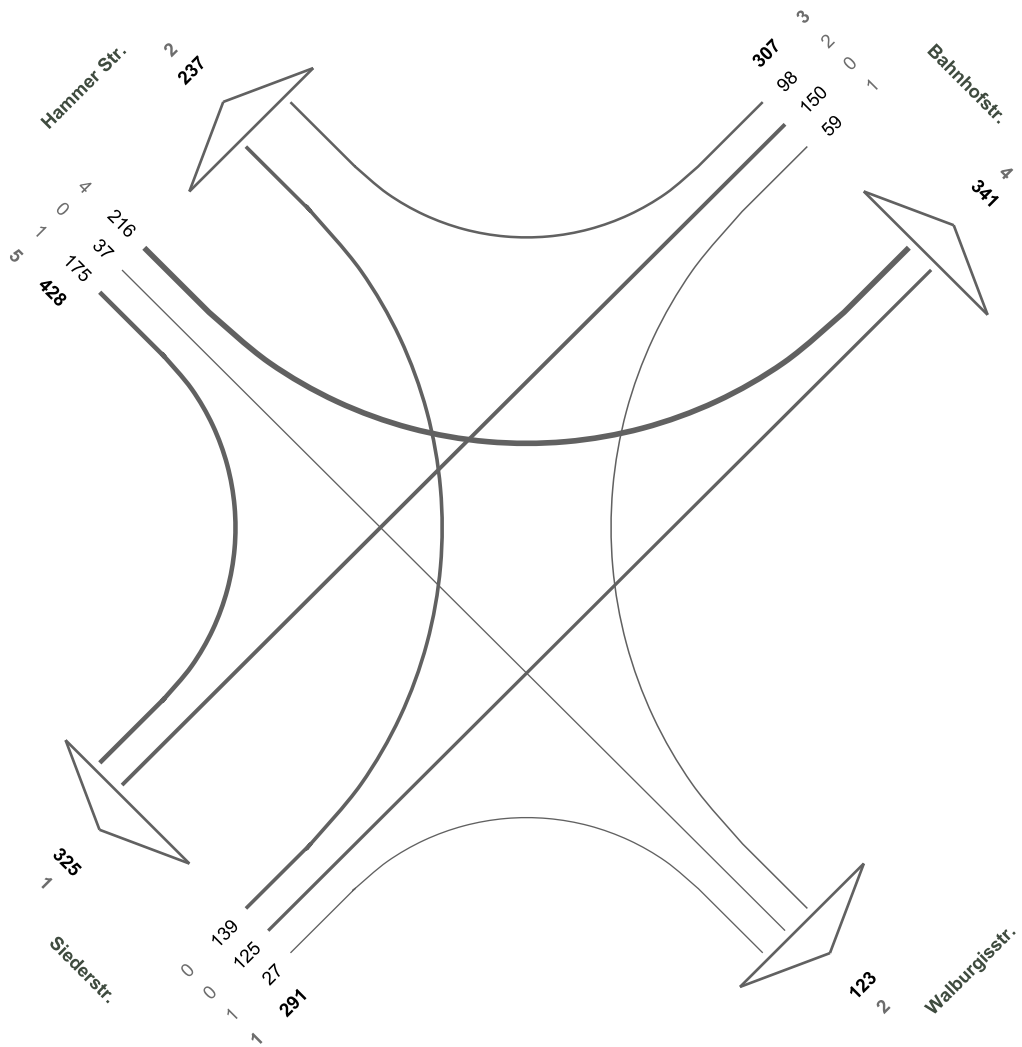

08 - Bahnhofstr. / Hammer Str. / Siederstr.

28.11.2017
15:00 - 19:00 Uhr
4-h-Block
Kfz (SV)

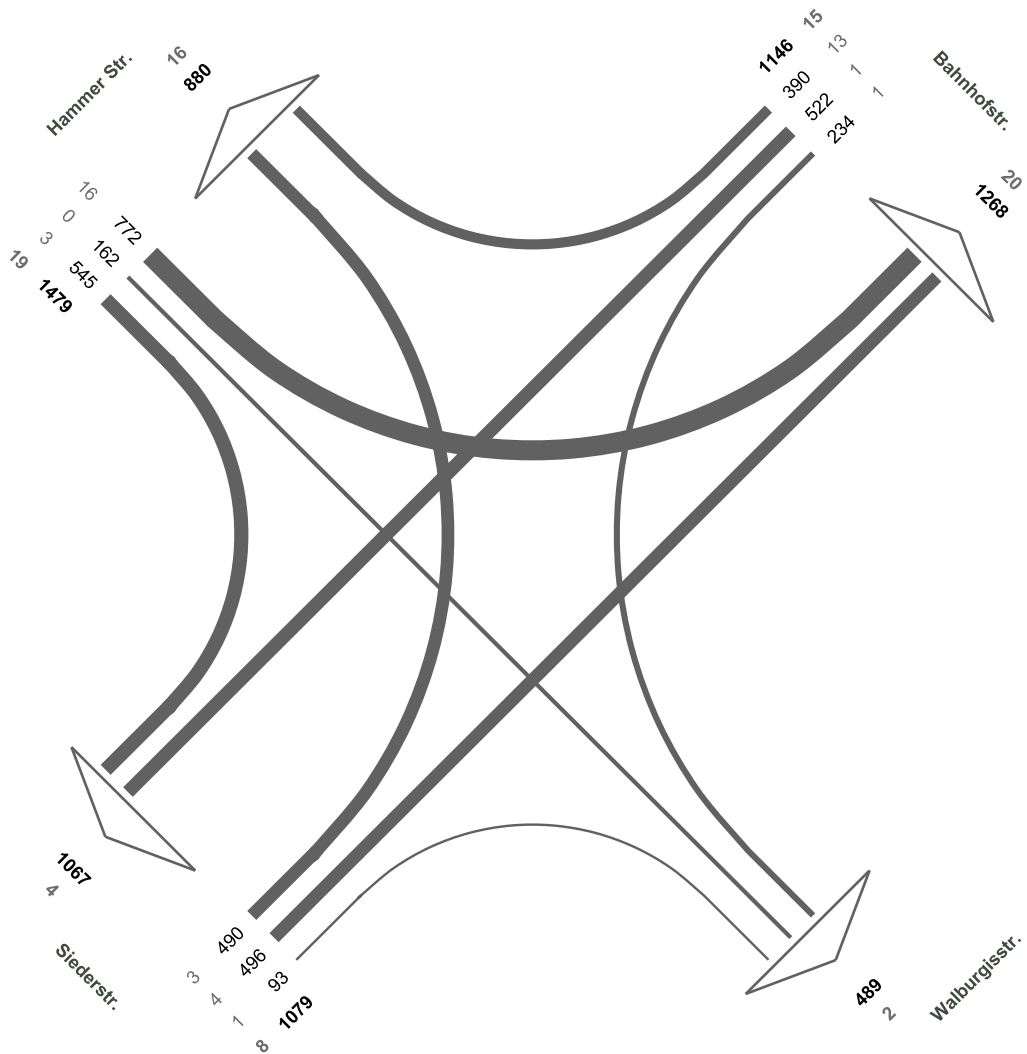

09 - Schützenstr. / Meisterstr. / Hedwig-Dransfeld-Str.

28.11.2017
07:15 - 08:15 Uhr
Morgenspitze
Kfz (SV)

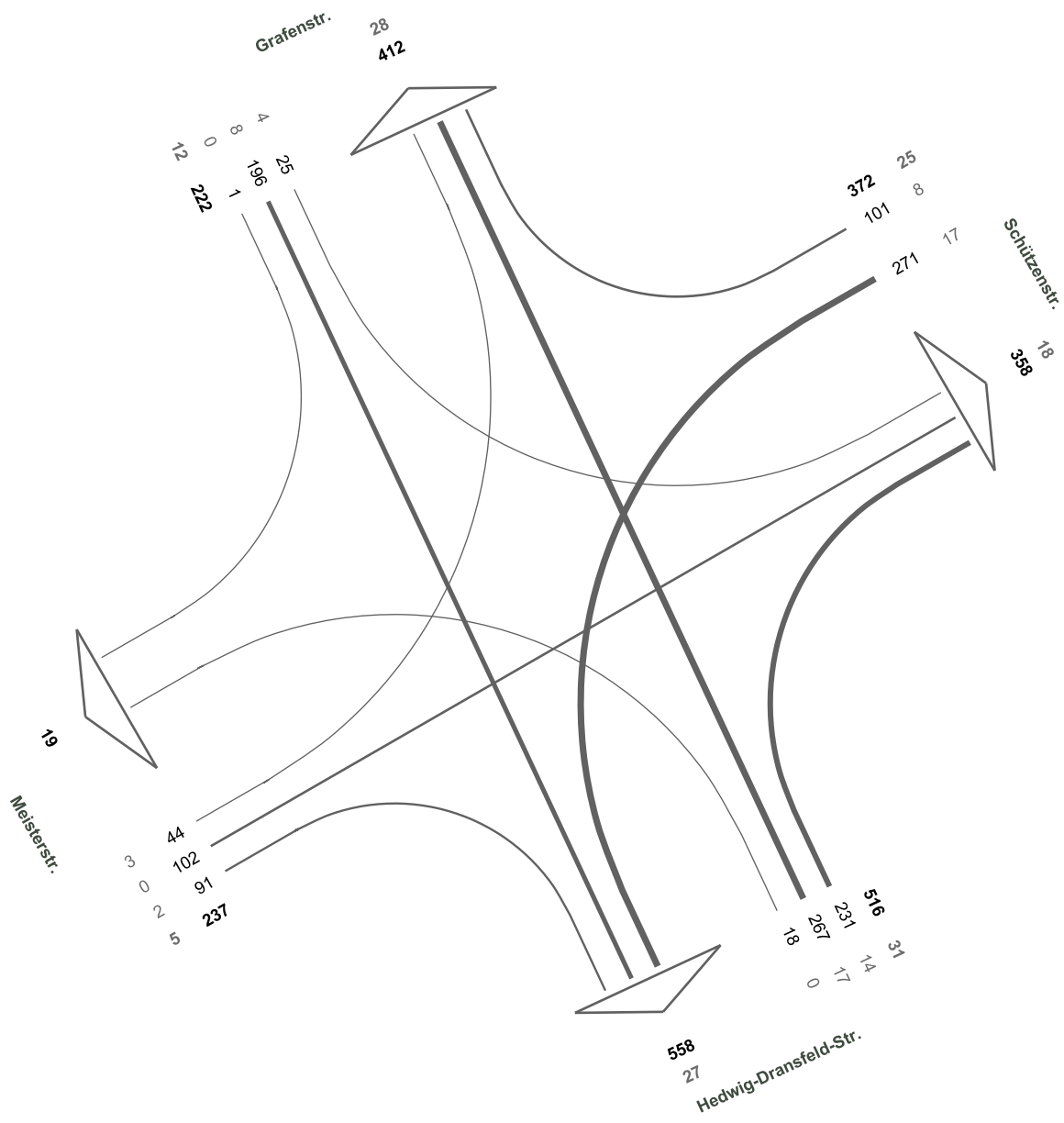

09 - Schützenstr. / Meisterstr. / Hedwig-Dransfeld-Str.

28.11.2017
06:00 - 10:00 Uhr
4-h-Block
Kfz (SV)

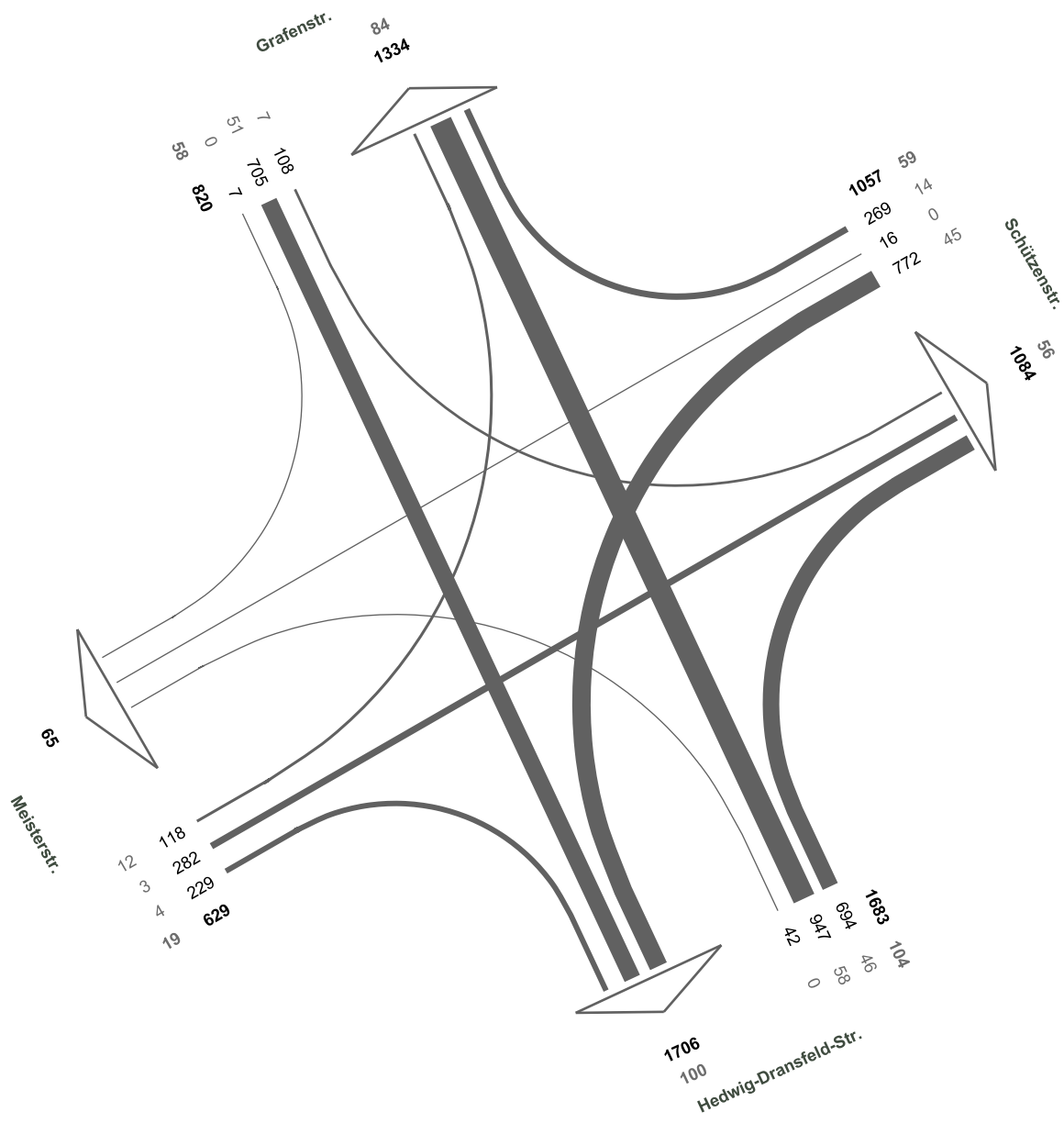

09 - Schützenstr. / Meisterstr. / Hedwig-Dransfeld-Str.

28.11.2017
15:45 - 16:45 Uhr
Abendspitze
Kfz (SV)

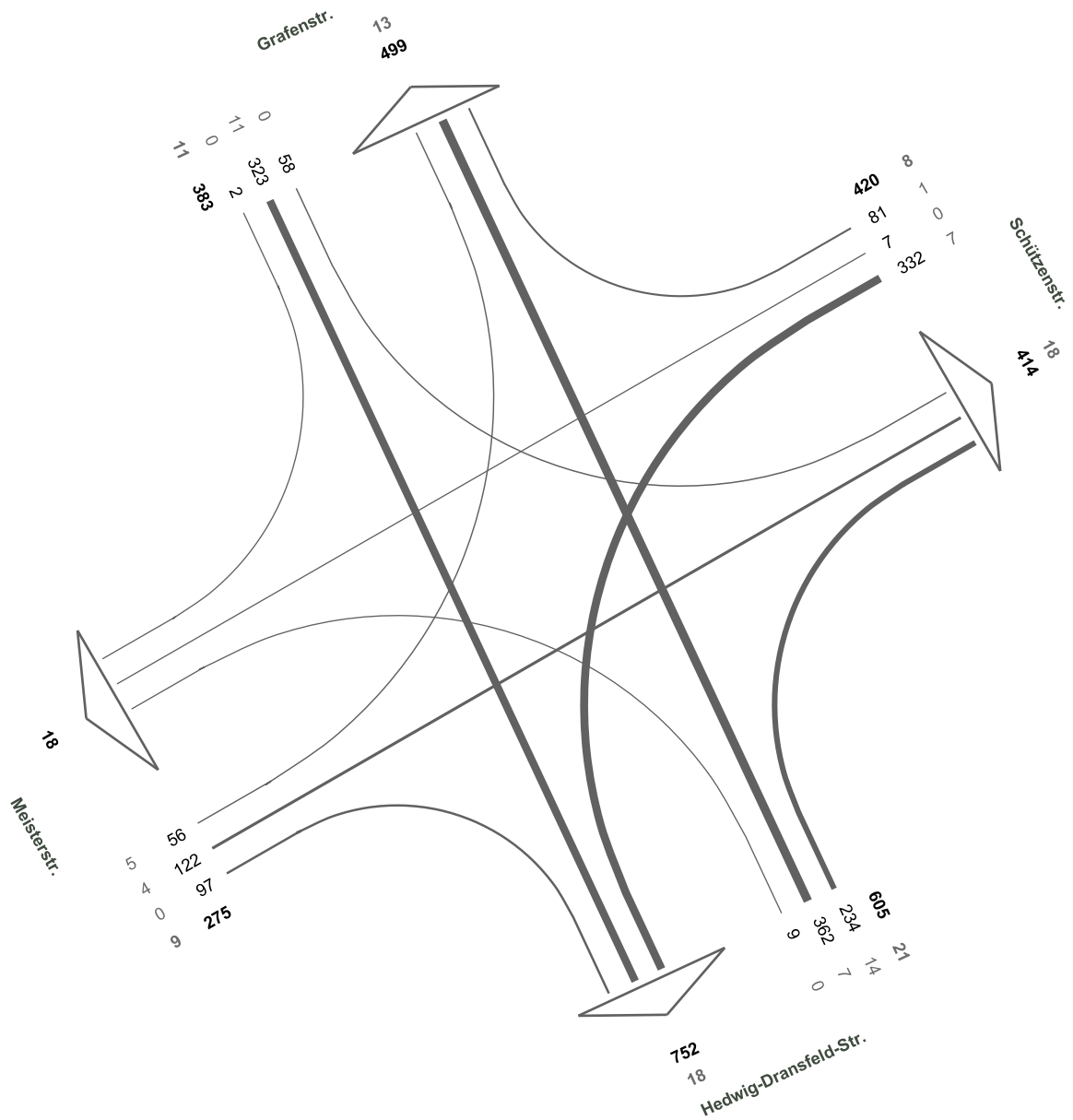

09 - Schützenstr. / Meisterstr. / Hedwig-Dransfeld-Str.

28.11.2017
15:00 - 19:00 Uhr
4-h-Block
Kfz (SV)

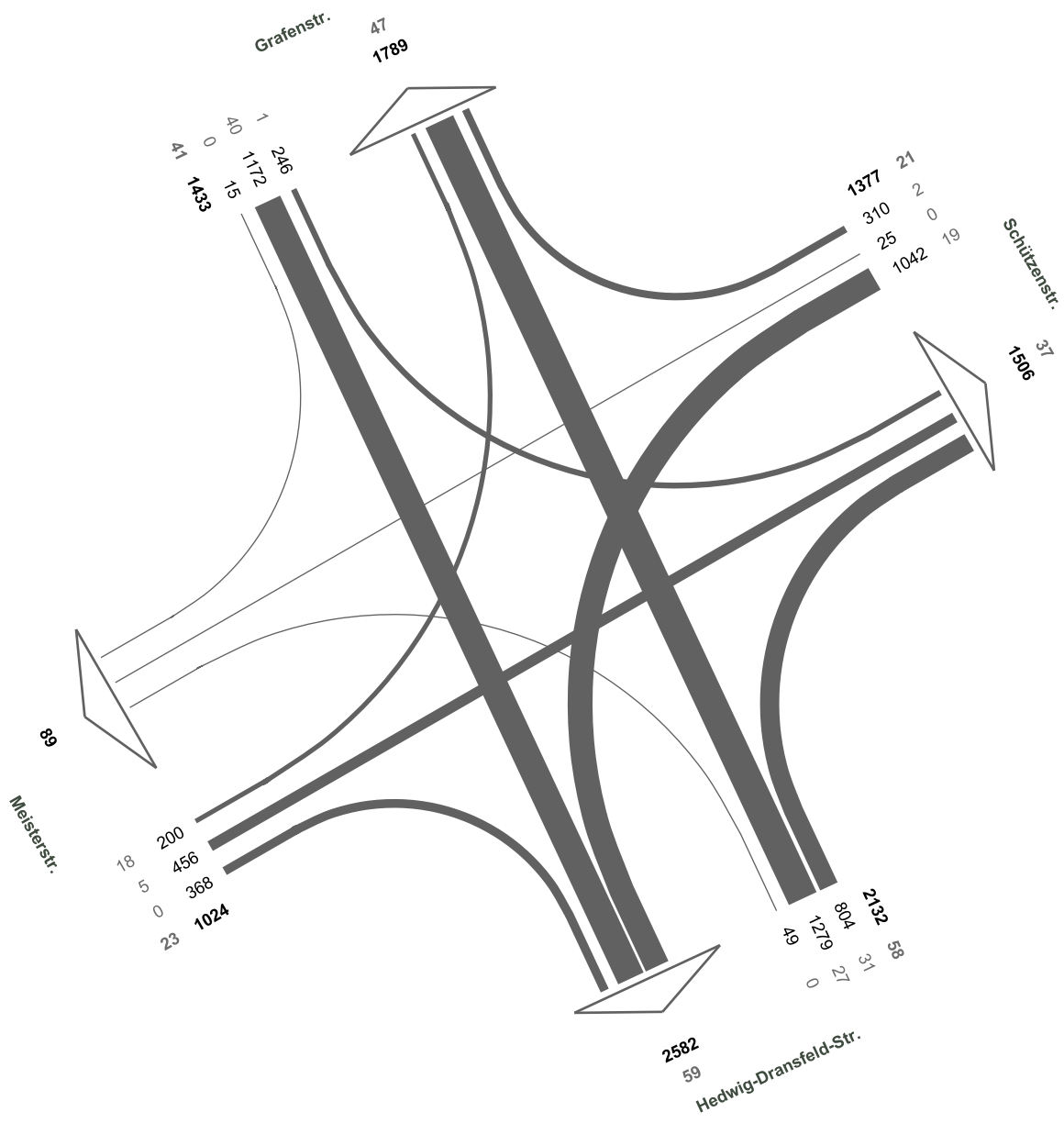

10 - Marktstr. / Bäckerstr.

28.11.2017
09:00 - 10:00 Uhr
Morgenspitze
Kfz (SV)

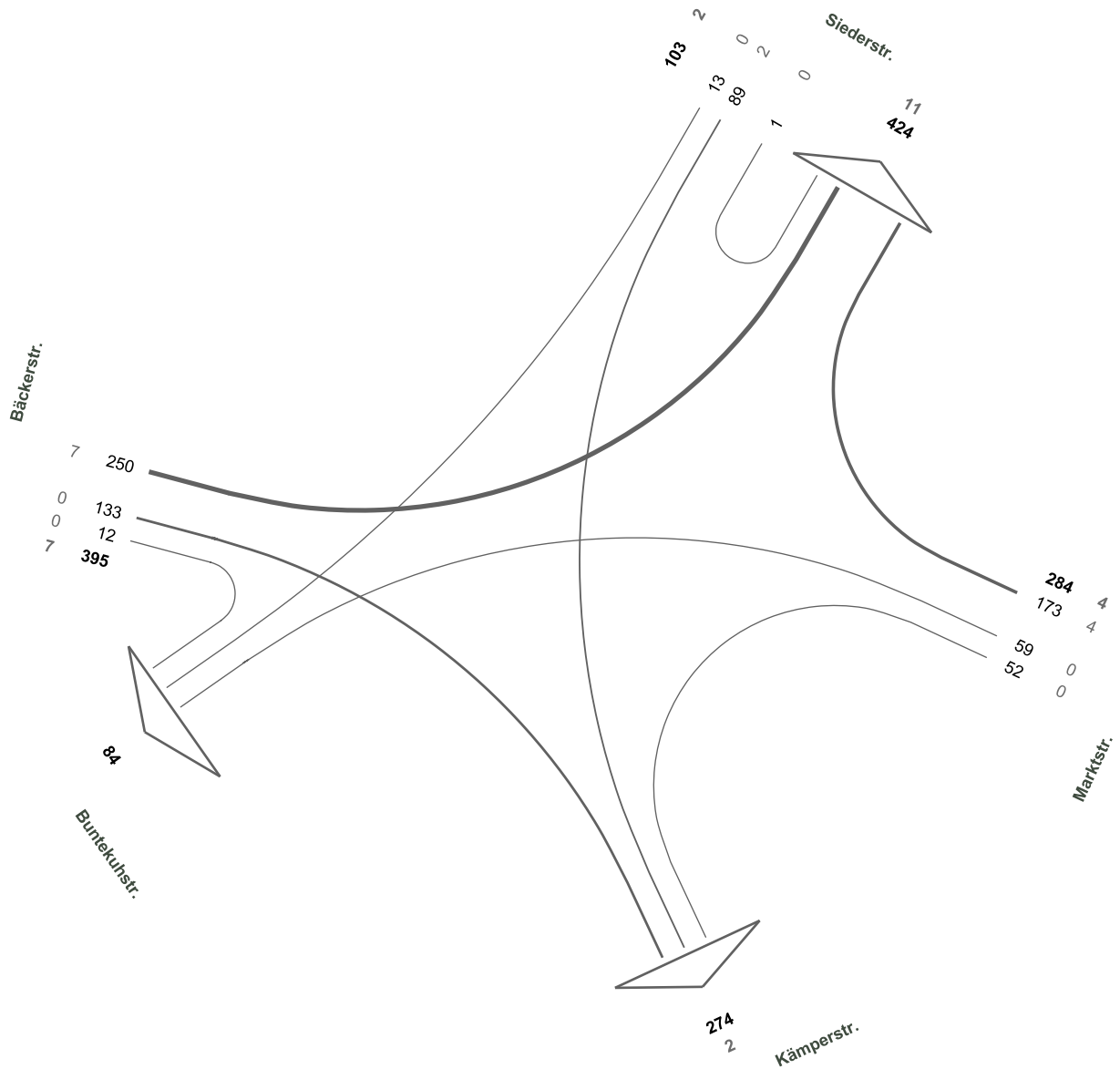

10 - Marktstr. / Bäckerstr.

28.11.2017
06:00 - 10:00 Uhr
4-h-Block
Kfz (SV)

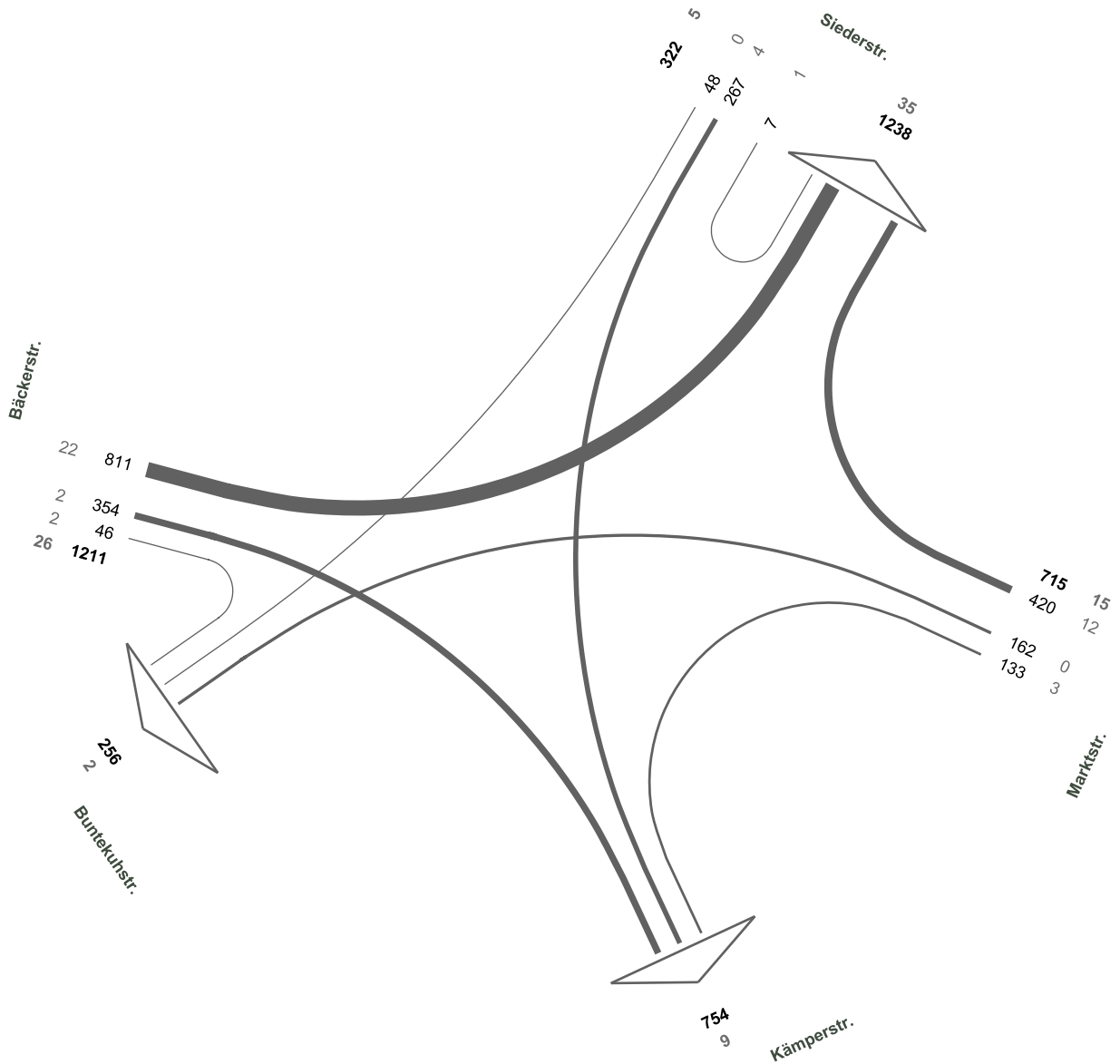

10 - Marktstr. / Bäckerstr.

28.11.2017
15:15 - 16:15 Uhr
Abendspitze
Kfz (SV)

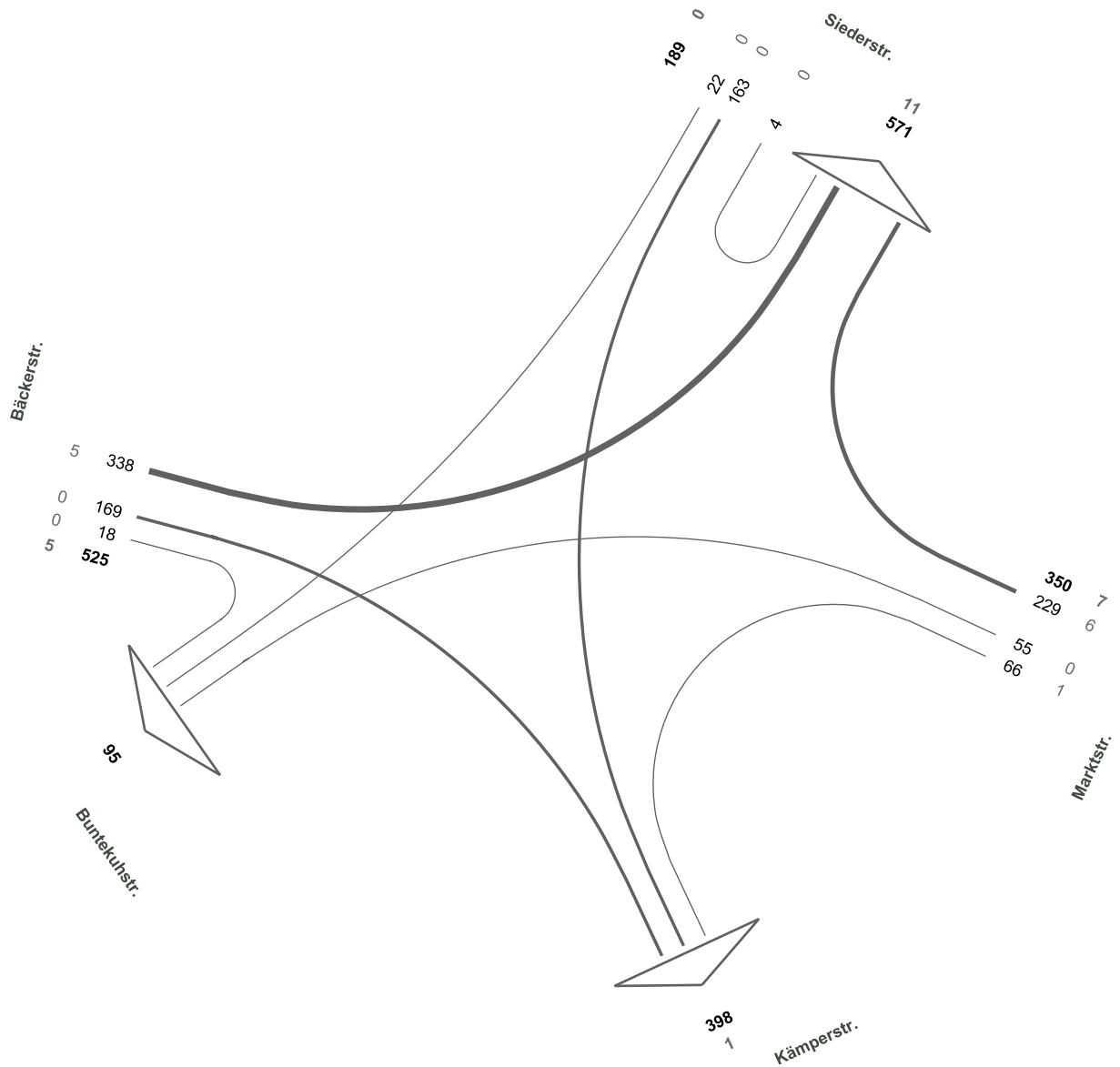

10 - Marktstr. / Bäckerstr.

28.11.2017
15:00 - 19:00 Uhr
4-h-Block
Kfz (SV)

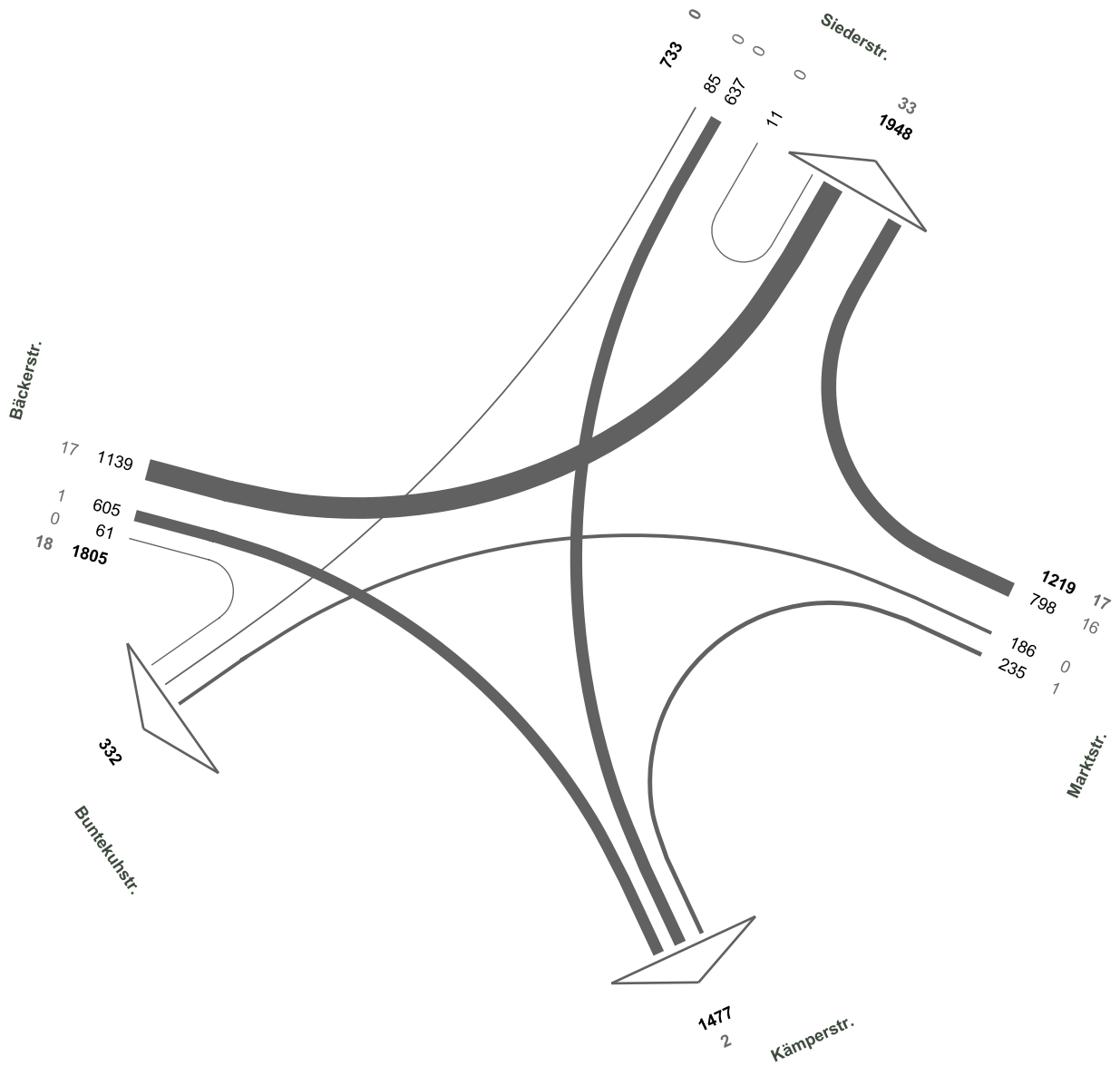

11 - Unnaer Str. / Westuffler Weg / Salinenring

28.11.2017
07:15 - 08:15 Uhr
Morgenspitze
Kfz (SV)

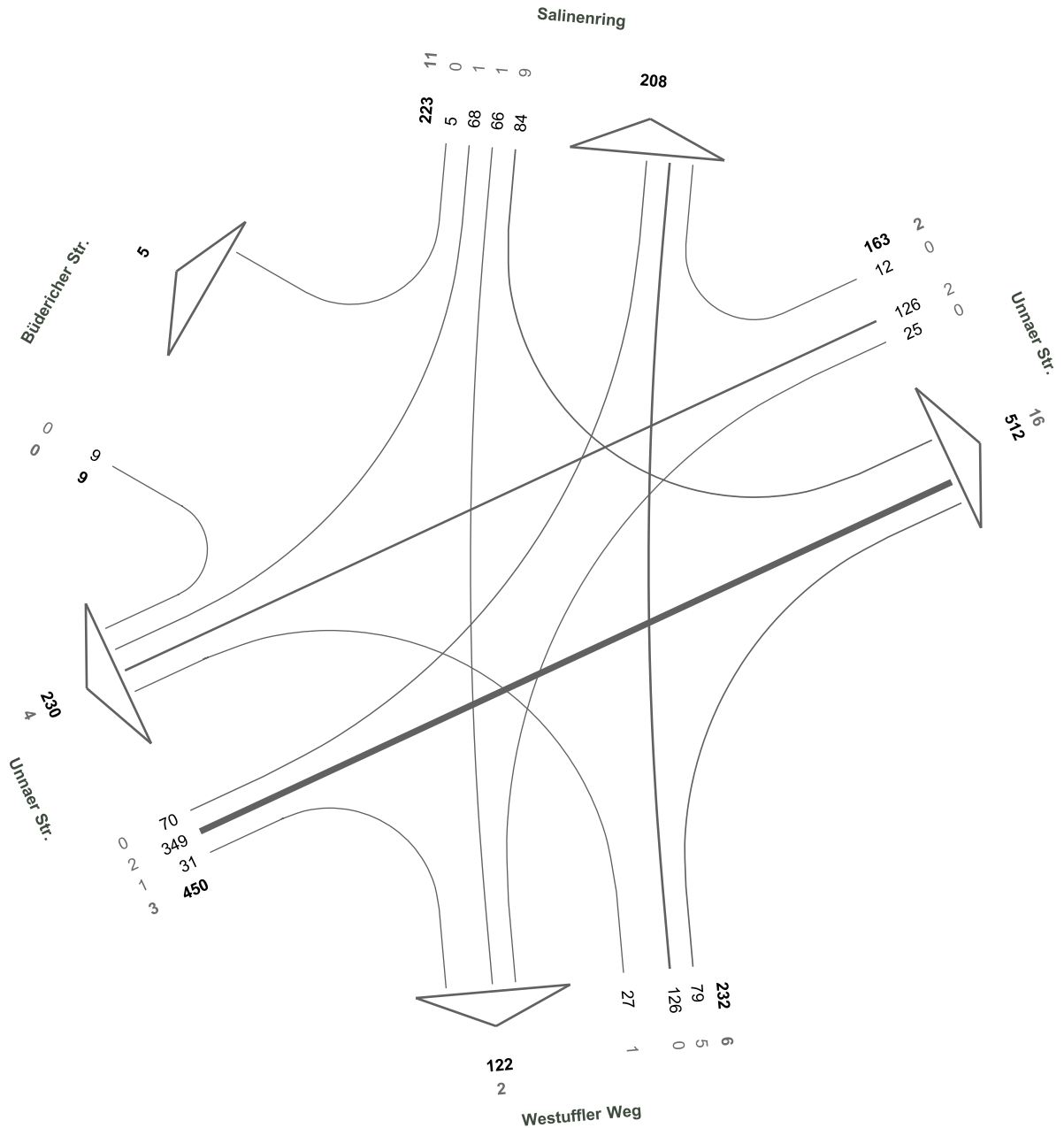

11 - Unnaer Str. / Westuffler Weg / Salinenring

28.11.2017
06:00 - 10:00 Uhr
4-h-Block
Kfz (SV)

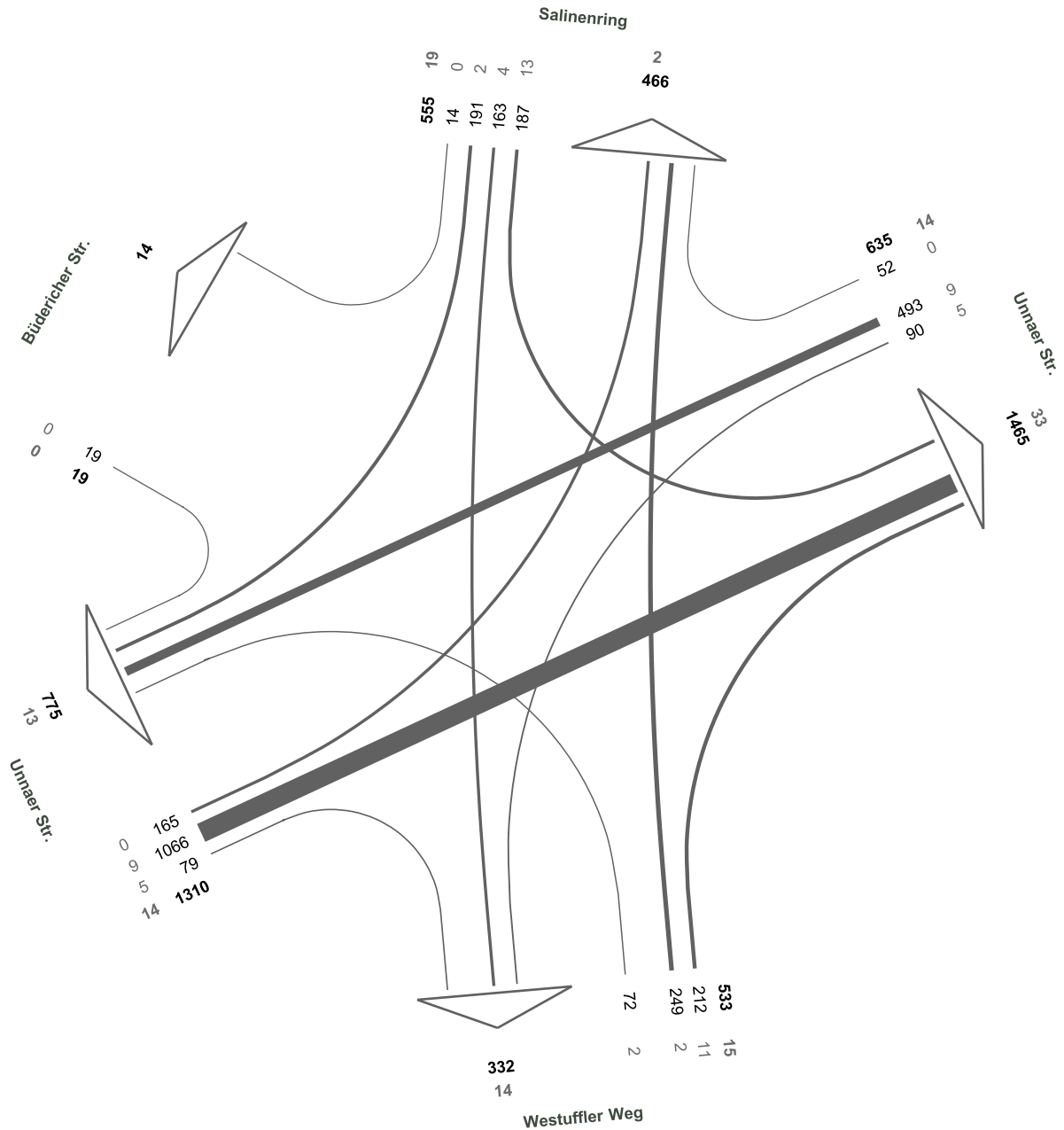

11 - Unnaer Str. / Westuffler Weg / Salinenring

28.11.2017
16:30 - 17:30 Uhr
Abendspitze
Kfz (SV)

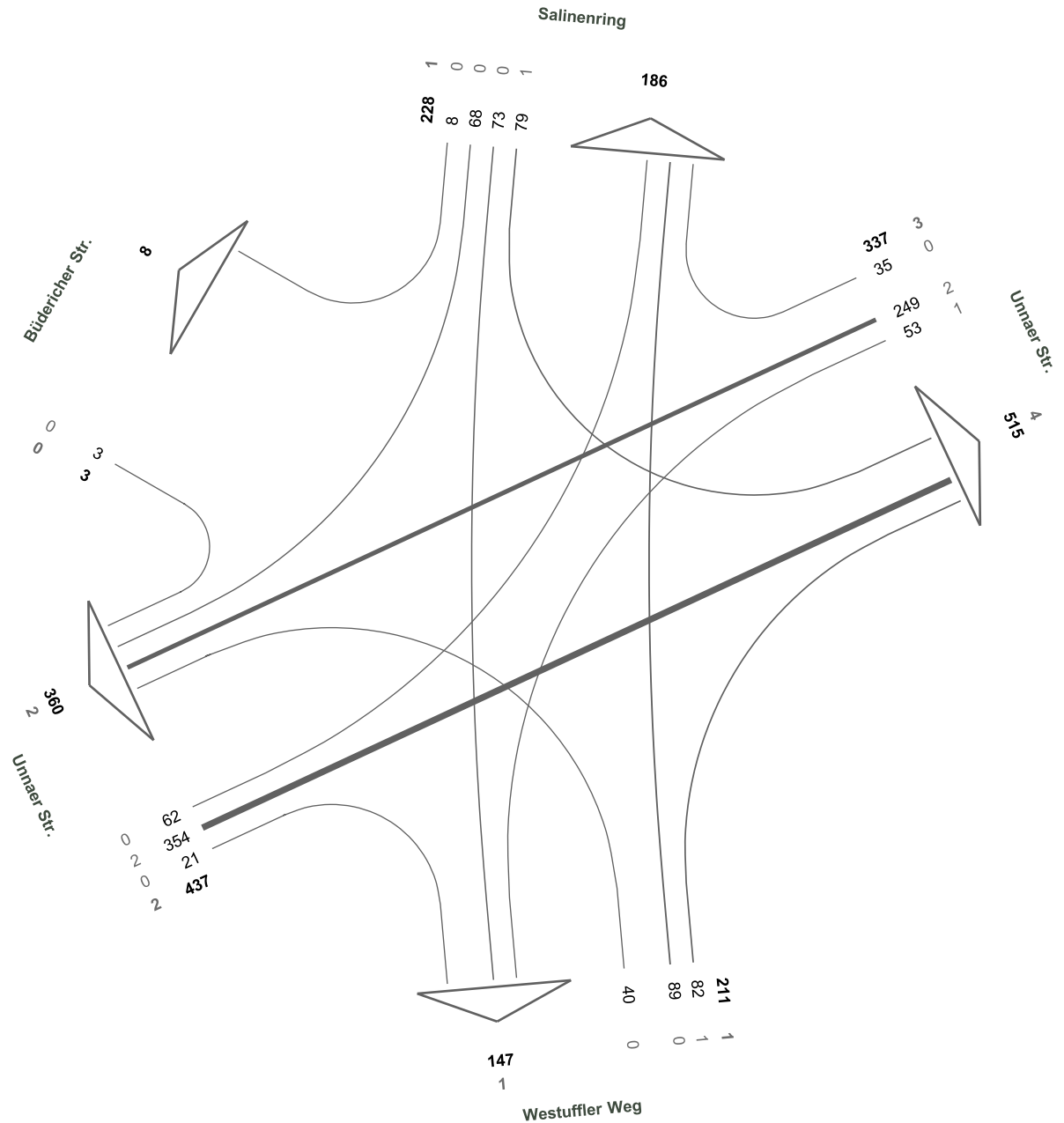

11 - Unnaer Str. / Westuffler Weg / Salinenring

28.11.2017
15:00 - 19:00 Uhr
4-h-Block
Kfz (SV)

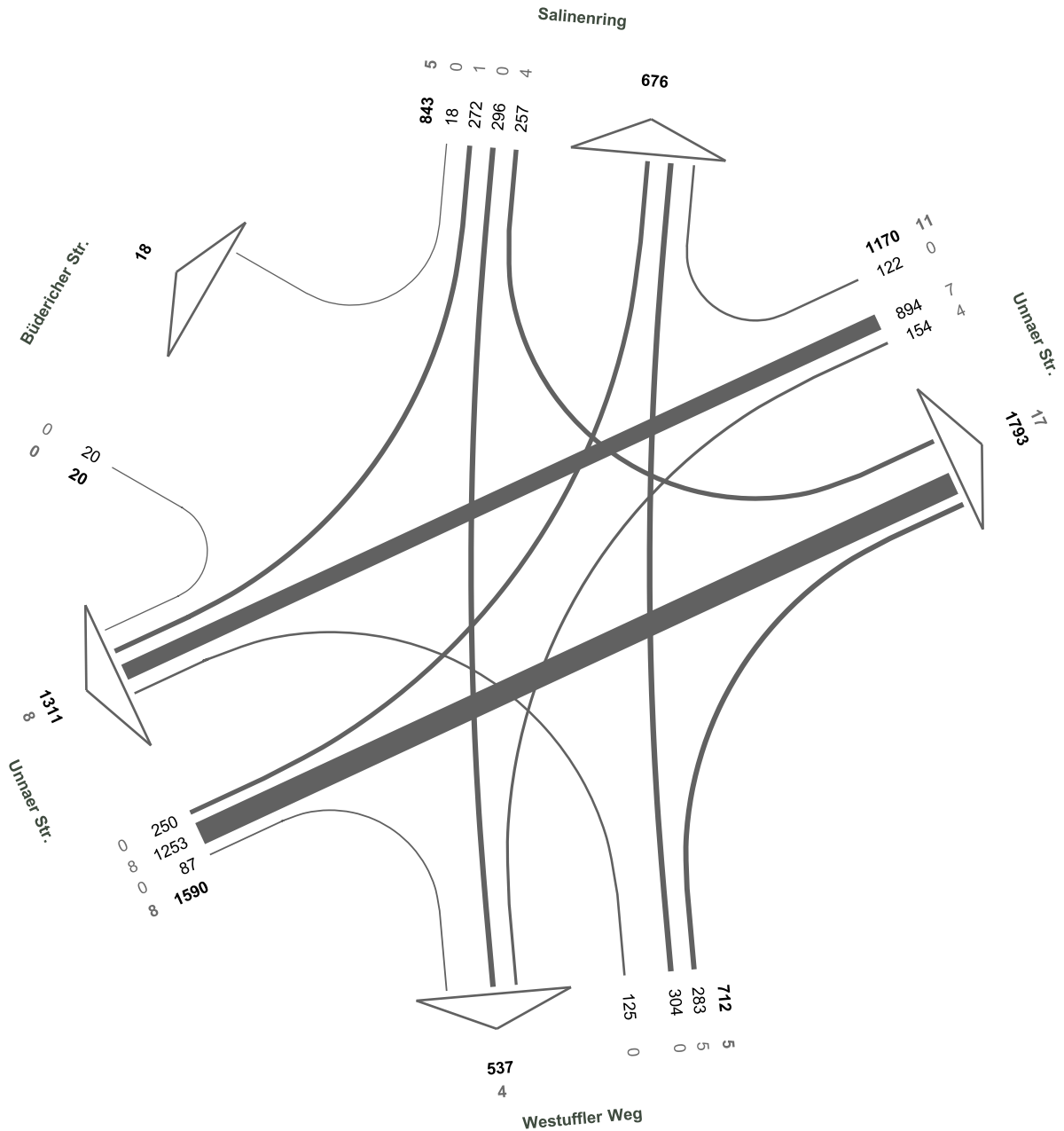

12 - Unnaer Str. / L 969

28.11.2017
07:00 - 08:00 Uhr
Morgenspitze
Kfz (SV)

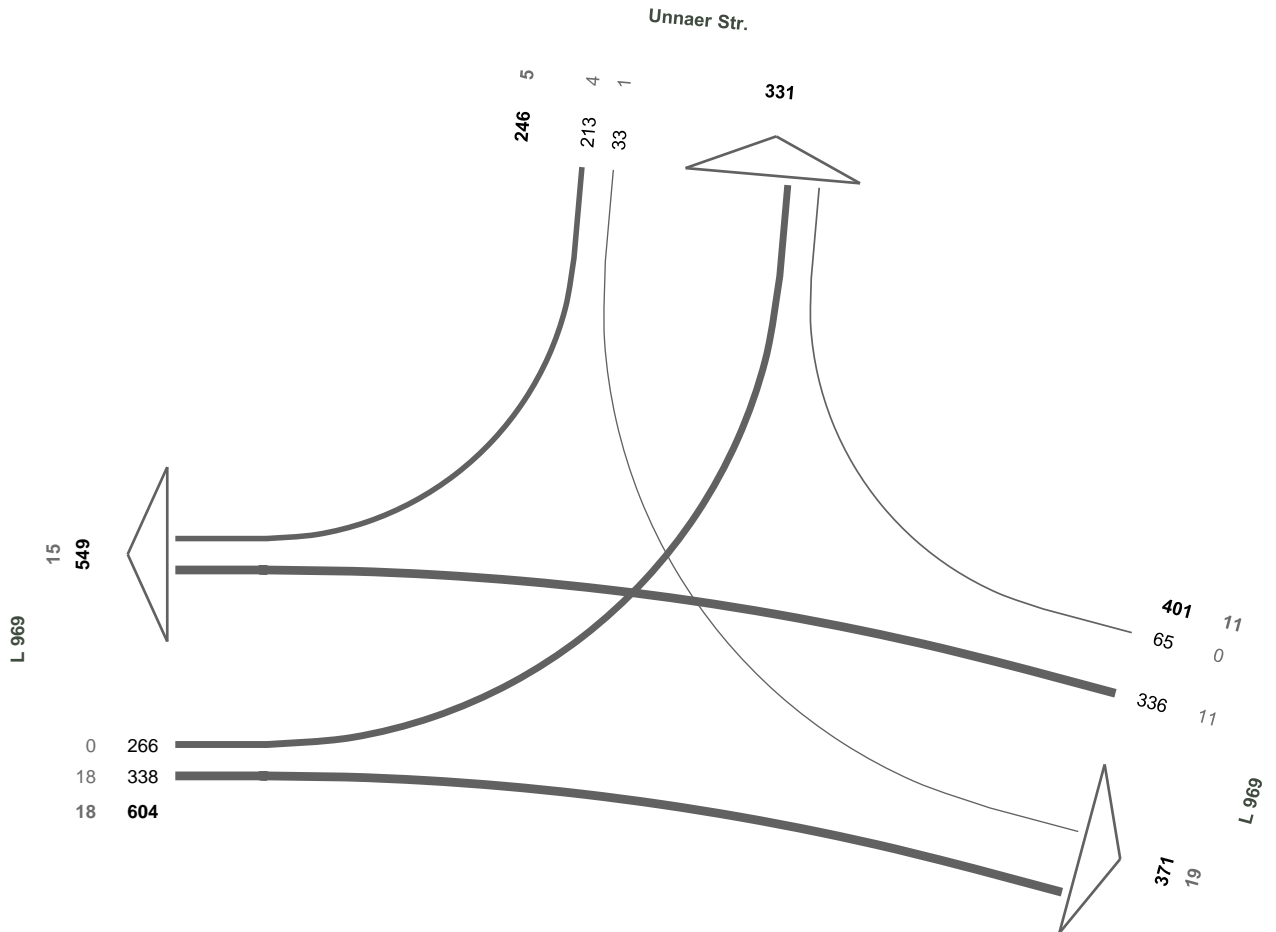

12 - Unnaer Str. / L 969

28.11.2017
06:00 - 10:00 Uhr
4-h-Block
Kfz (SV)

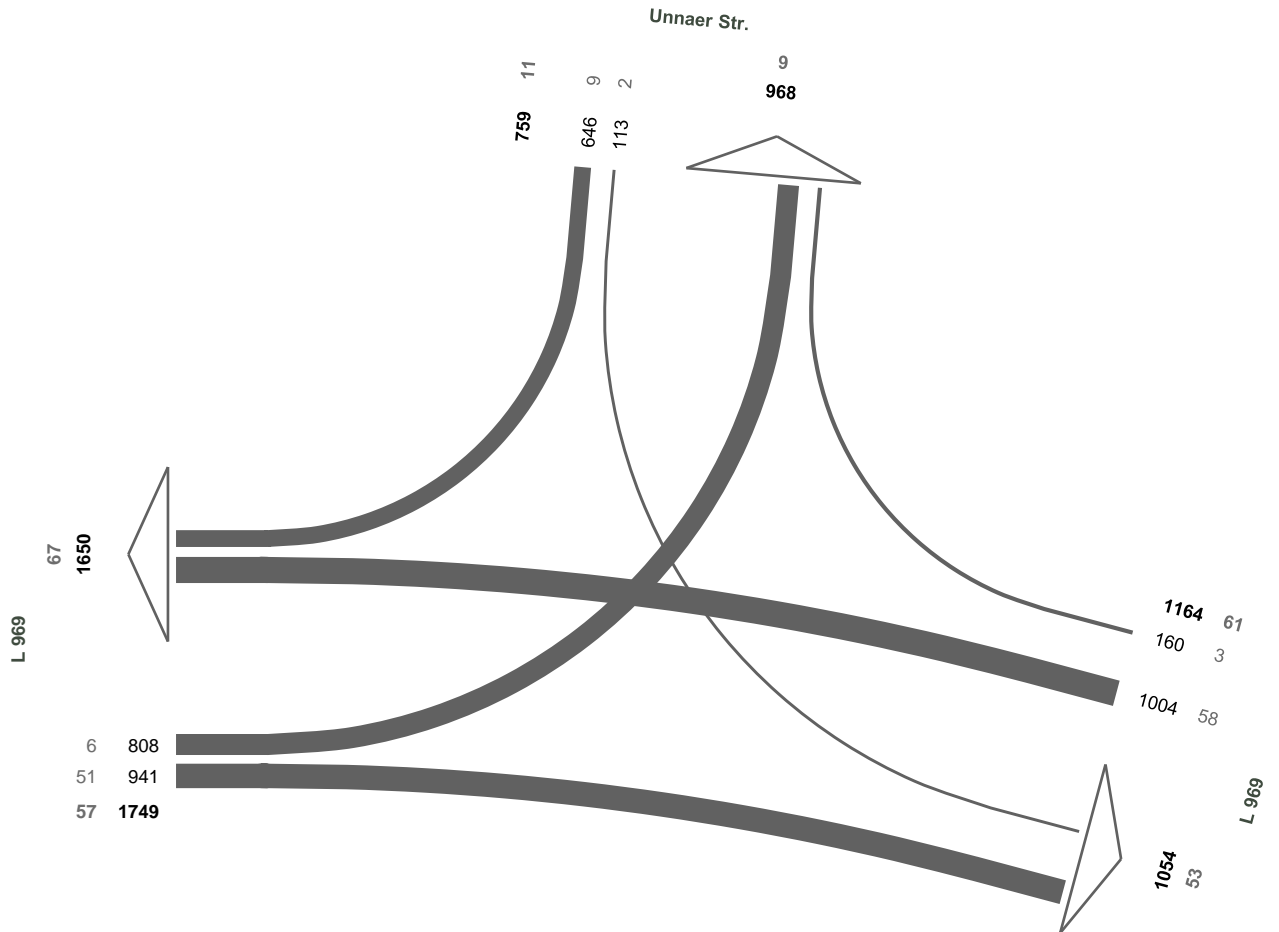

12 - Unnaer Str. / L 969

28.11.2017
15:45 - 16:45 Uhr
Abendspitze
Kfz (SV)

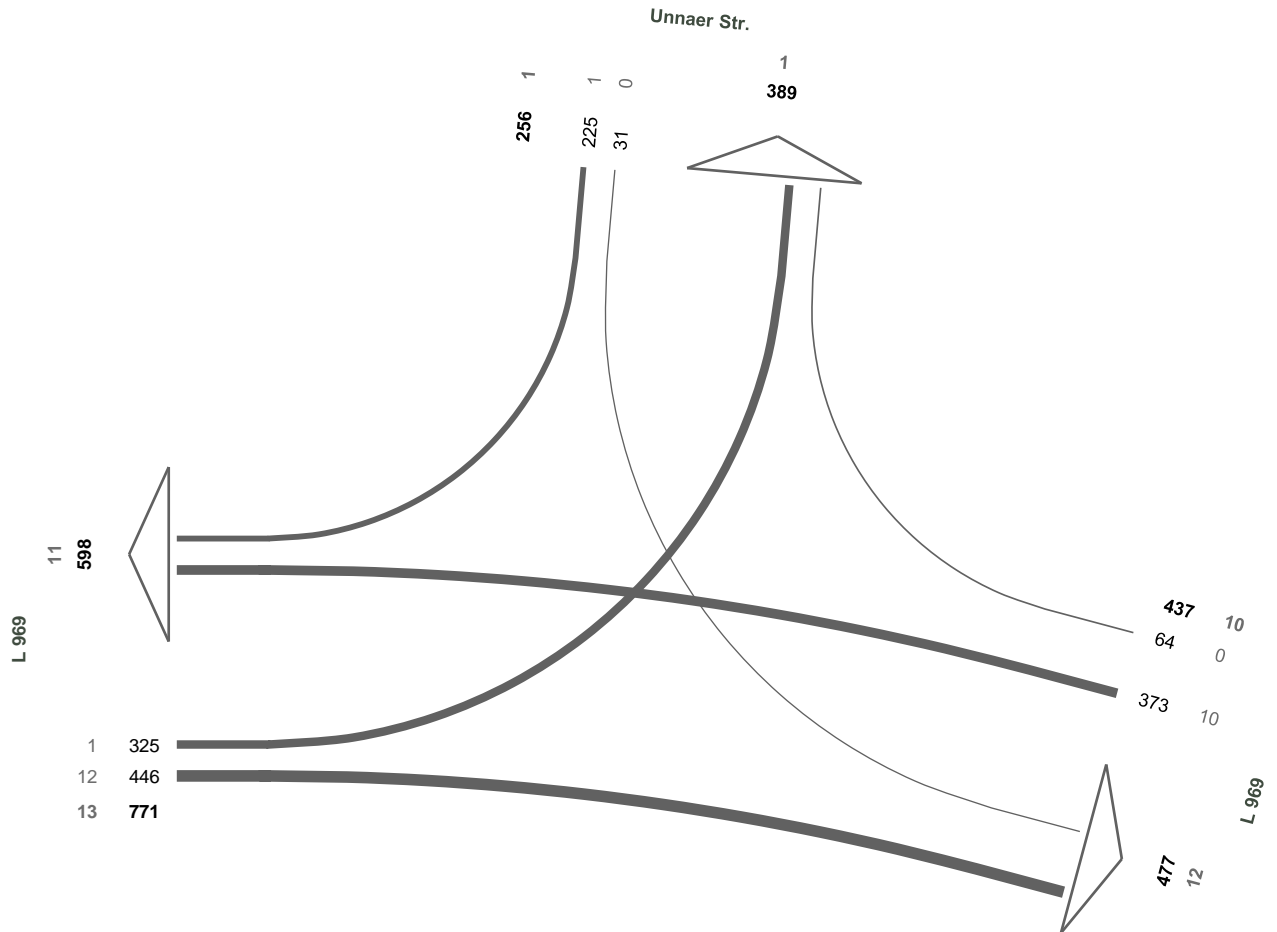

12 - Unnaer Str. / L 969

28.11.2017
15:00 - 19:00 Uhr
4-h-Block
Kfz (SV)

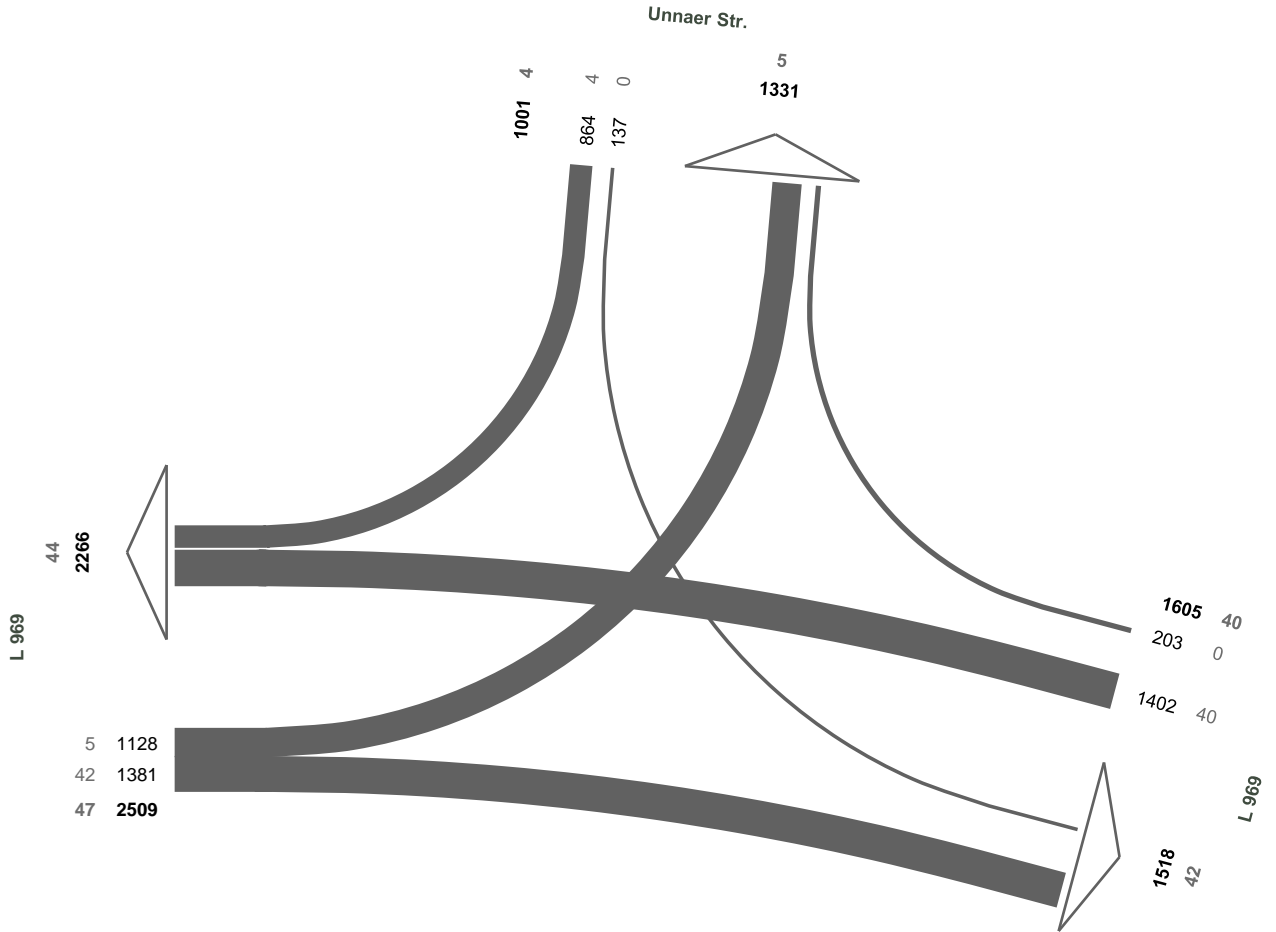

13 - Wickeder Str. / L 969

28.11.2017
07:00 - 08:00 Uhr
Morgenspitze
Kfz (SV)

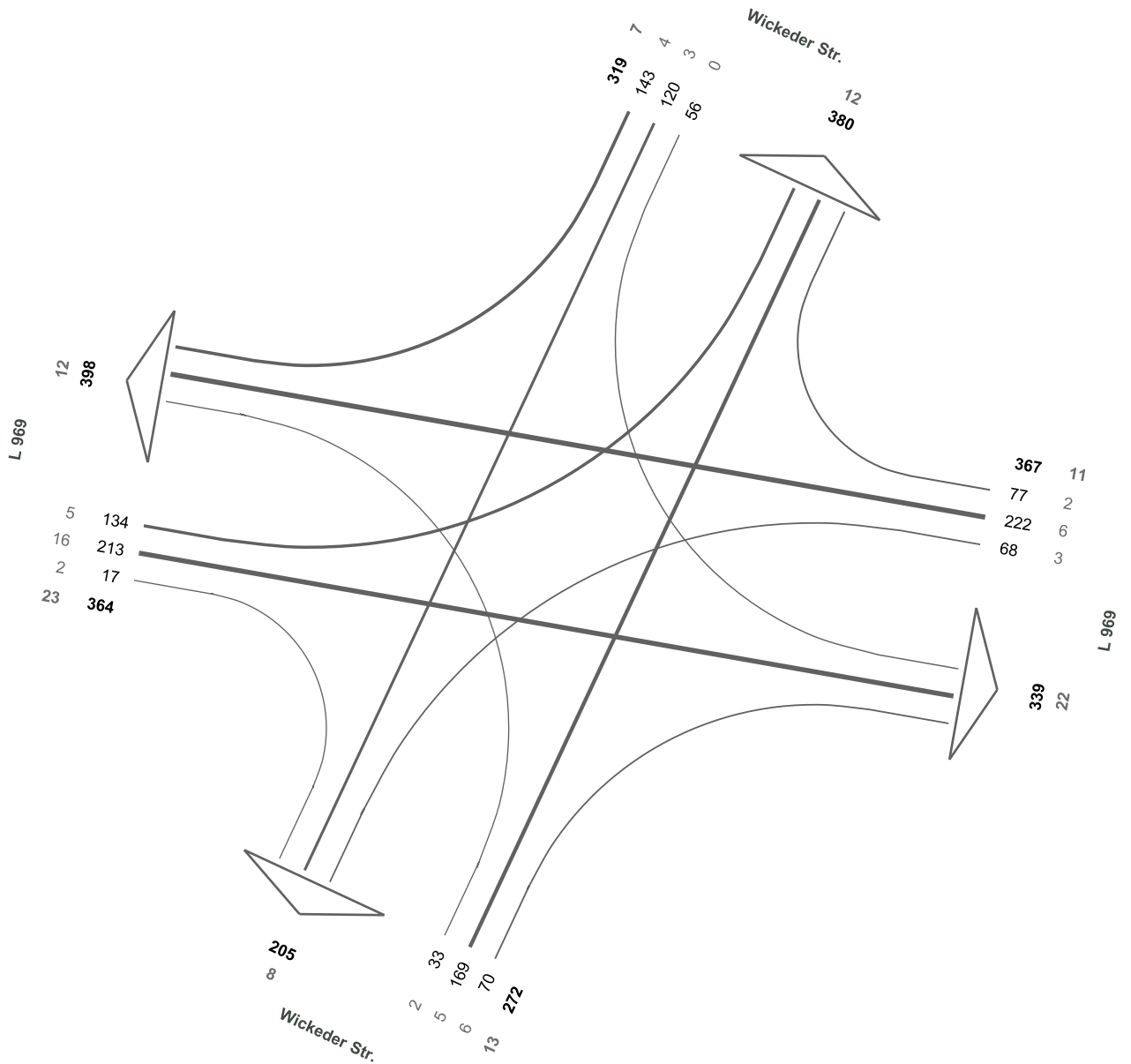

13 - Wickeder Str. / L 969

28.11.2017
06:00 - 10:00 Uhr
4-h-Block
Kfz (SV)

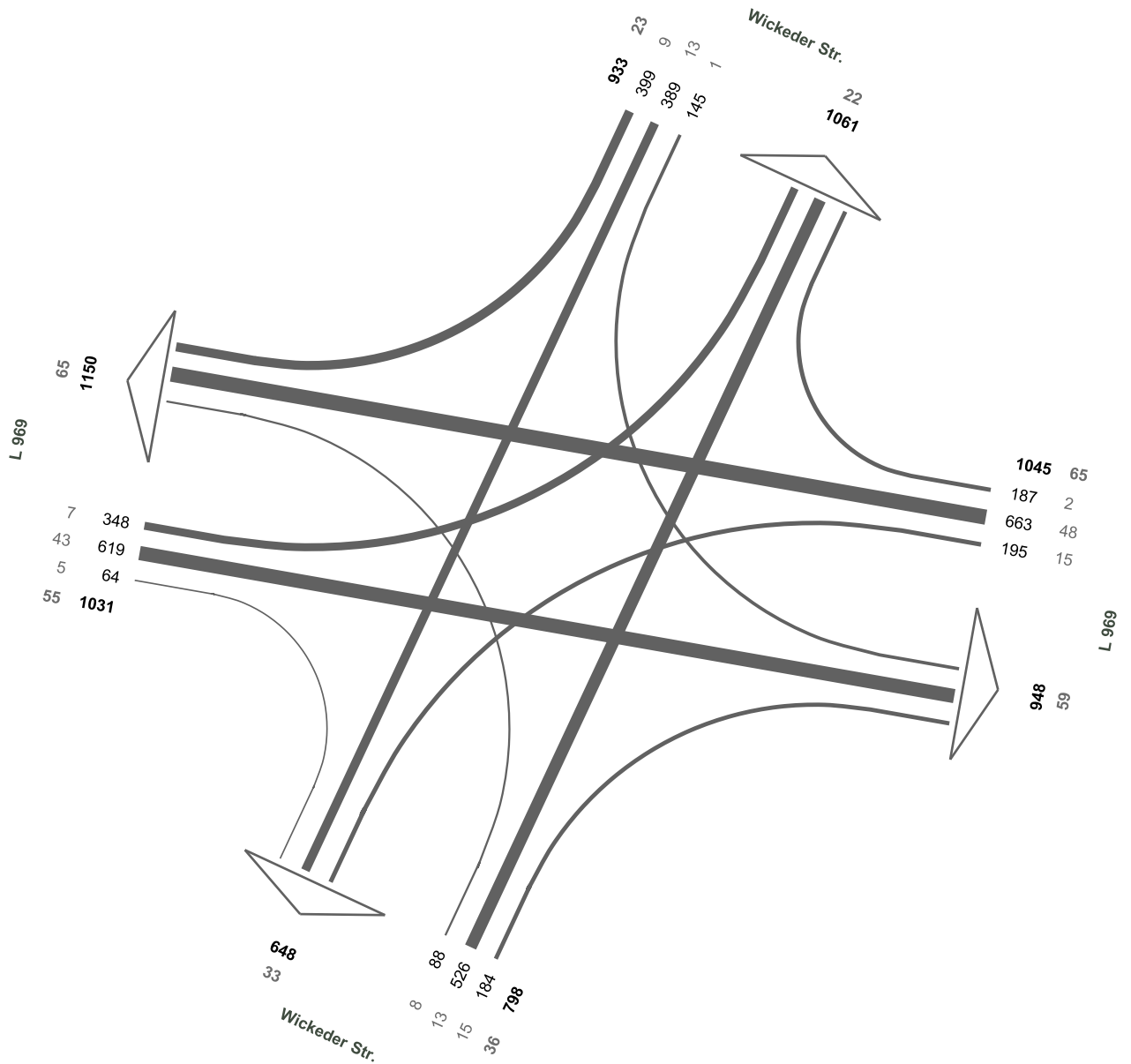

13 - Wickeder Str. / L 969

28.11.2017
15:45 - 16:45 Uhr
Abendspitze
Kfz (SV)

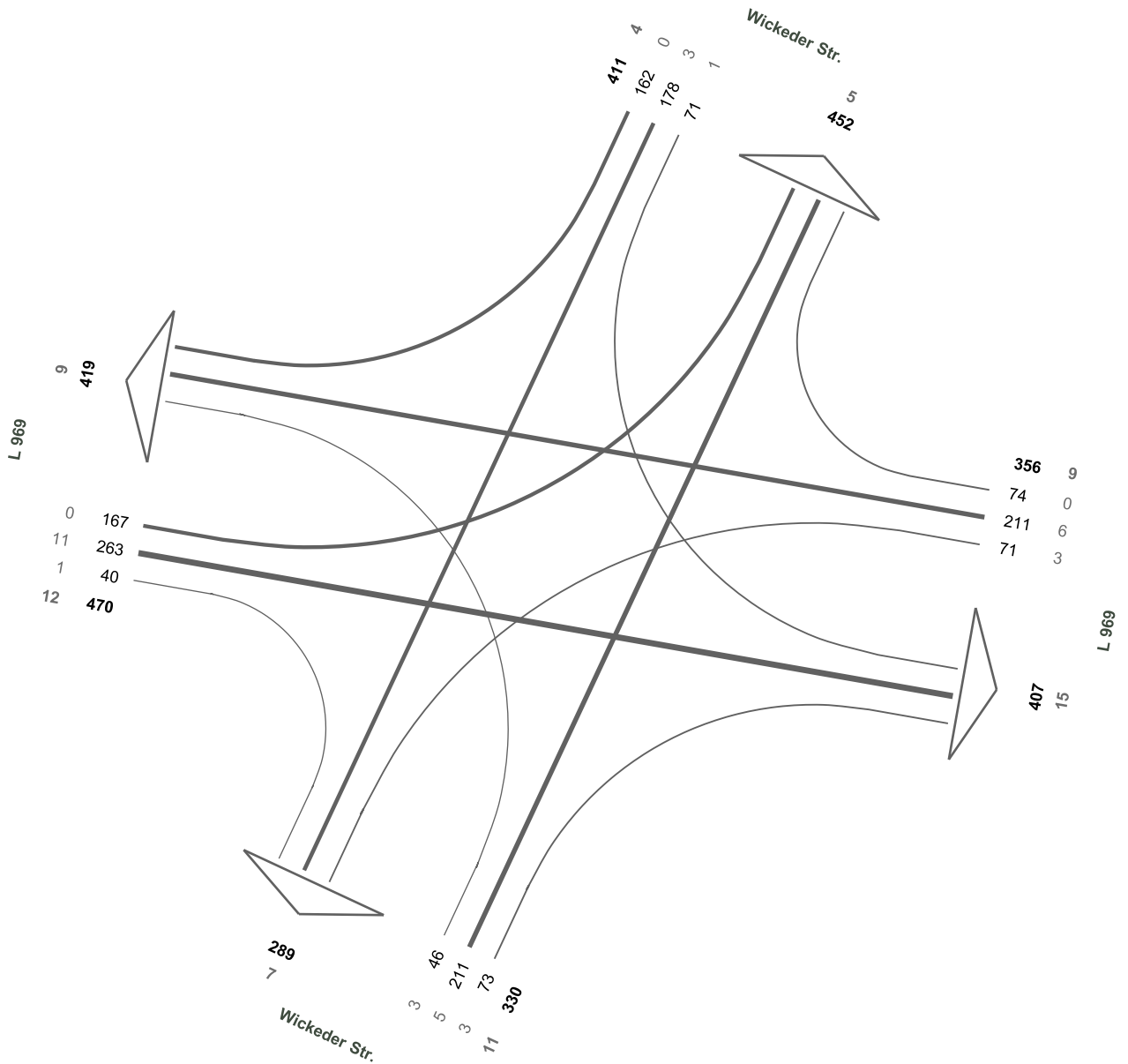

13 - Wickeder Str. / L 969

28.11.2017
15:00 - 19:00 Uhr
4-h-Block
Kfz (SV)

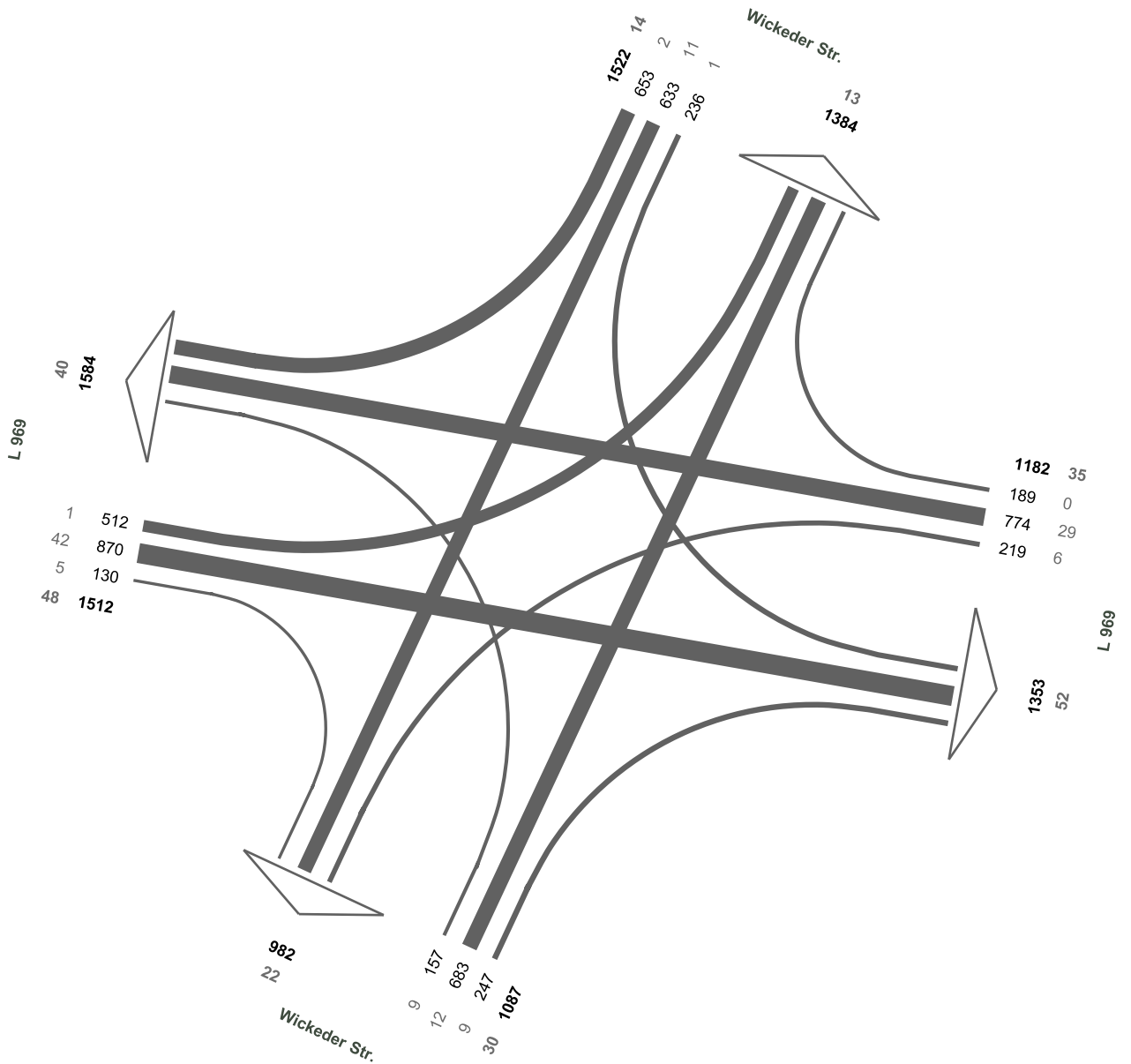

14 - L 969 / Neheimer Str.

28.11.2017
07:00 - 08:00 Uhr
Morgenspitze
Kfz (SV)

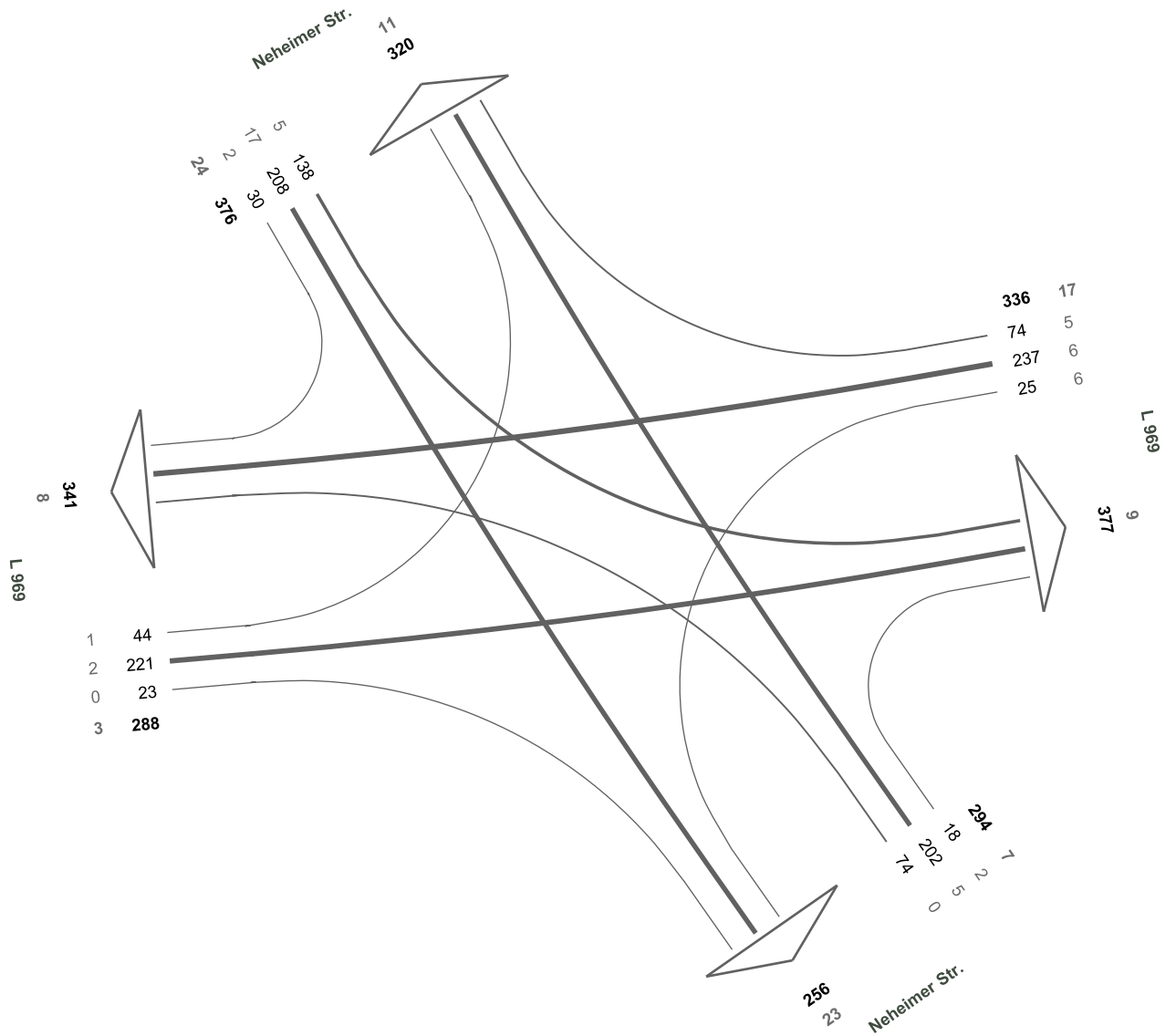

14 - L 969 / Neheimer Str.

28.11.2017
06:00 - 10:00 Uhr
4-h-Block
Kfz (SV)

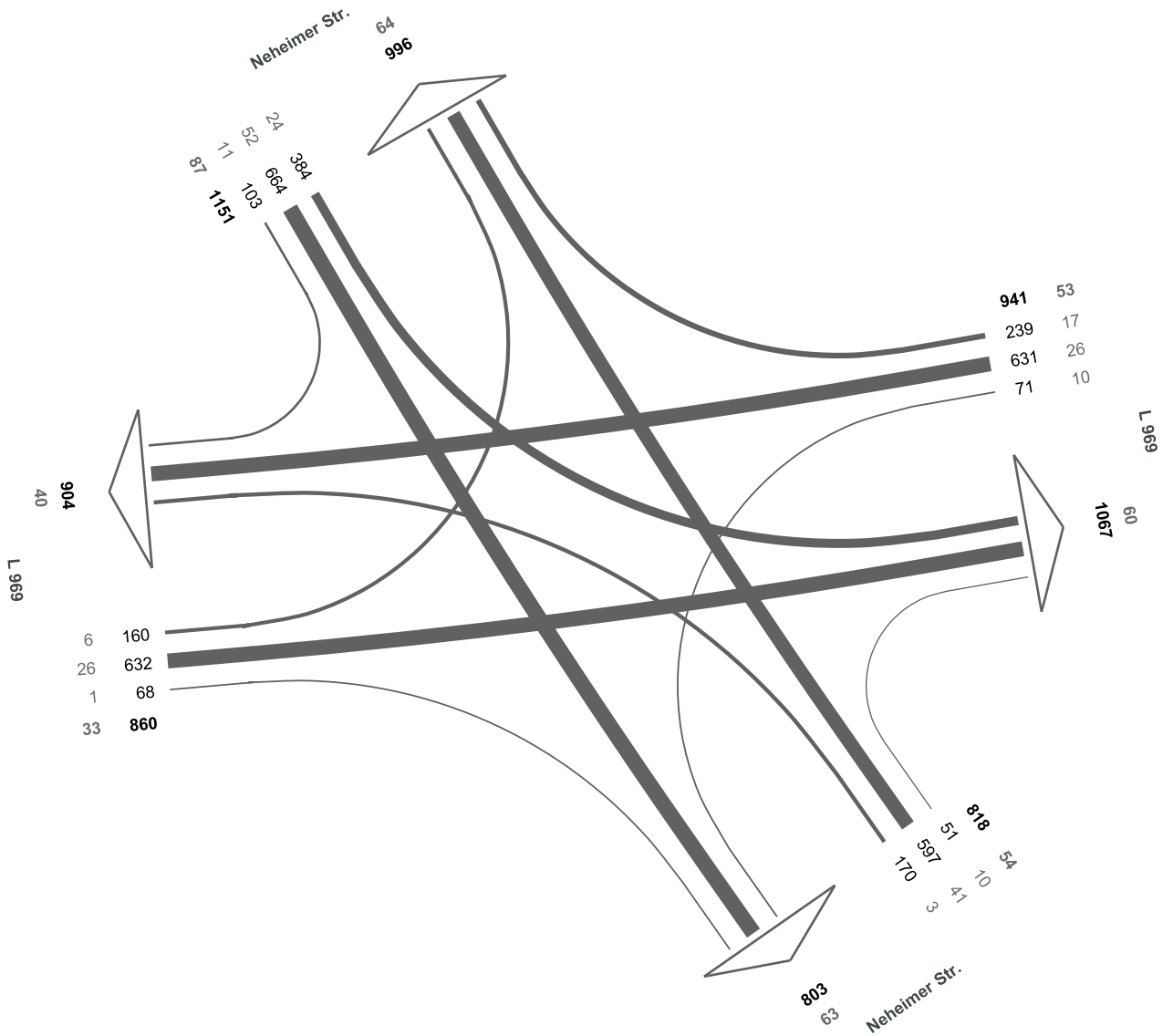

14 - L 969 / Neheimer Str.

28.11.2017
16:15 - 17:15 Uhr
Abendspitze
Kfz (SV)

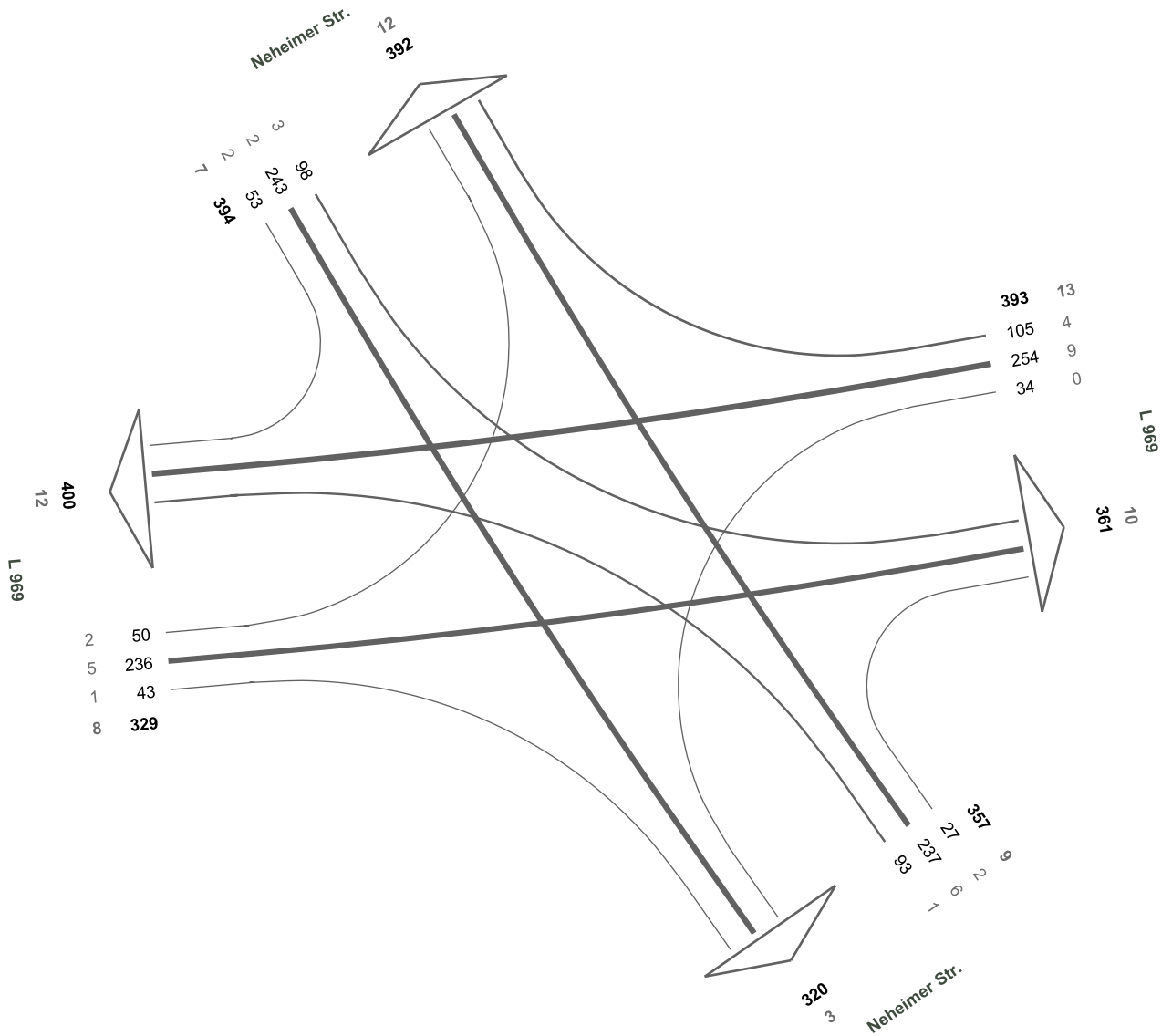

14 - L 969 / Neheimer Str.

28.11.2017
15:00 - 19:00 Uhr
4-h-Block
Kfz (SV)

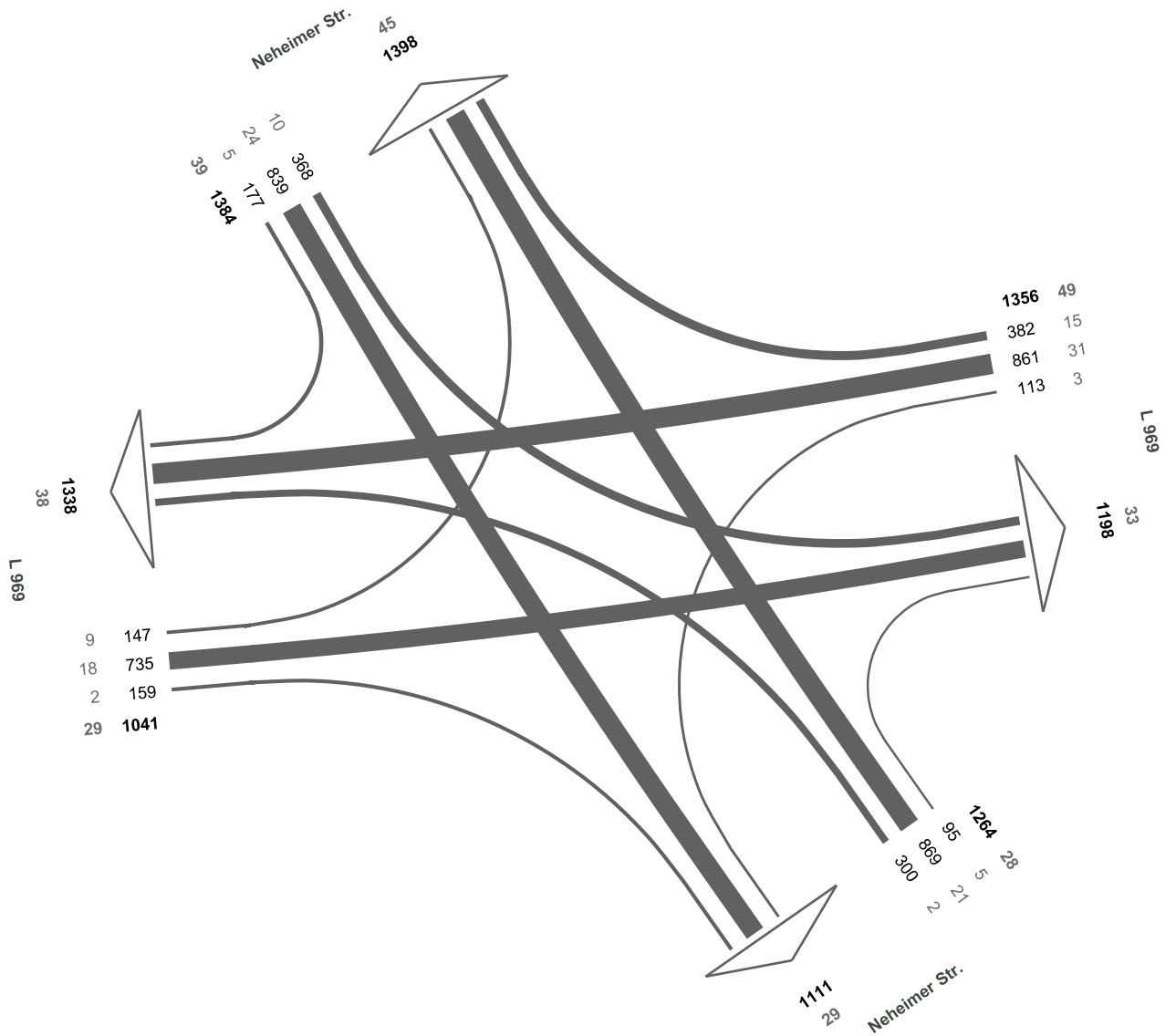

15 - KV Hellweg / Waltringer Str. / Wulf Hefe Str.

28.11.2017
07:15 - 08:15 Uhr
Morgenspitze
Kfz (SV)

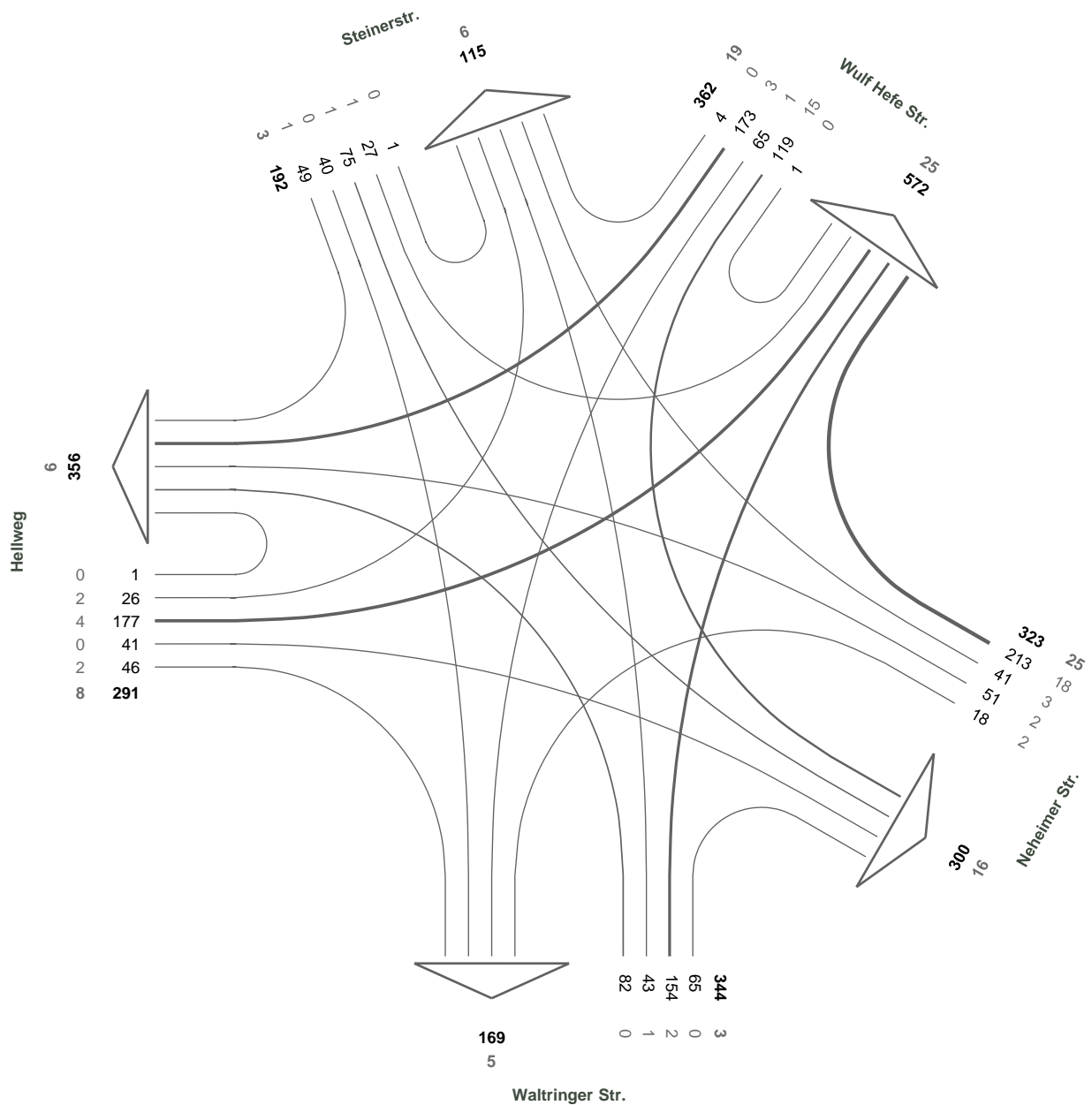

15 - KV Hellweg / Waltringer Str. / Wulf Hefe Str.

28.11.2017
16:15 - 17:15 Uhr
Abendspitze
Kfz (SV)

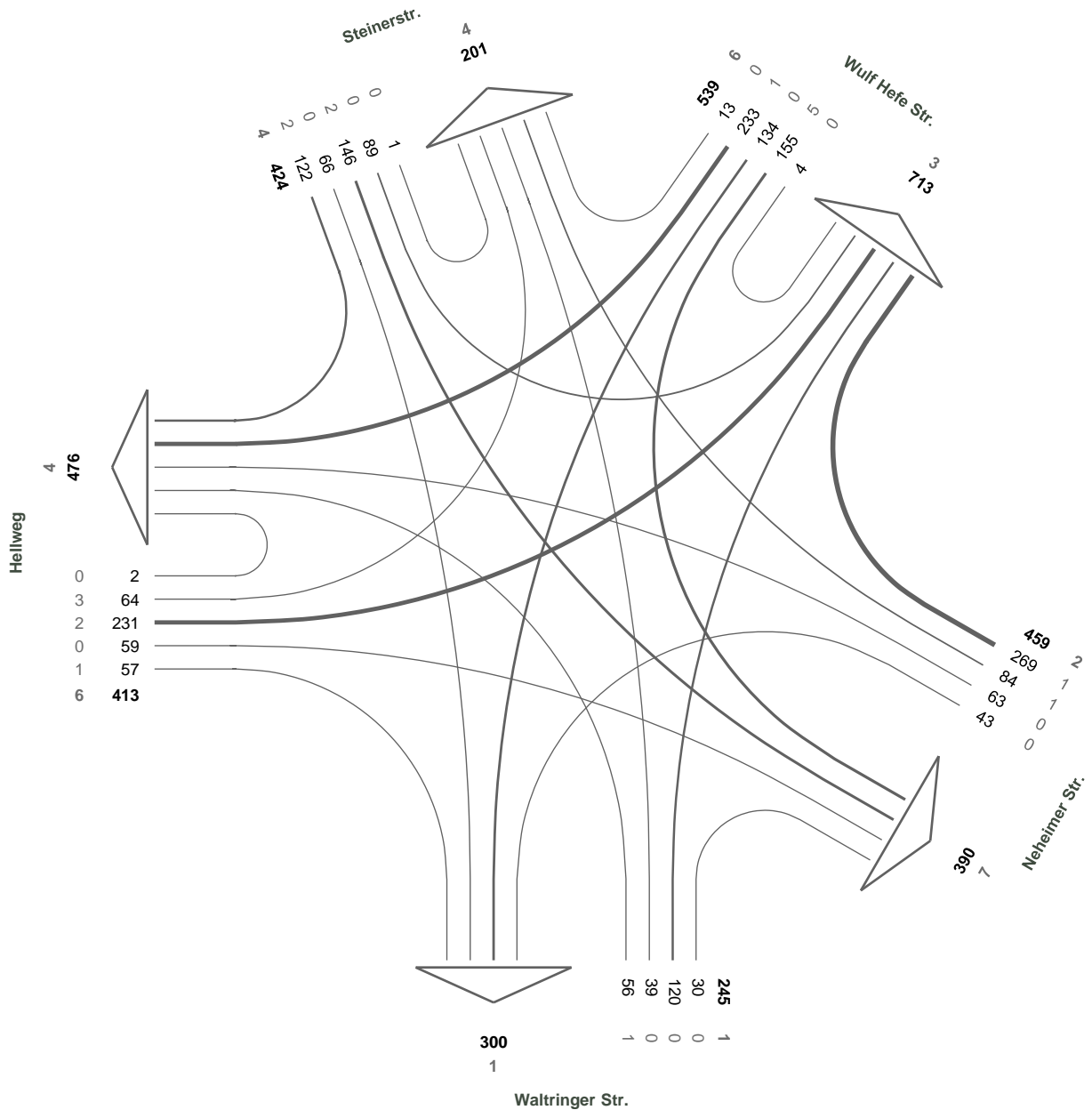

15 - KV Hellweg / Waltringer Str. / Wulf Hefe Str.

28.11.2017
15:00 - 19:00 Uhr
4-h-Block
Kfz (SV)

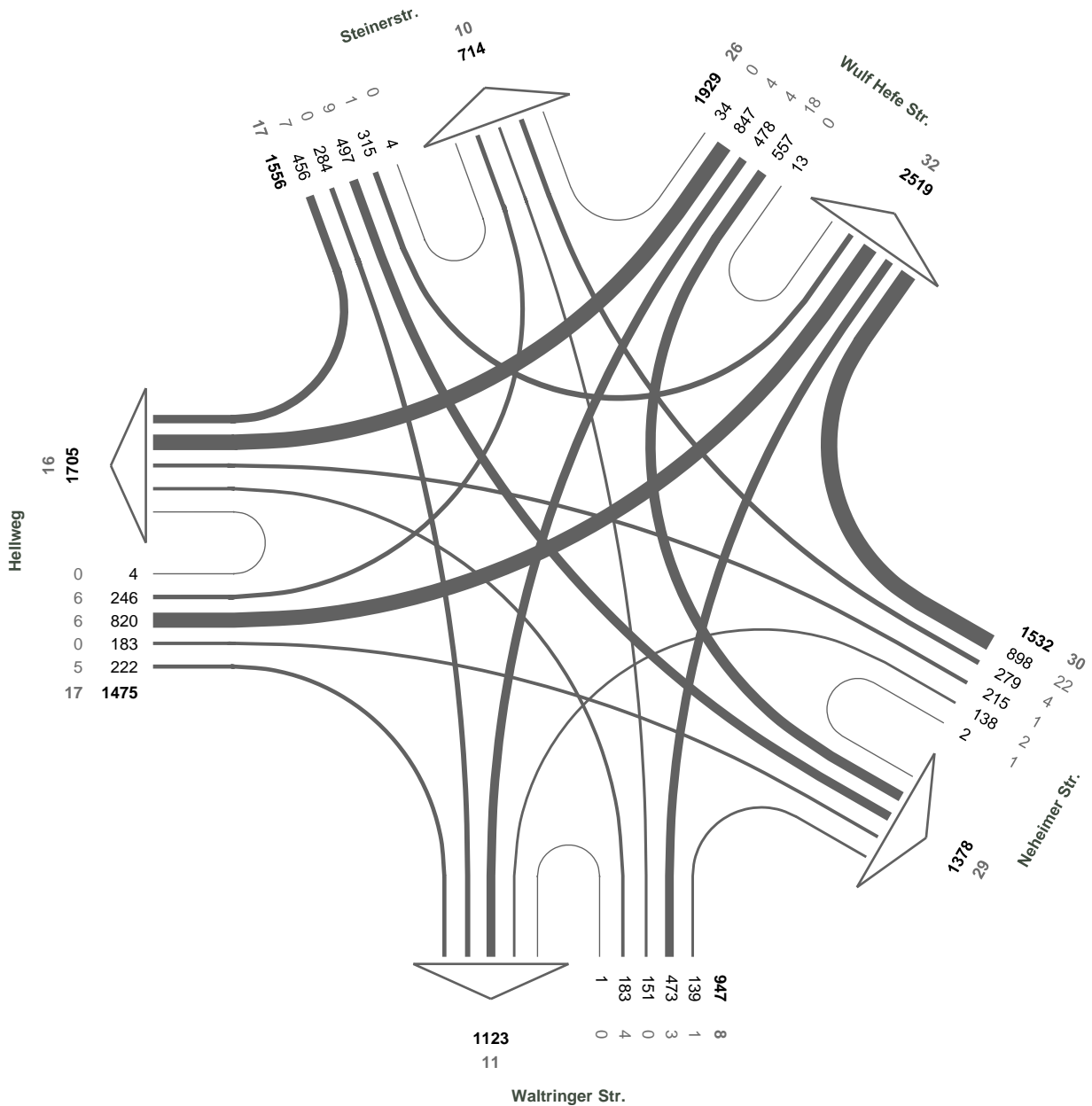

16 - Soester Str. / Hedwig-Dransfeld-Str.

28.11.2017
07:15 - 08:15 Uhr
Morgenspitze
Kfz (SV)

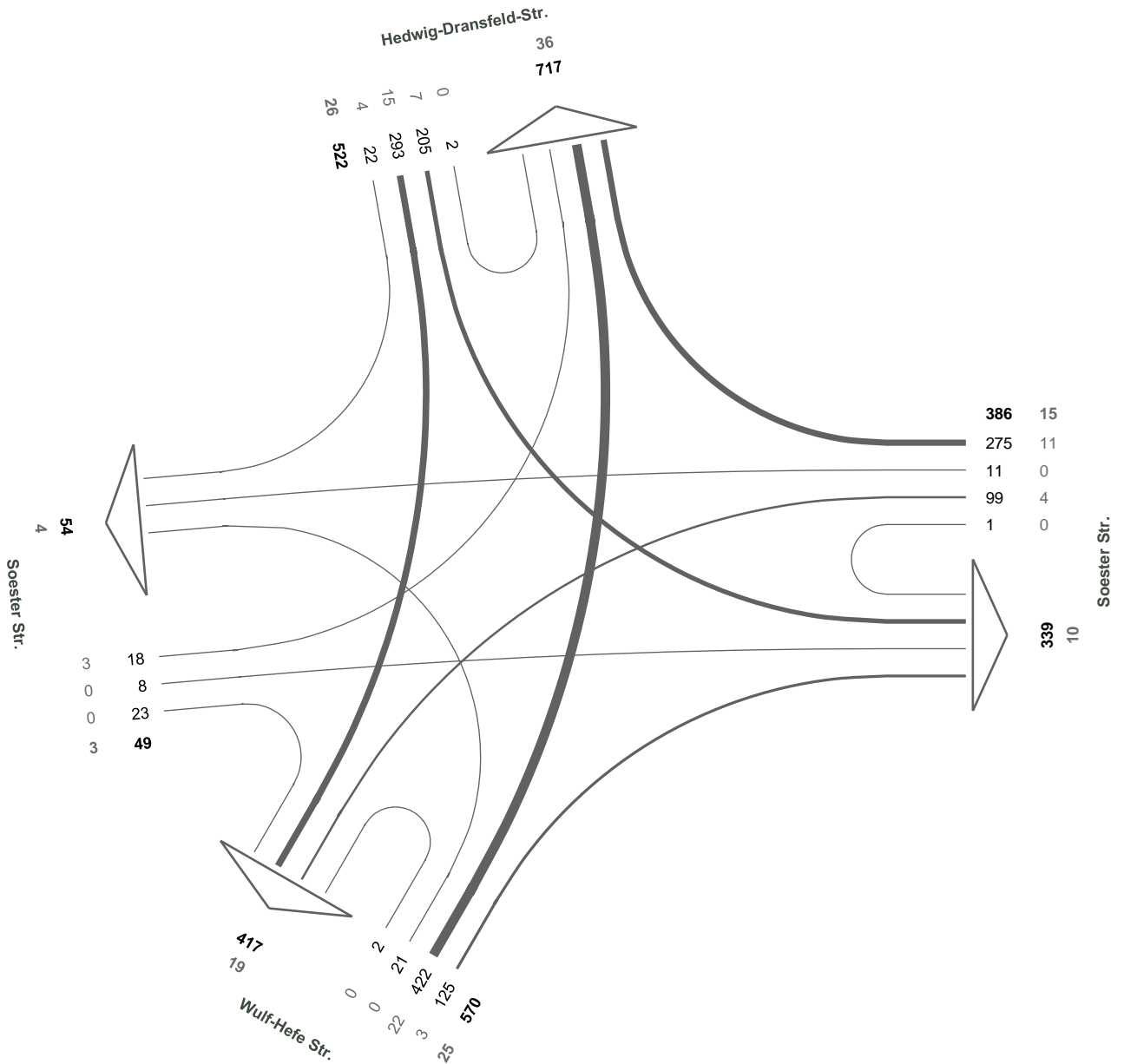

16 - Soester Str. / Hedwig-Dransfeld-Str.

28.11.2017
06:00 - 10:00 Uhr
4-h-Block
Kfz (SV)

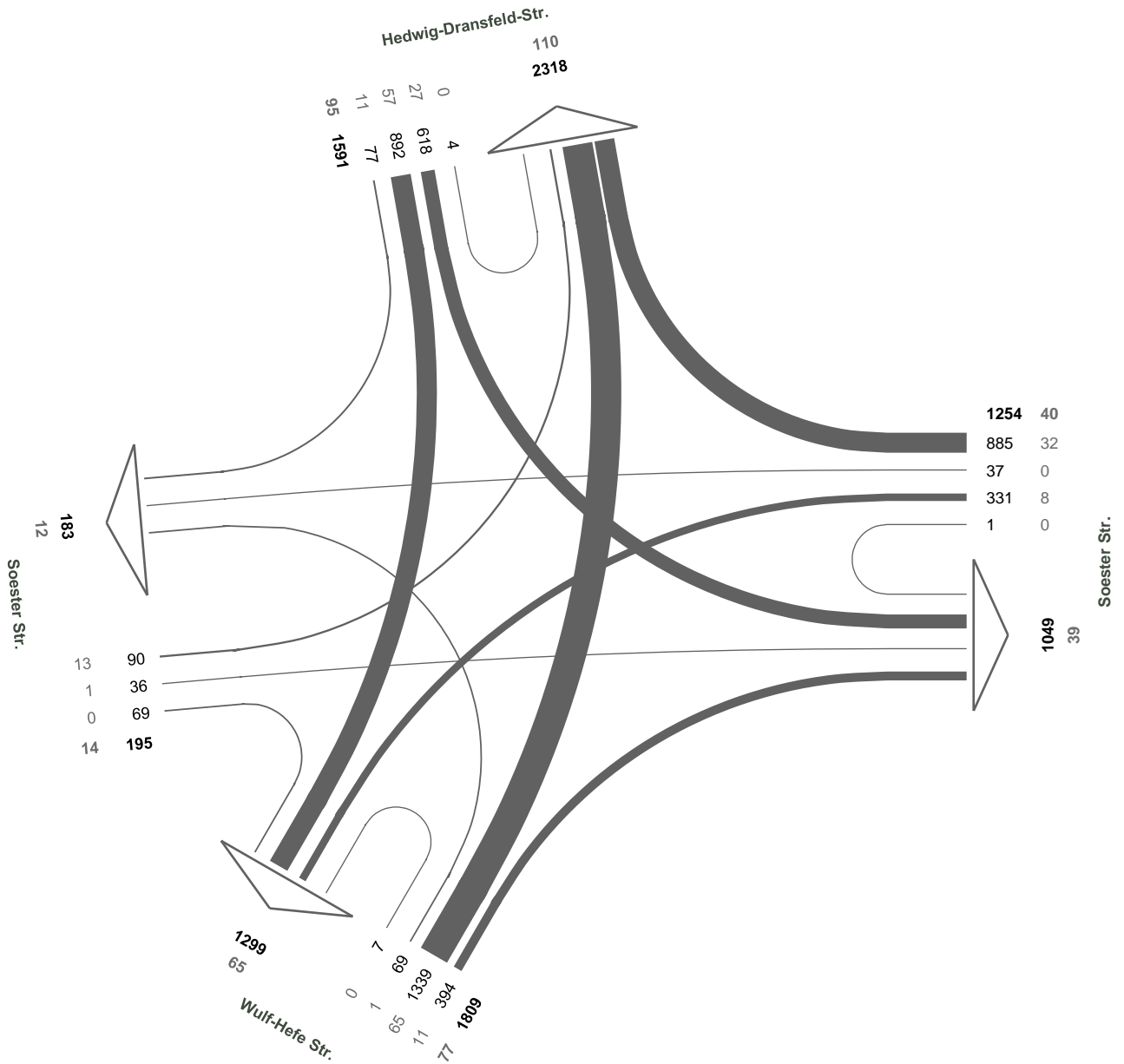

16 - Soester Str. / Hedwig-Dransfeld-Str.

28.11.2017
15:00 - 19:00 Uhr
4-h-Block
Kfz (SV)

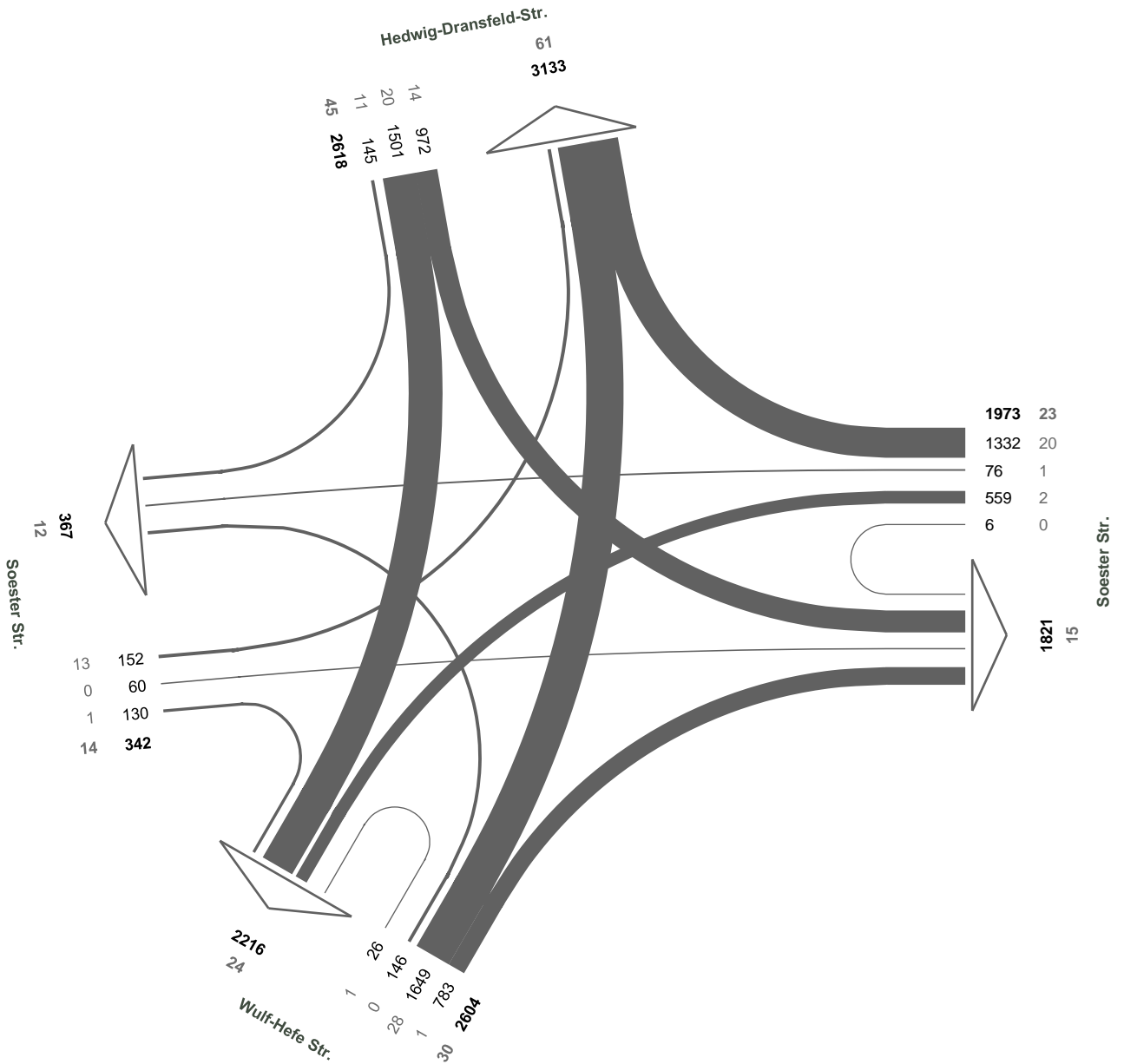

17 - Hellweg / Wickeder Str. / Sankt Georg Str.

28.11.2017
07:15 - 08:15 Uhr
Morgenspitze
Kfz (SV)

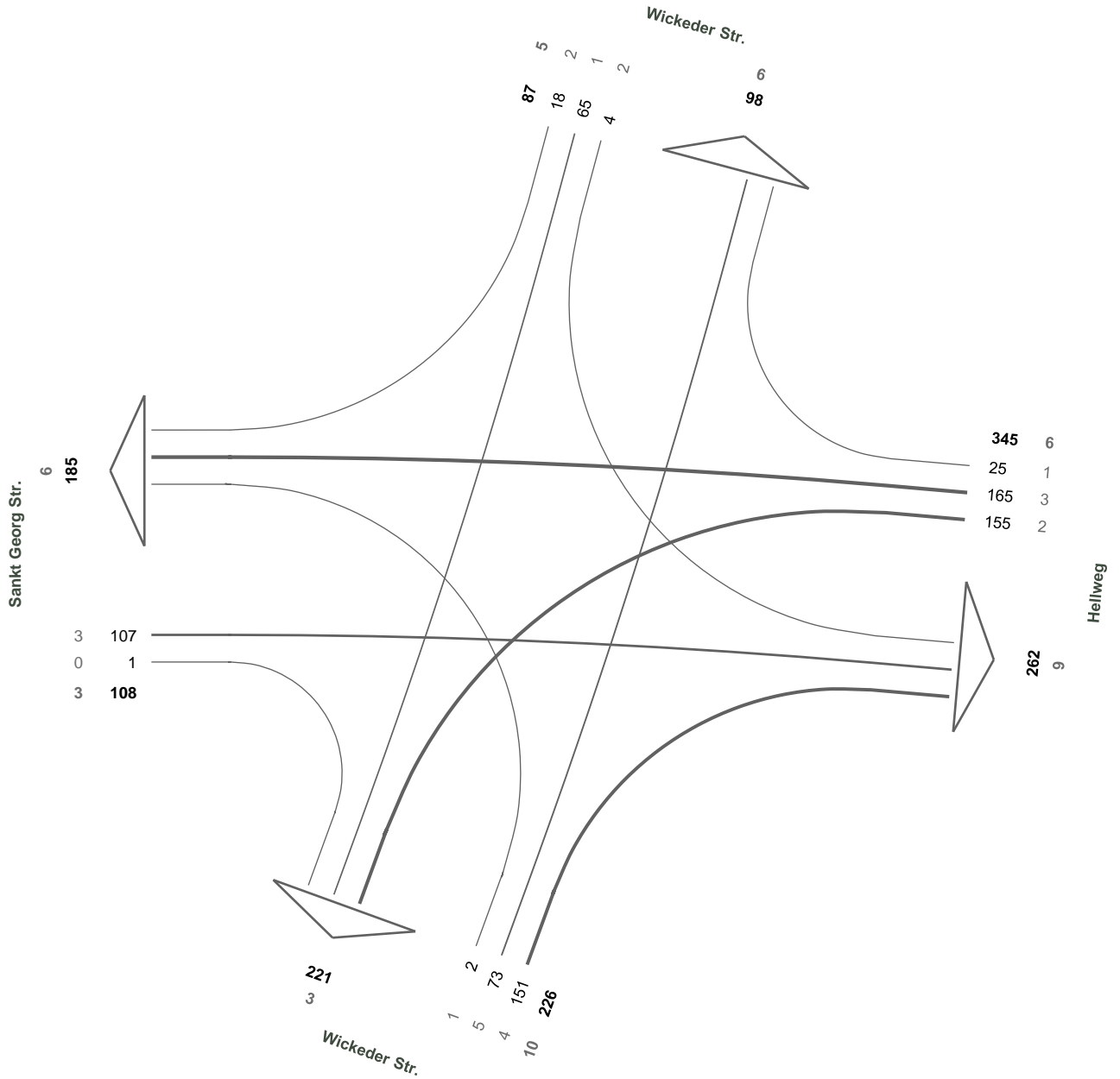

17 - Hellweg / Wickeder Str. / Sankt Georg Str.

28.11.2017
06:00 - 10:00 Uhr
4-h-Block
Kfz (SV)

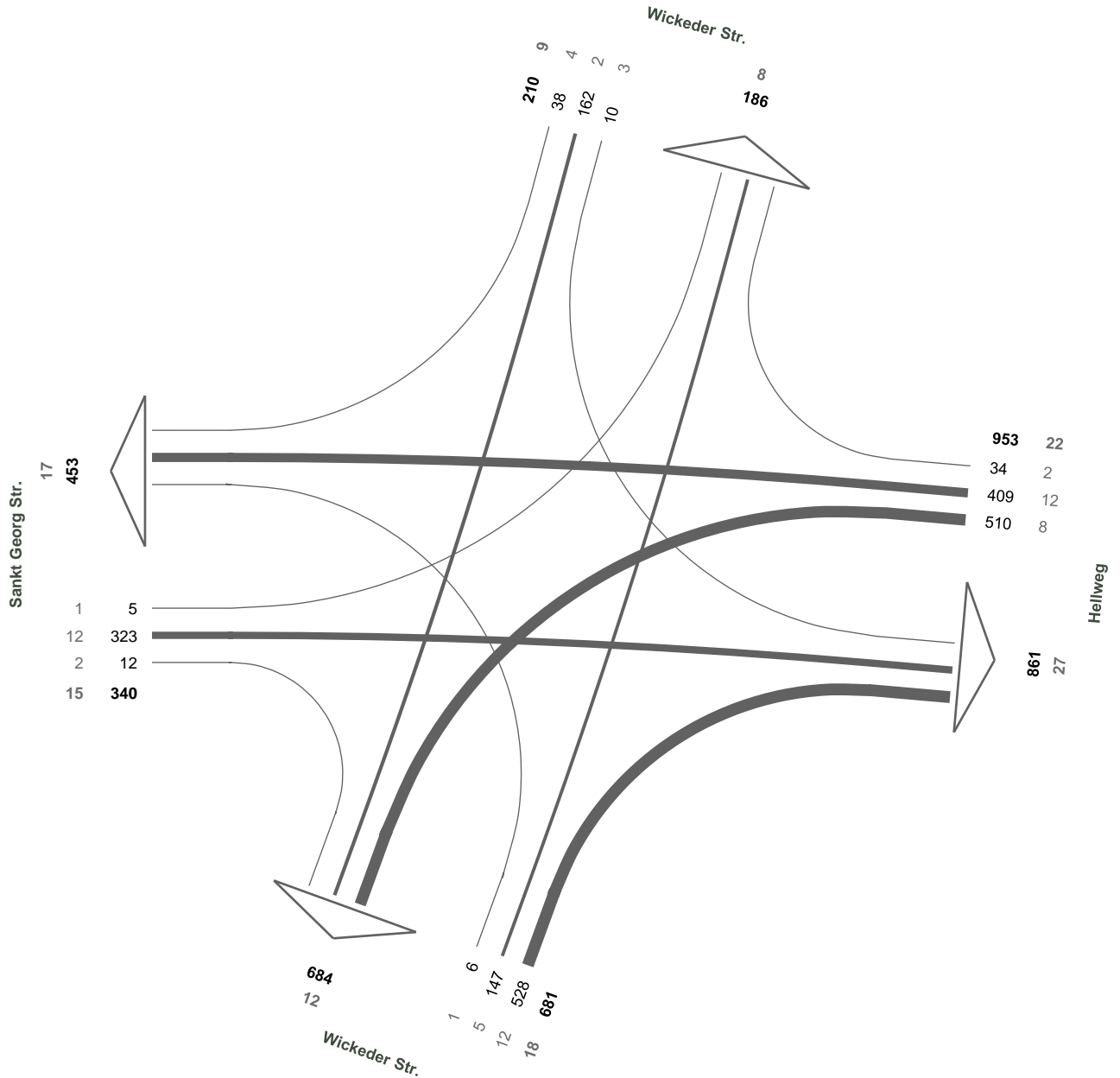

17 - Hellweg / Wickeder Str. / Sankt Georg Str.

28.11.2017
15:30 - 16:30 Uhr
Abendspitze
Kfz (SV)

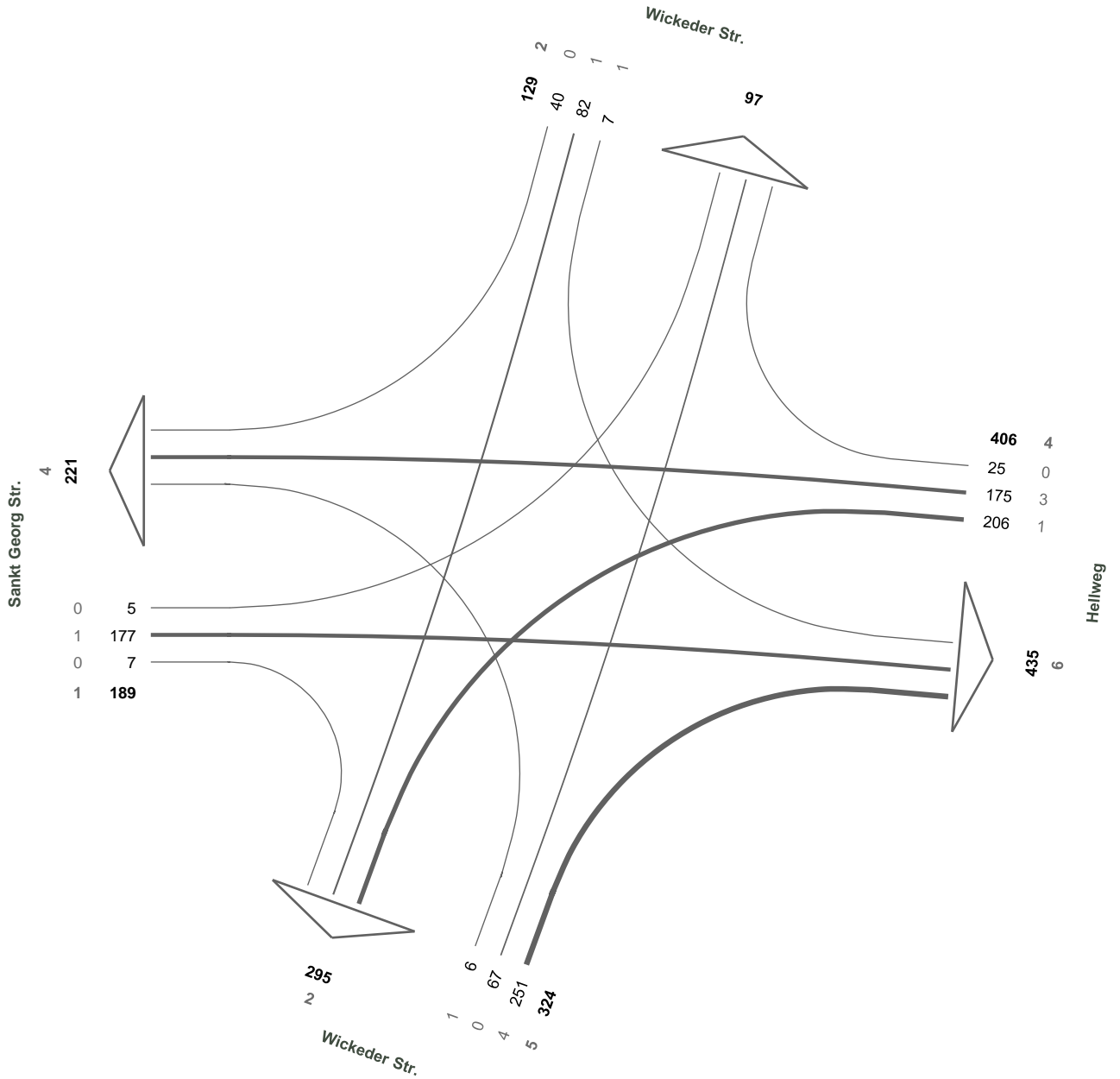

17 - Hellweg / Wickeder Str. / Sankt Georg Str.

28.11.2017
15:00 - 19:00 Uhr
4-h-Block
Kfz (SV)

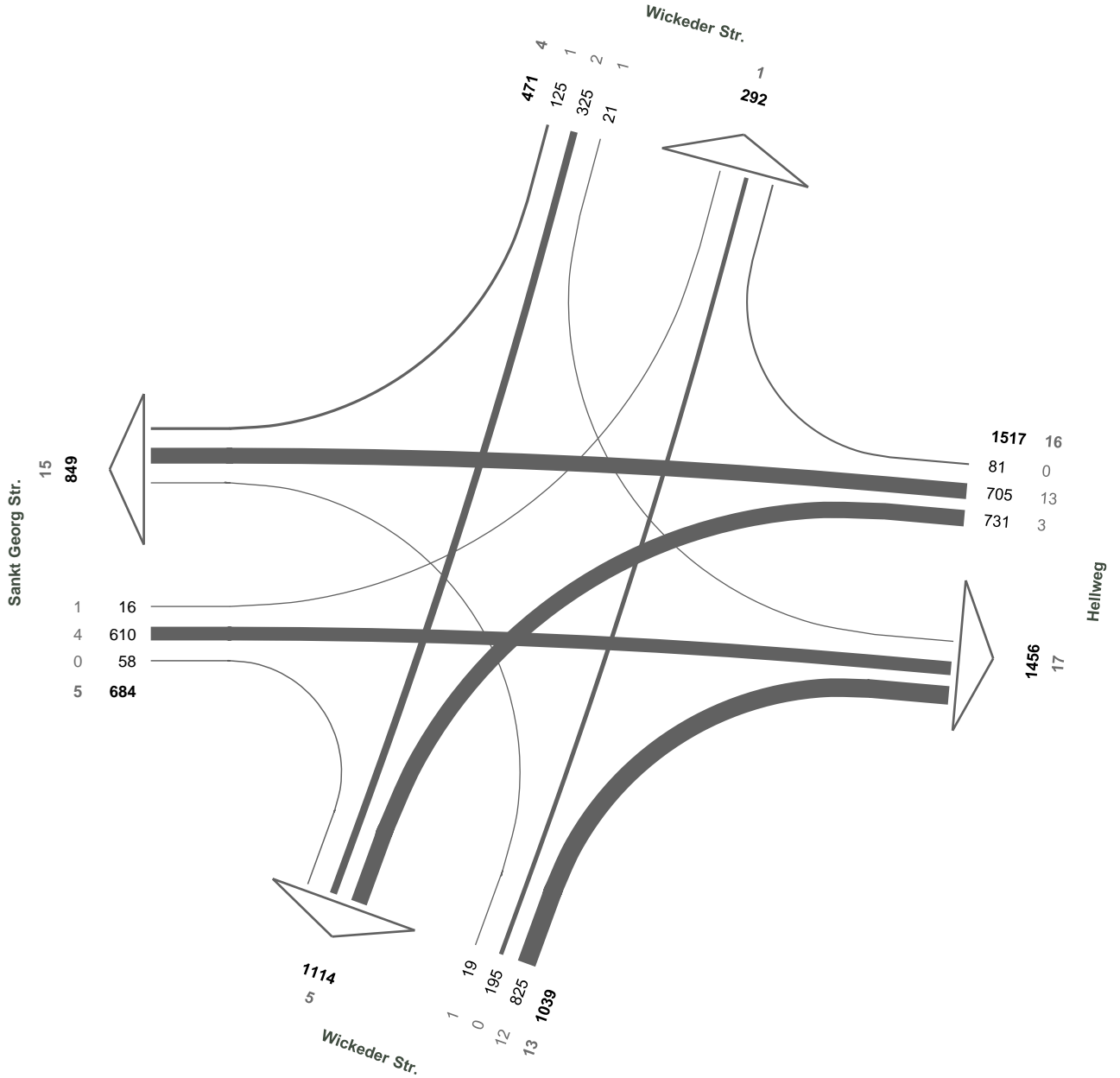

18 - Wickeder Str. / Kurfürstenring

28.11.2017
07:15 - 08:15 Uhr
Morgenspitze
Kfz (SV)

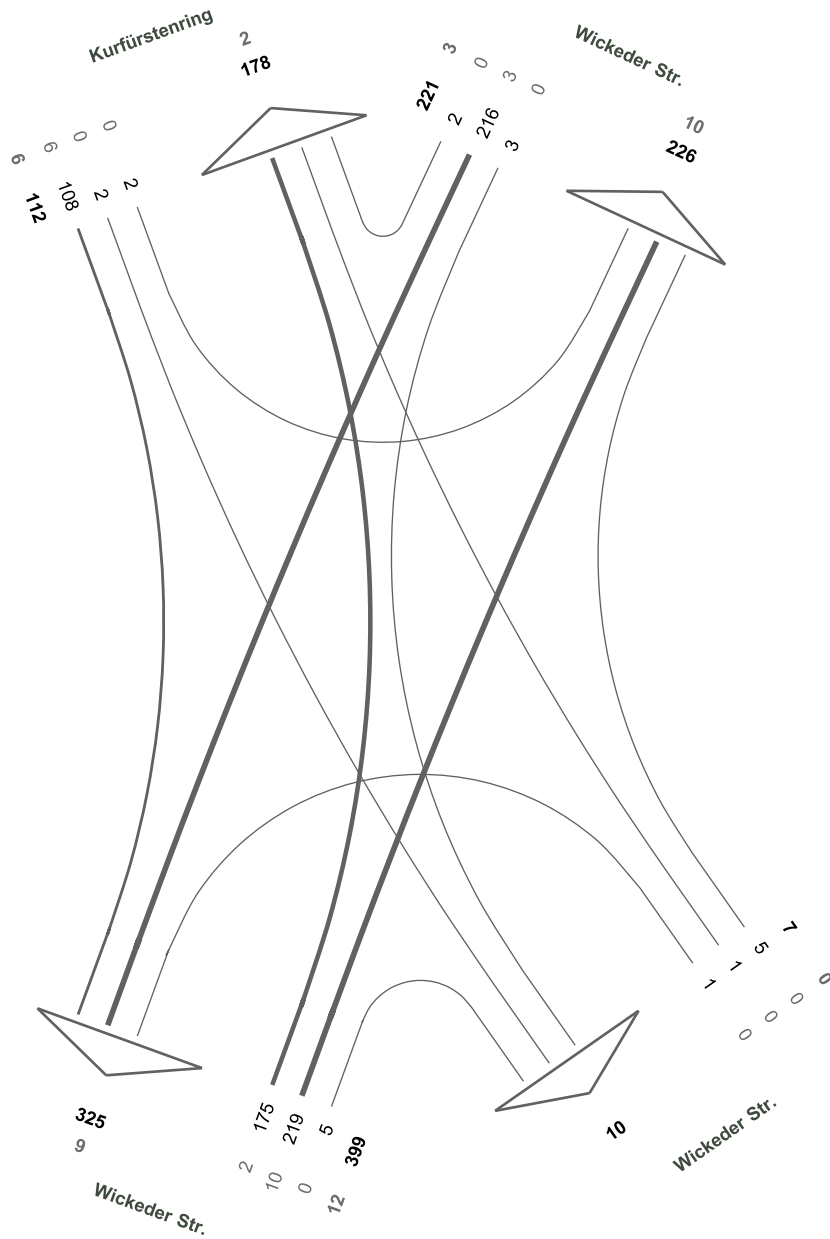

18 - Wickeder Str. / Kurfürstenring

28.11.2017
06:00 - 10:00 Uhr
4-h-Block
Kfz (SV)

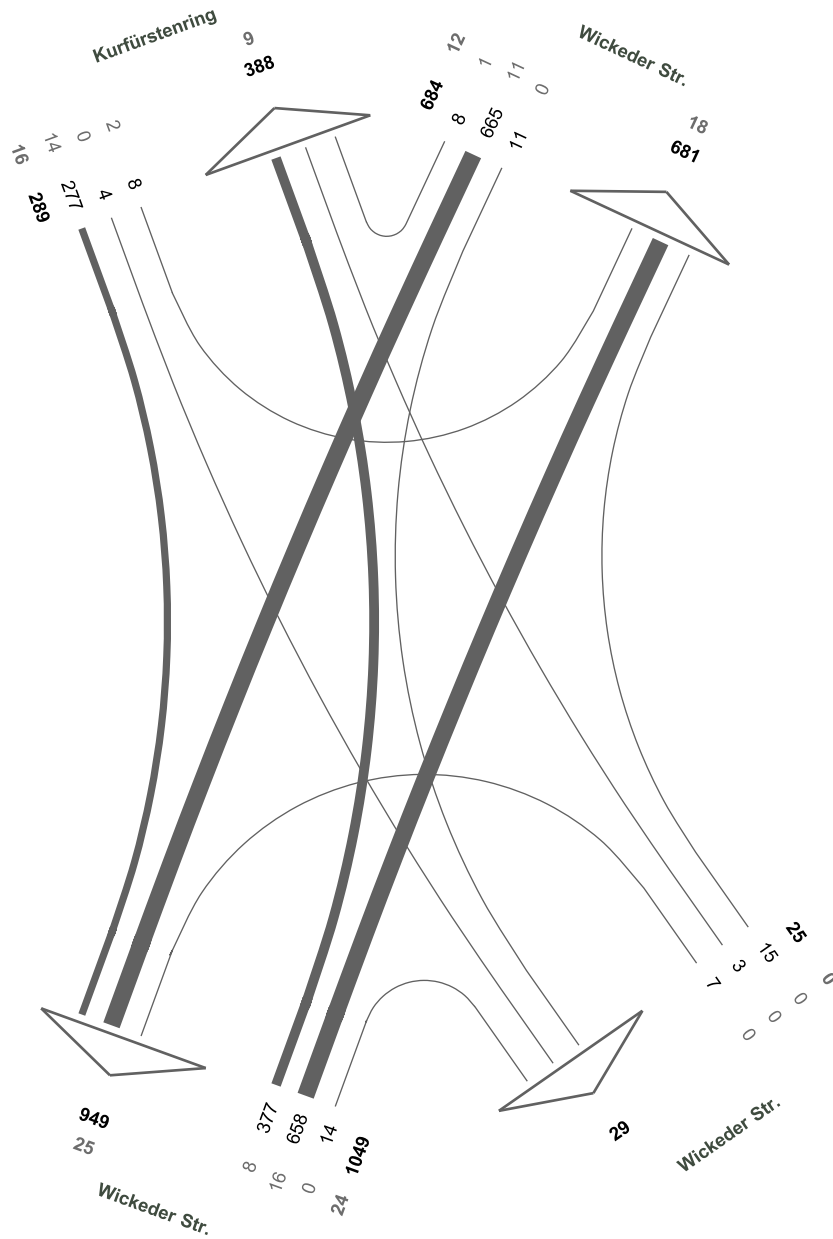

18 - Wickeder Str. / Kurfürstenring

28.11.2017
15:45 - 16:45 Uhr
Abendspitze
Kfz (SV)

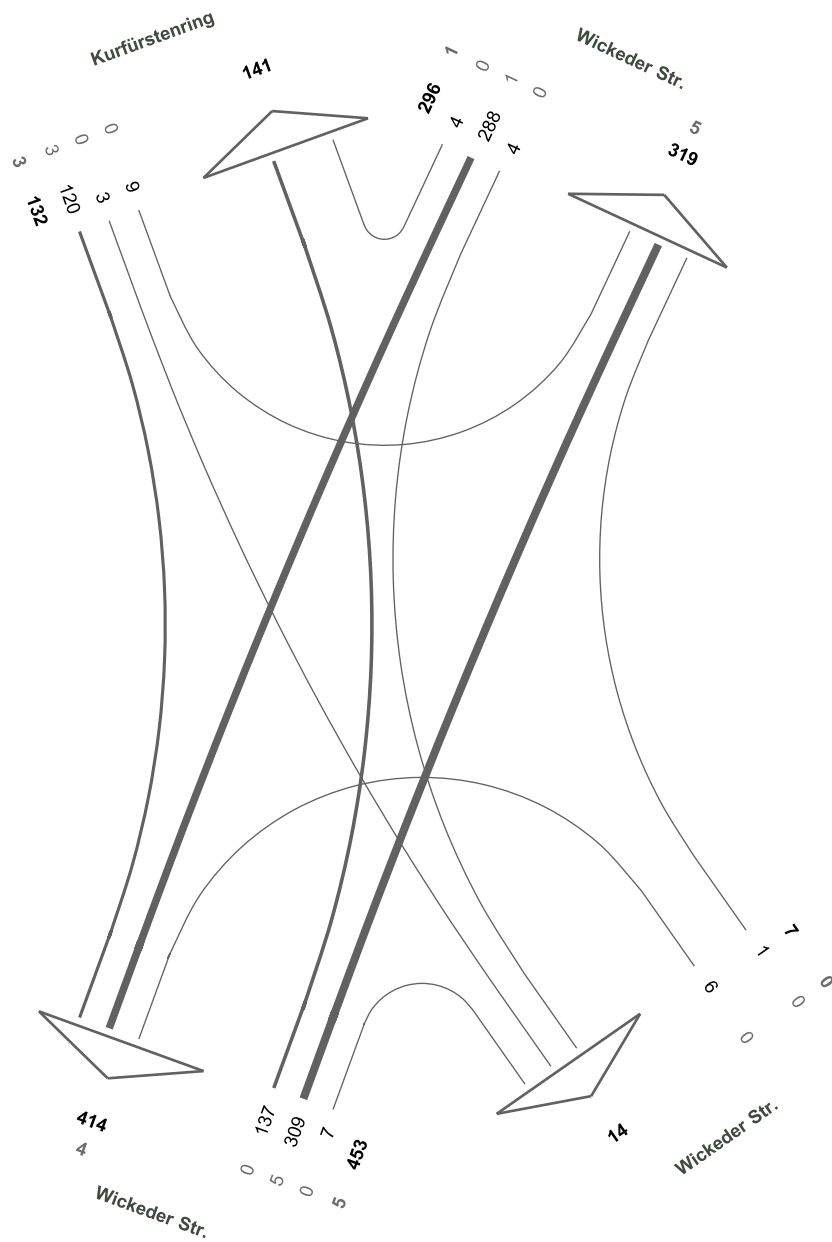

18 - Wickeder Str. / Kurfürstenring

28.11.2017
15:00 - 19:00 Uhr
4-h-Block
Kfz (SV)

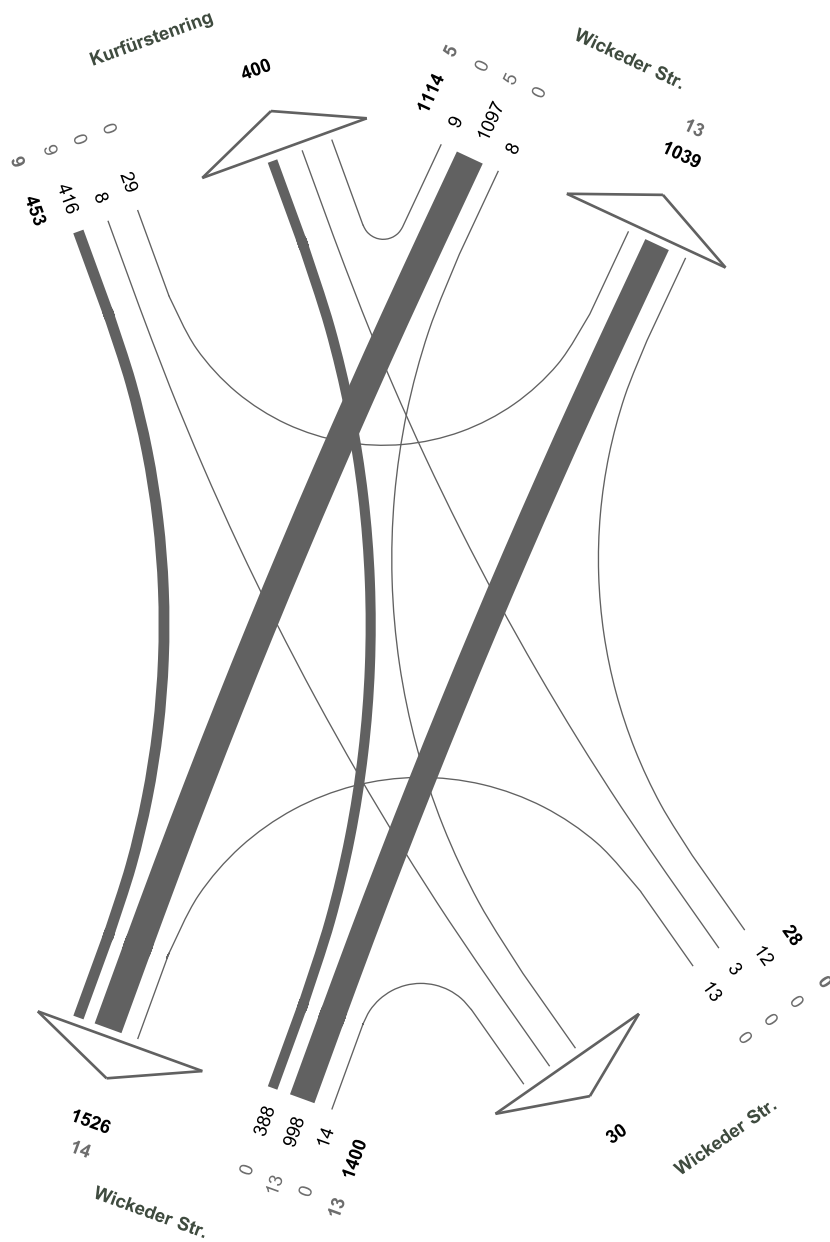

19 - Unnaer Str. / Lindenallee

28.11.2017
07:15 - 08:15 Uhr
Morgenspitze
Kfz (SV)

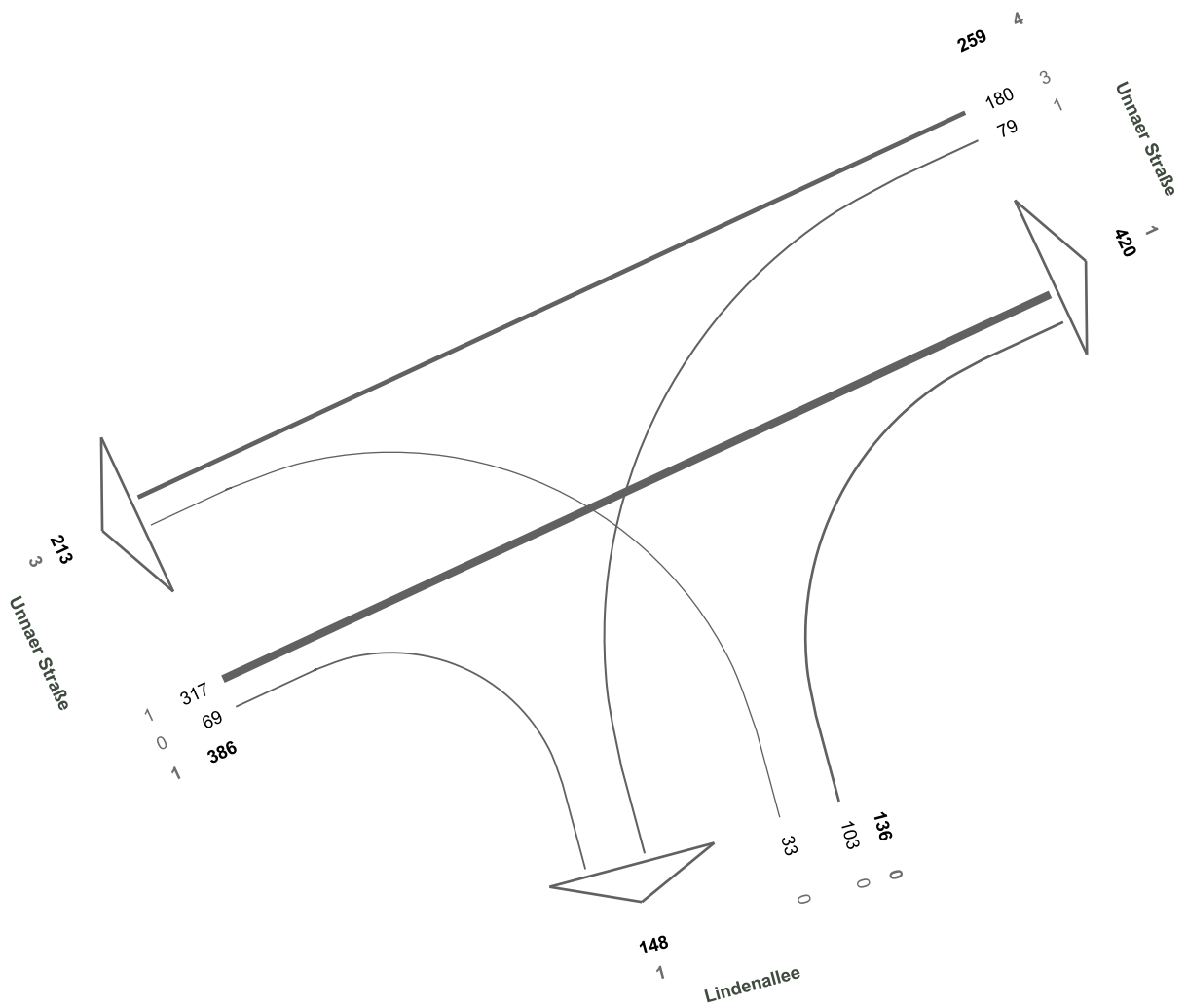

19 - Unnaer Str. / Lindenallee

28.11.2017
06:00 - 10:00 Uhr
4-h-Block
Kfz (SV)

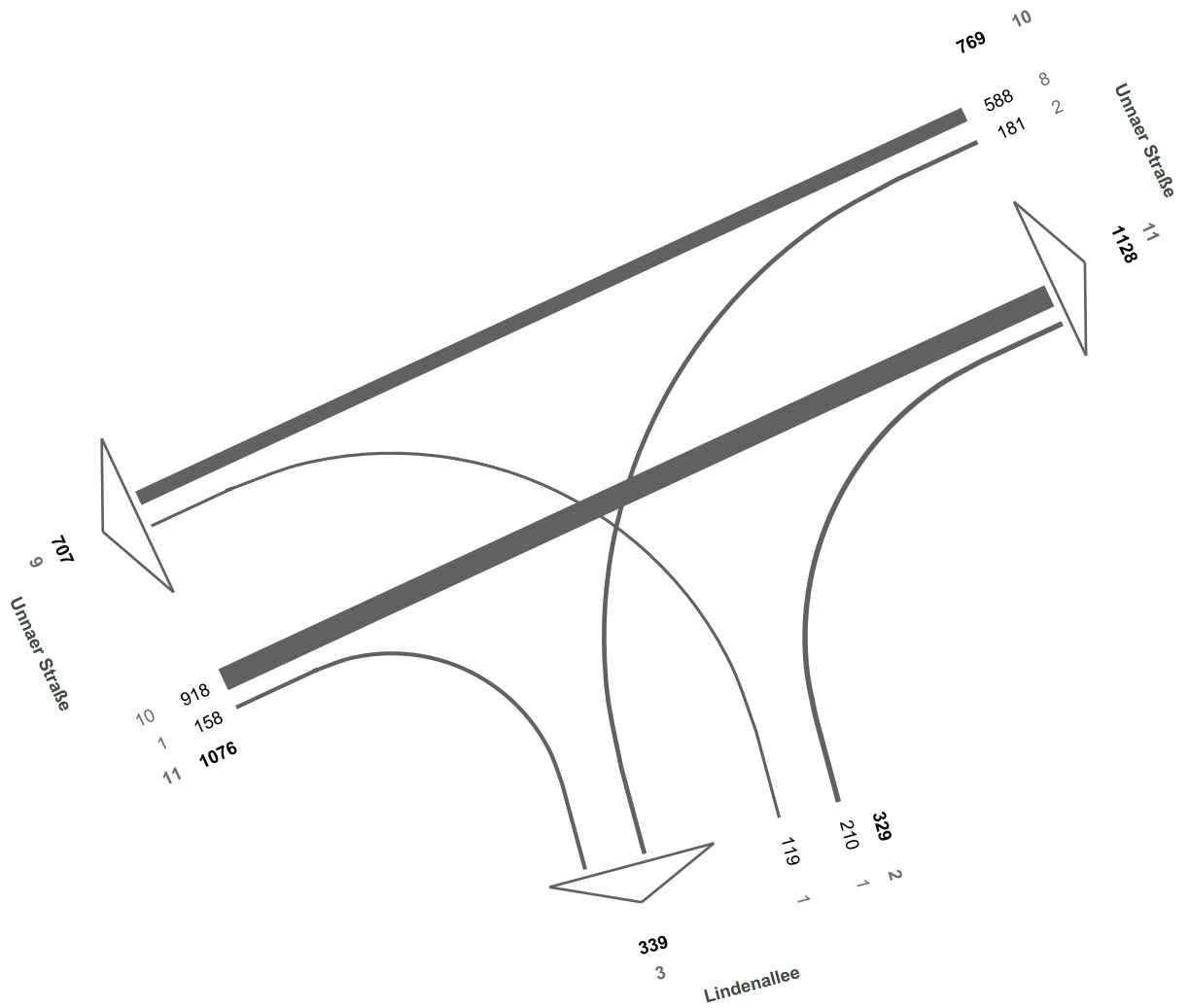

19 - Unnaer Str. / Lindenallee

28.11.2017
15:30 - 16:30 Uhr
Abendspitze
Kfz (SV)

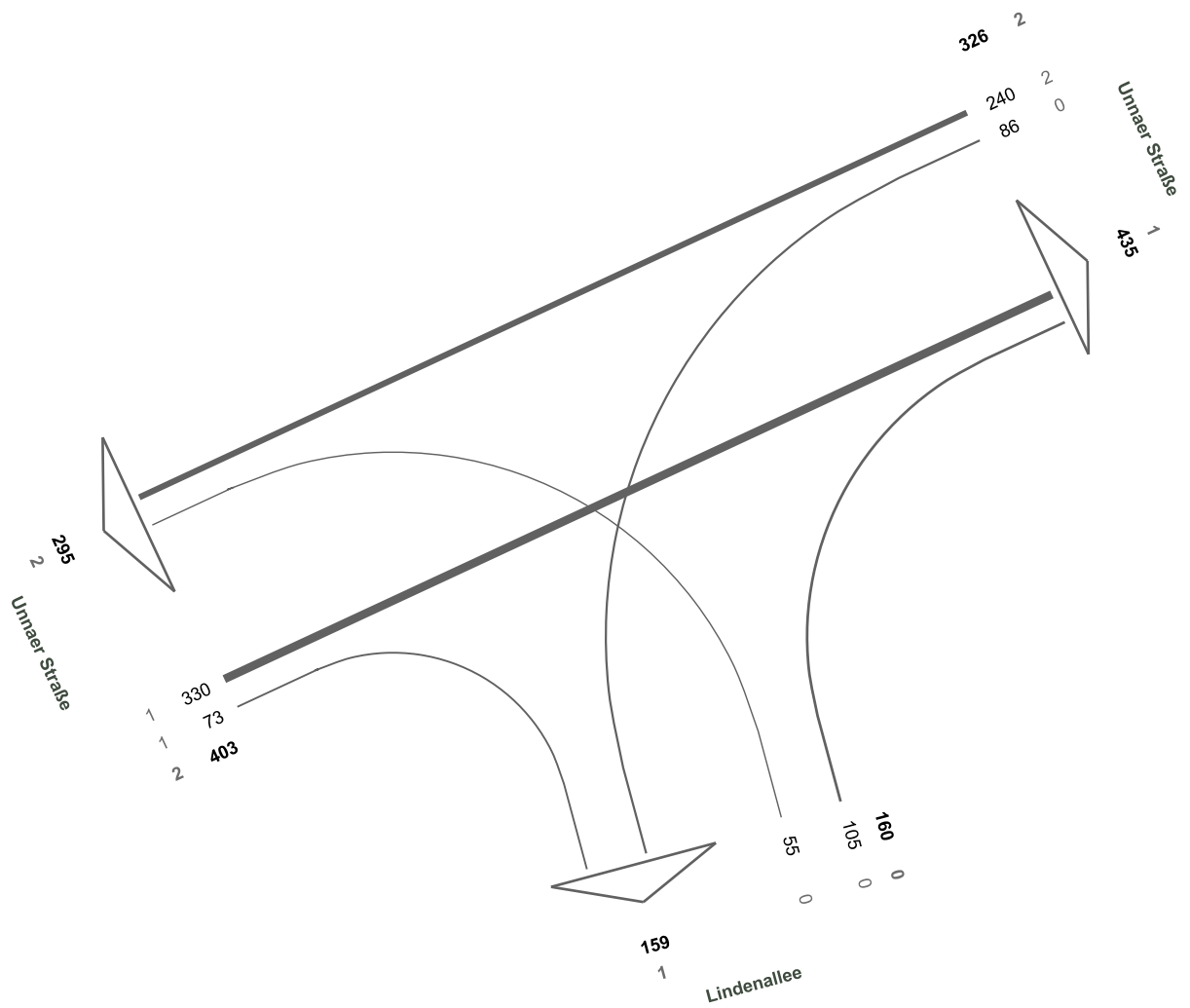

19 - Unnaer Str. / Lindenallee

28.11.2017
15:00 - 19:00 Uhr
4-h-Block
Kfz (SV)

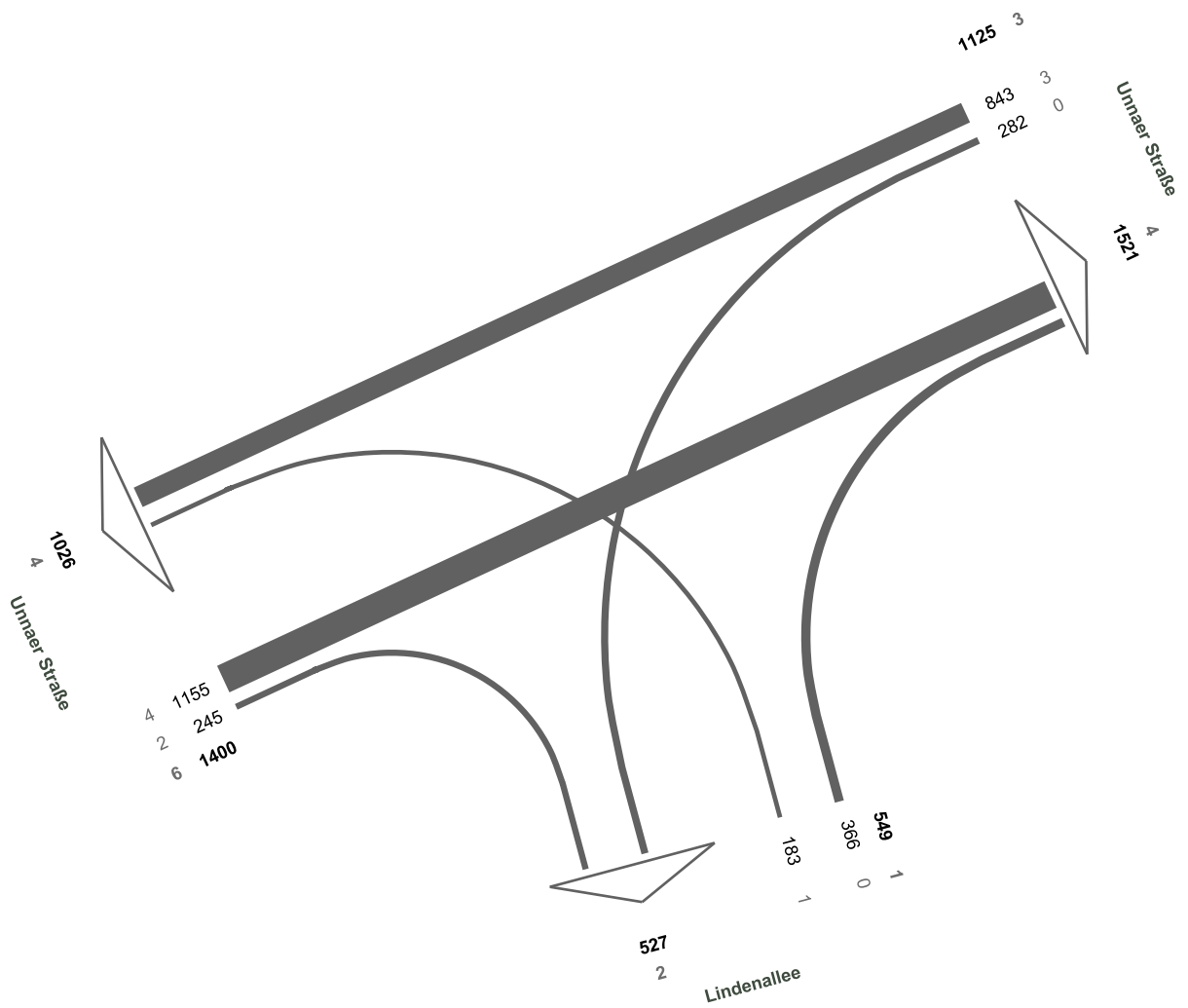

20 - K18 / Budberger Straße

28.11.2017
 07:00 - 08:00 Uhr
 Morgenspitze
 Kfz (SV)

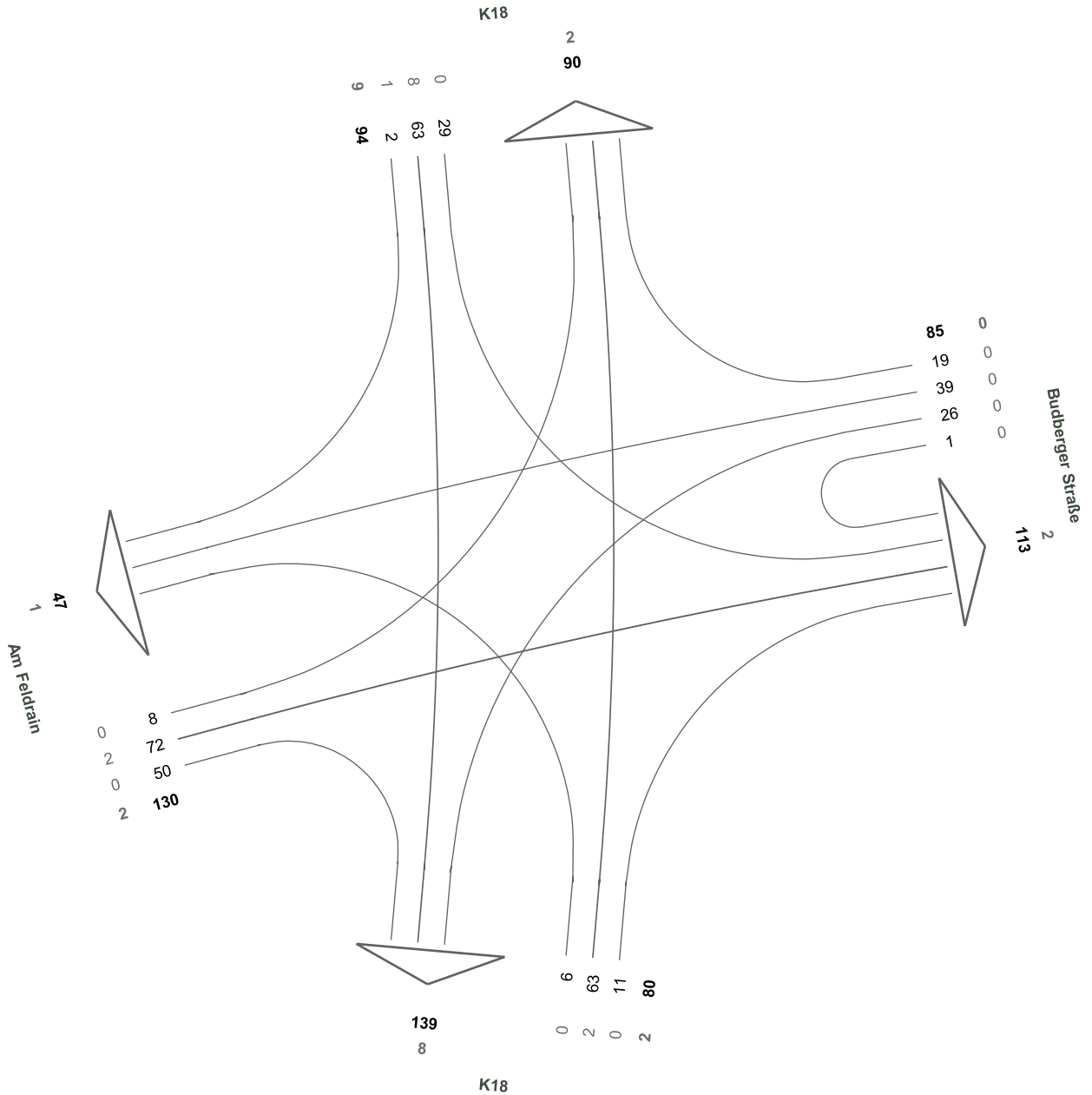

20 - K18 / Budberger Straße

28.11.2017
 06:00 - 10:00 Uhr
 4-h-Block
 Kfz (SV)

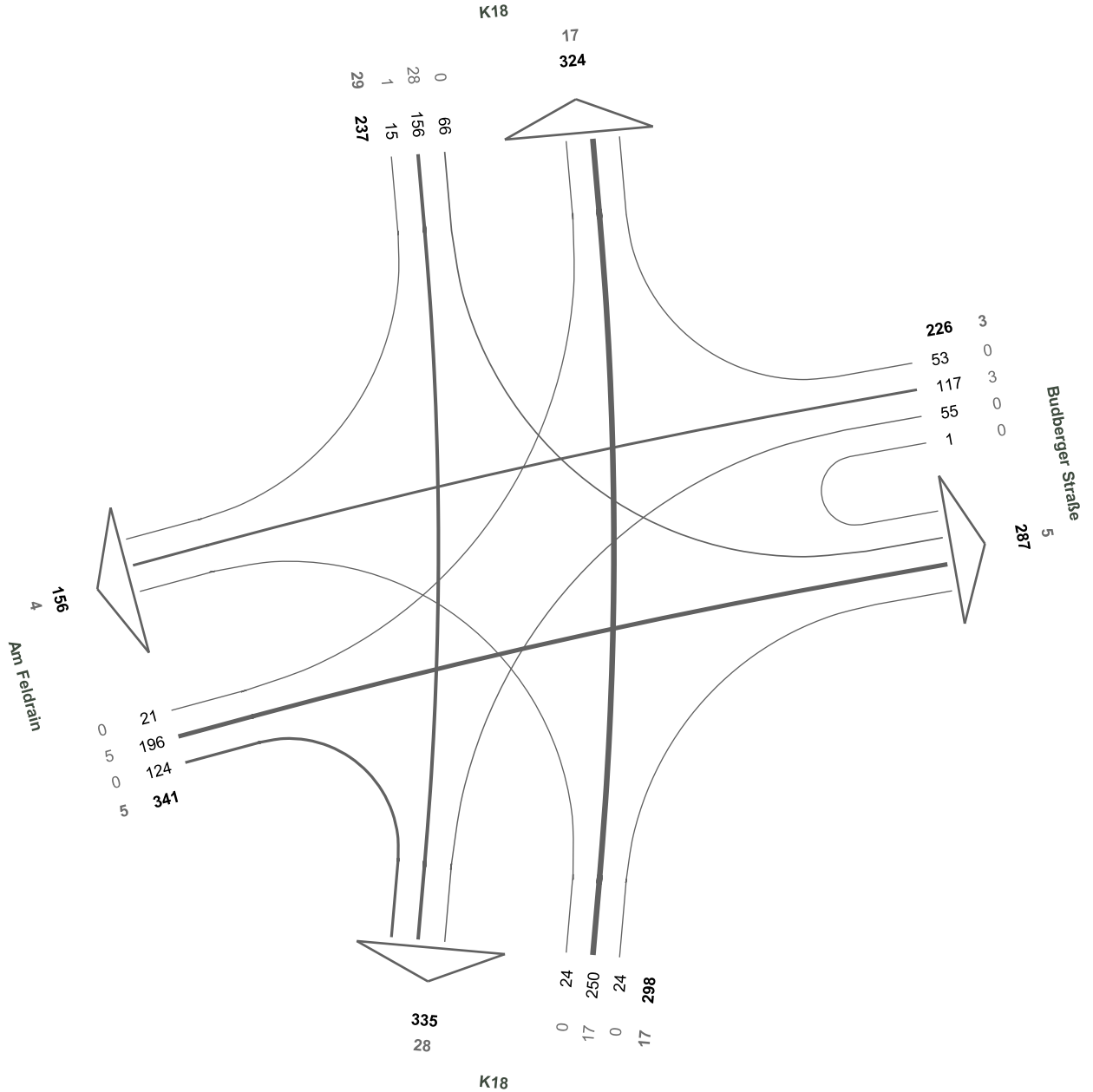

20 - K18 / Budberger Straße

28.11.2017
 15:45 - 16:45 Uhr
 Abendspitze
 Kfz (SV)

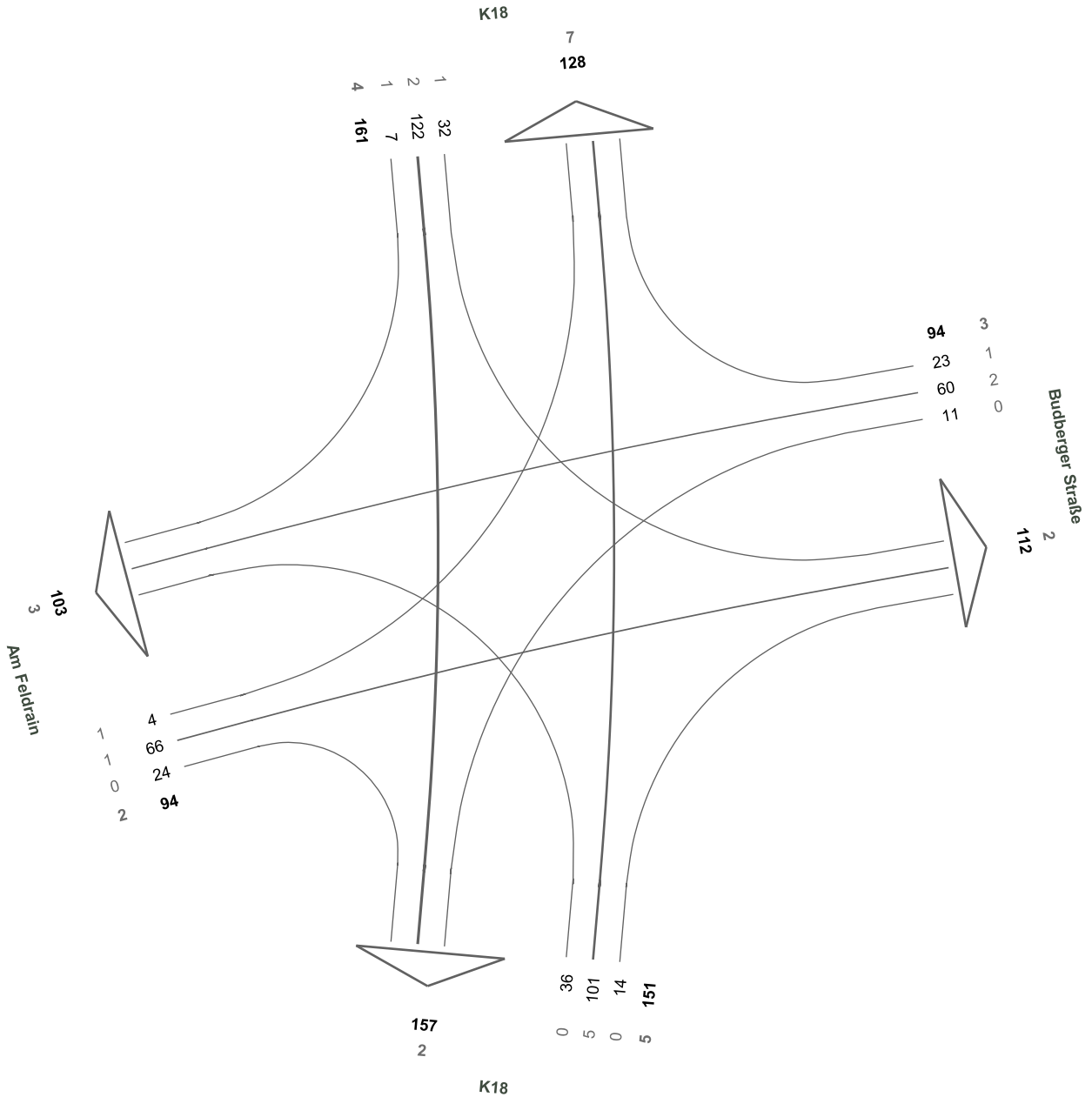

20 - K18 / Budberger Straße

28.11.2017
15:00 - 19:00 Uhr
4-h-Block
Kfz (SV)

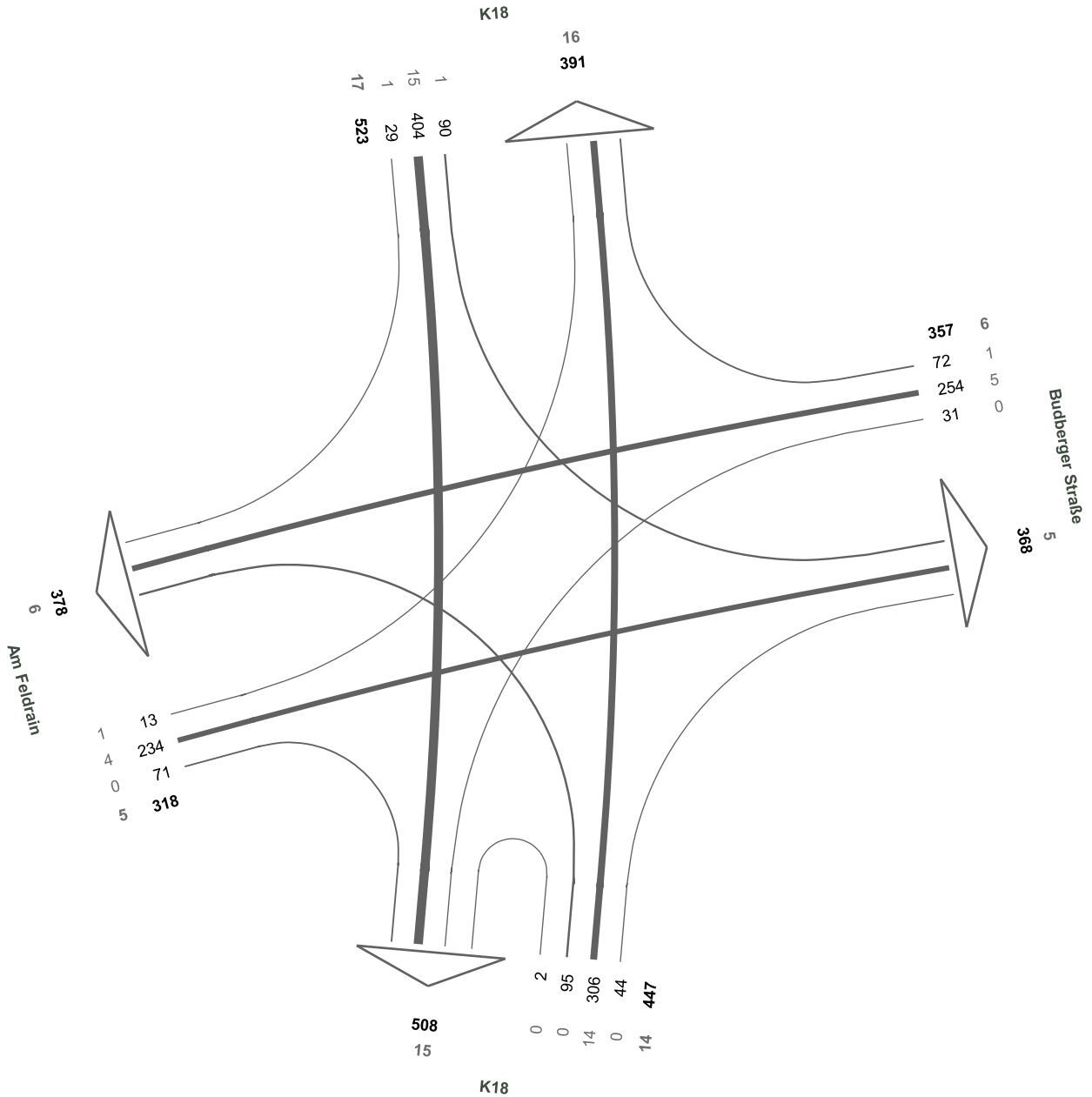

21 - Langenwiedenweg / Olakenweg

28.11.2017
07:15 - 08:15 Uhr
Morgenspitze
Kfz (SV)

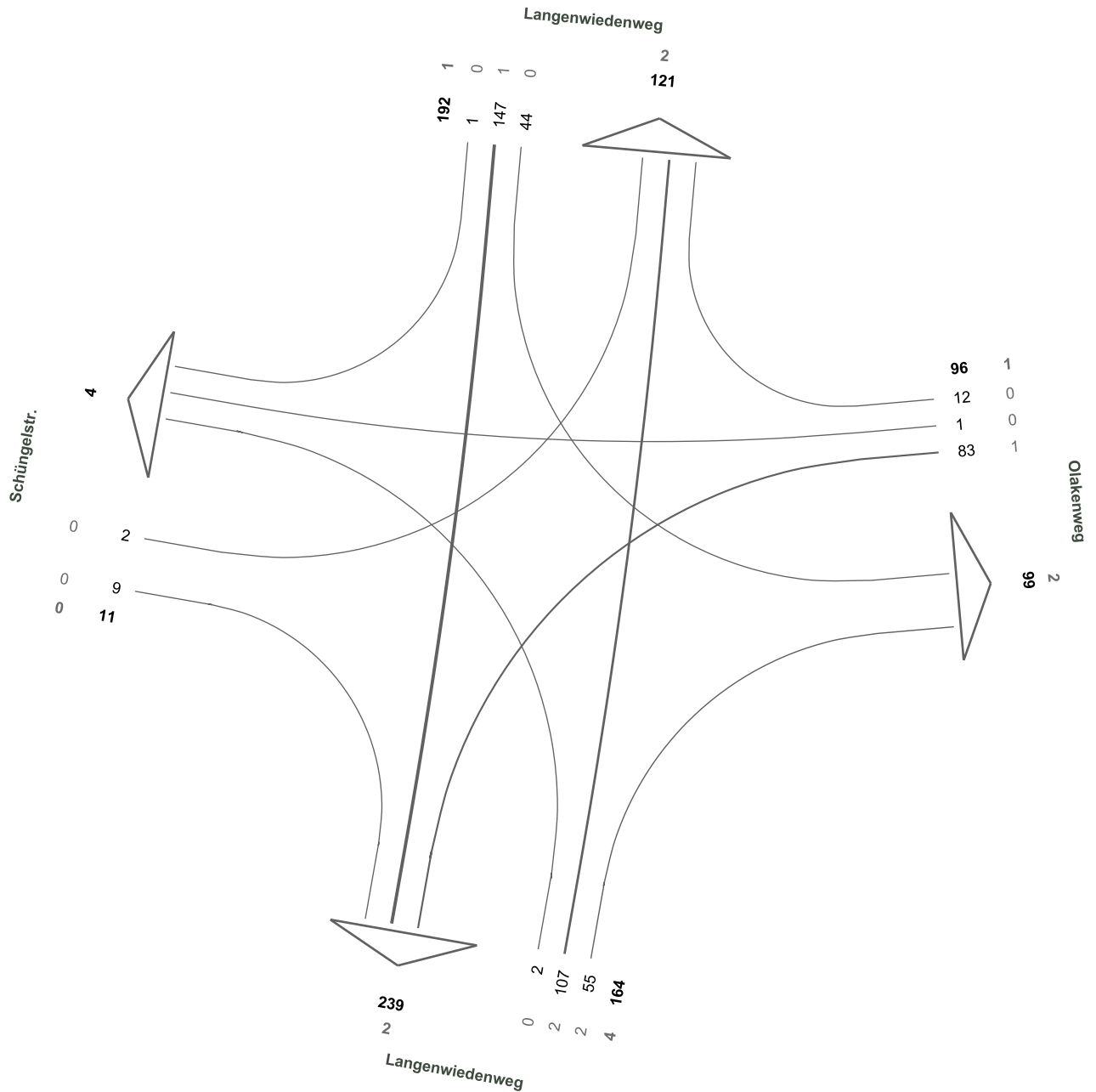

21 - Langenwiedenweg / Olakenweg

28.11.2017
06:00 - 10:00 Uhr
4-h-Block
Kfz (SV)

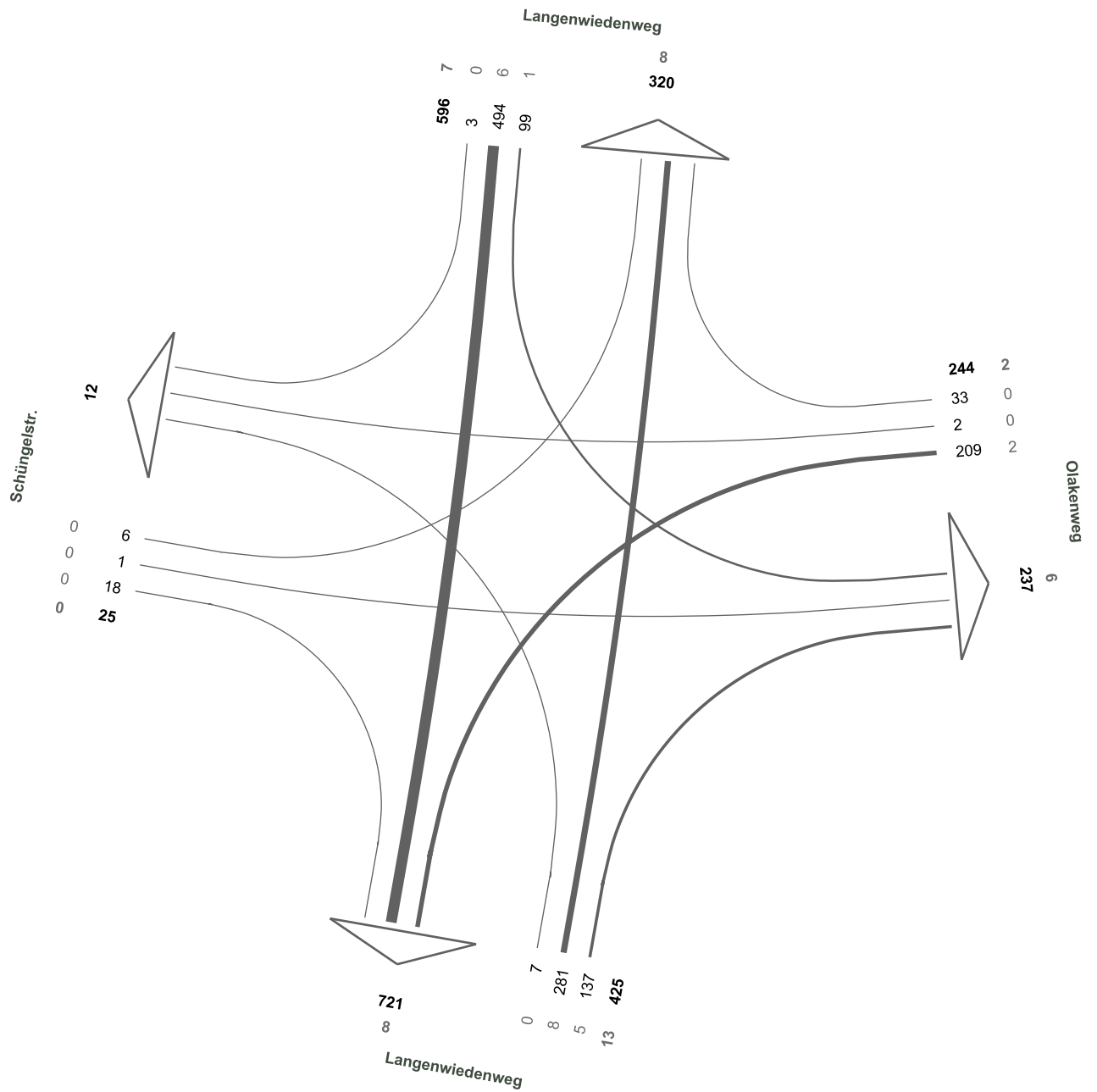

21 - Langenwiedenweg / Olakenweg

28.11.2017
16:00 - 17:00 Uhr
Abendspitze
Kfz (SV)

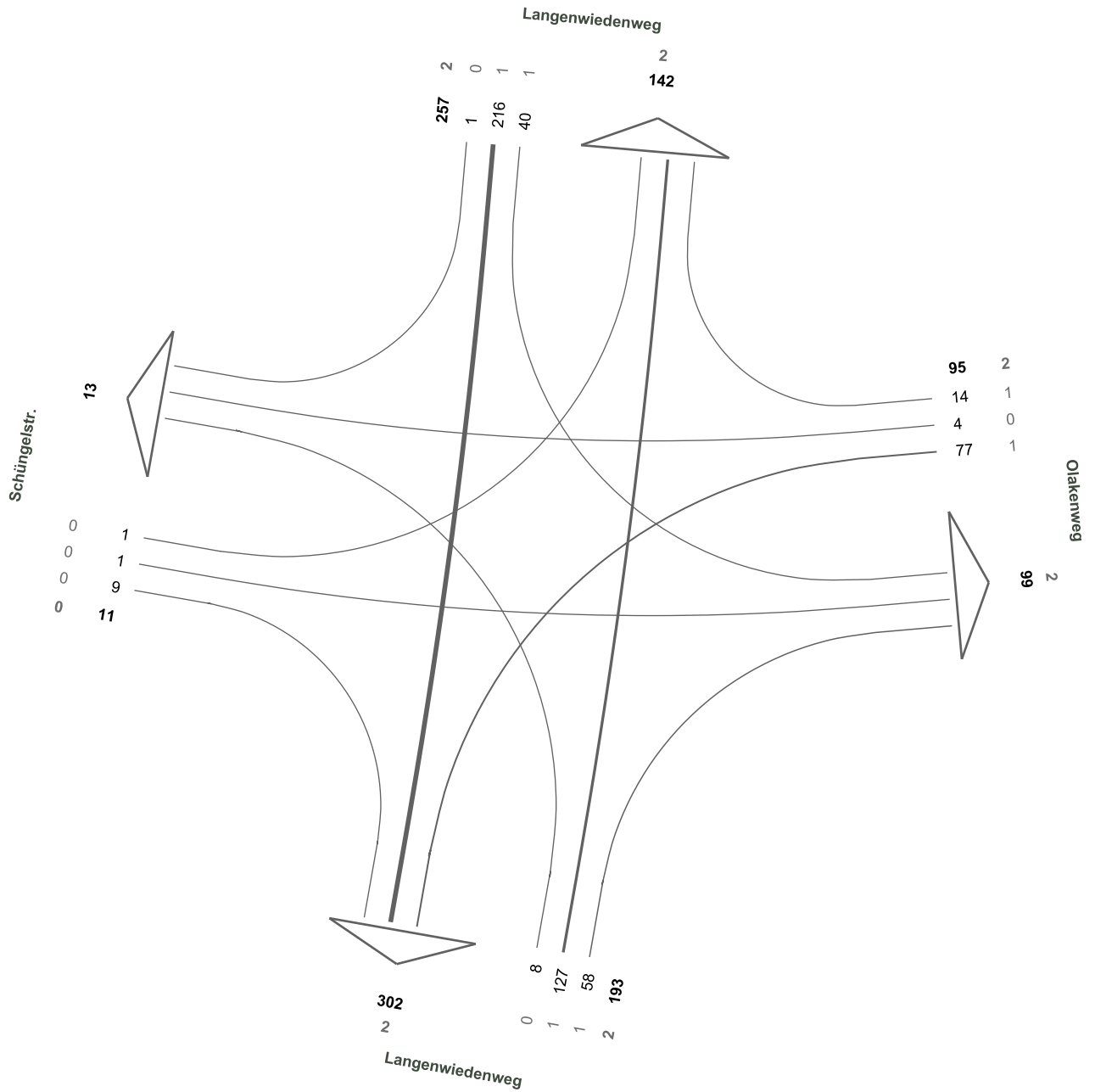

21 - Langenwiedenweg / Olakenweg

28.11.2017
15:00 - 19:00 Uhr
4-h-Block
Kfz (SV)

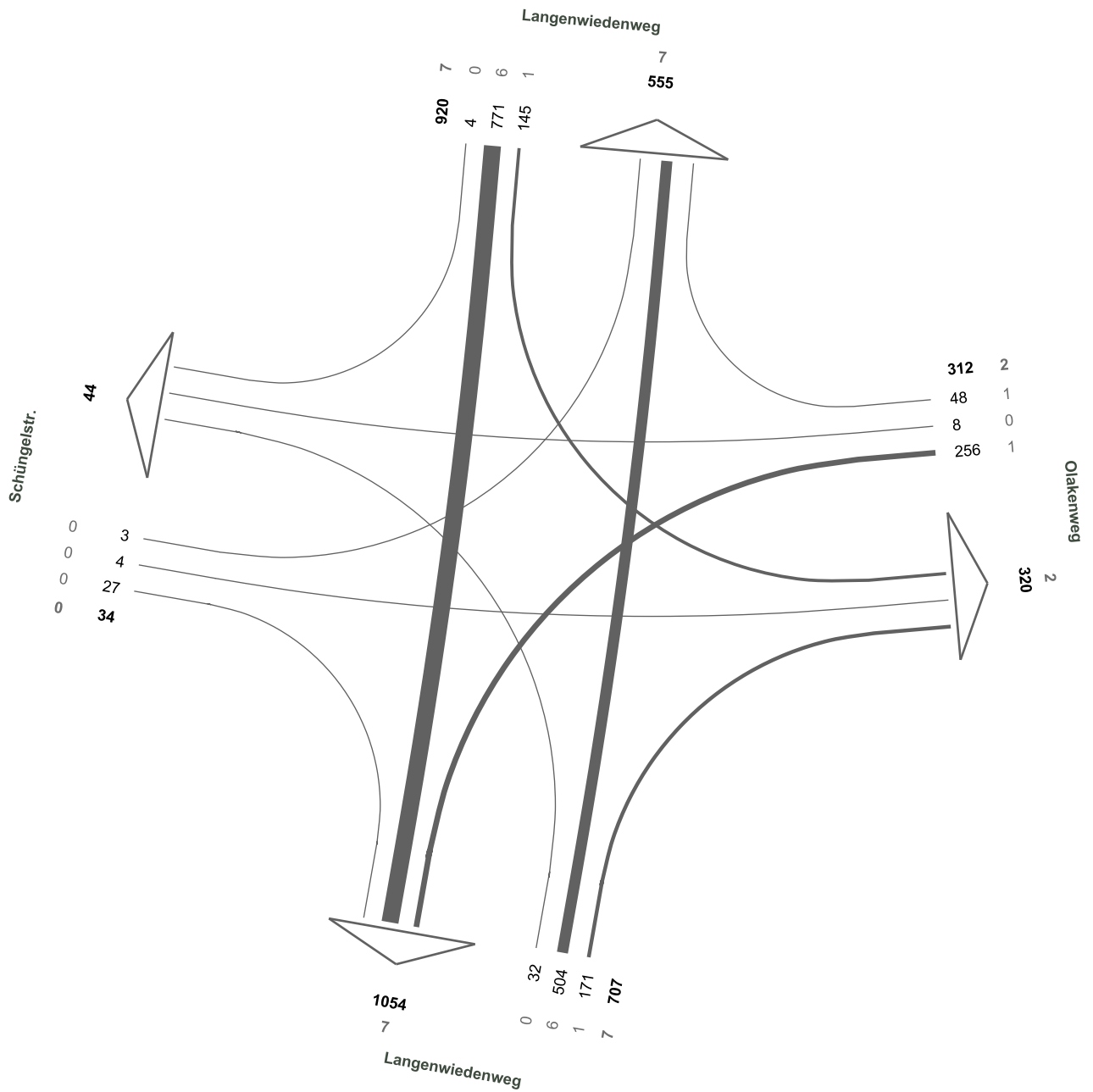

22 - Neuwerk / Auf dem Kreiter

28.11.2017
07:00 - 08:00 Uhr
Morgenspitze
Kfz (SV)

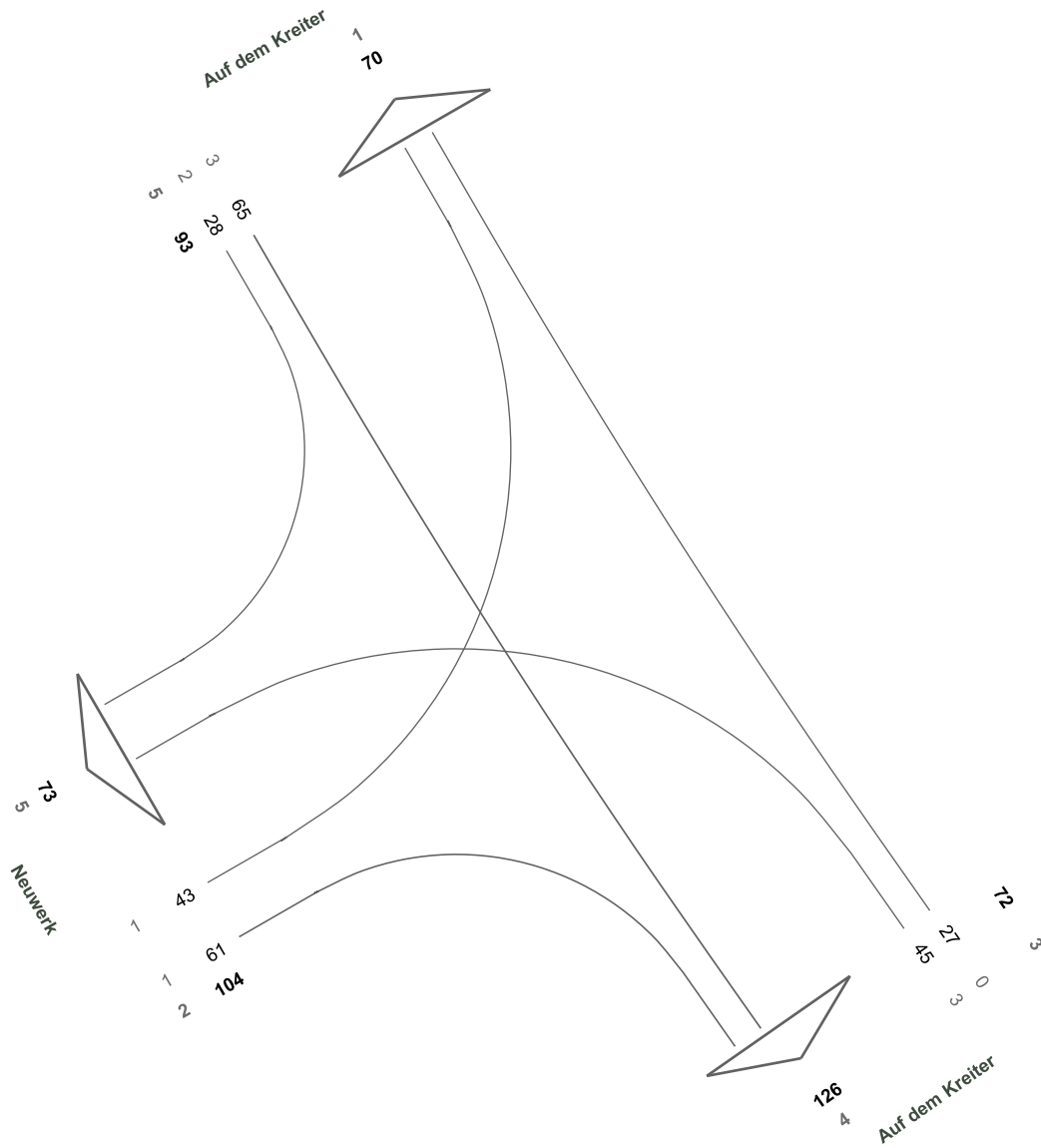

22 - Neuwerk / Auf dem Kreiter

28.11.2017
06:00 - 10:00 Uhr
4-h-Block
Kfz (SV)

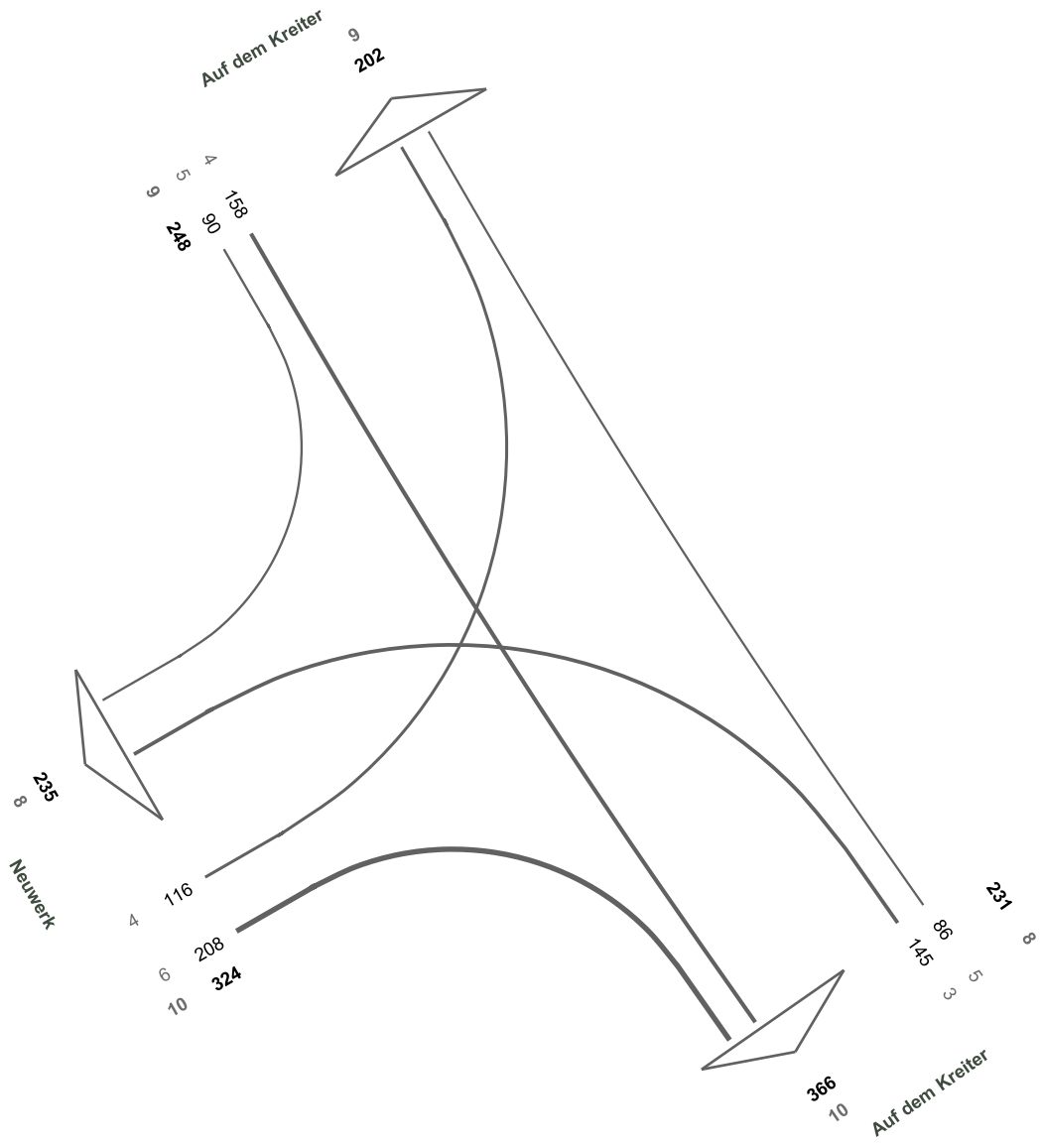

22 - Neuwerk / Auf dem Kreiter

28.11.2017
16:00 - 17:00 Uhr
Abendspitze
Kfz (SV)

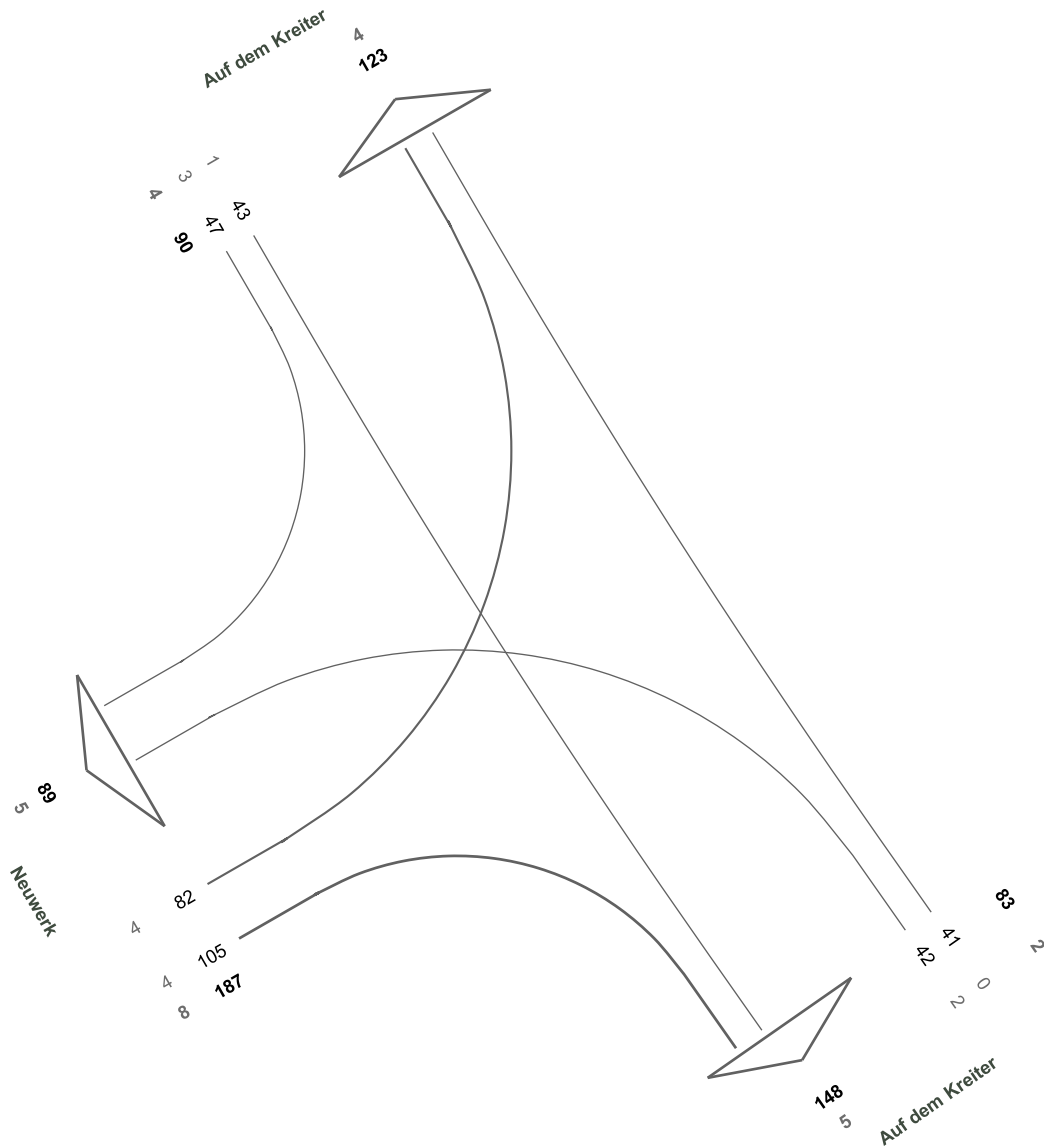

22 - Neuwerk / Auf dem Kreiter

28.11.2017
15:00 - 19:00 Uhr
4-h-Block
Kfz (SV)

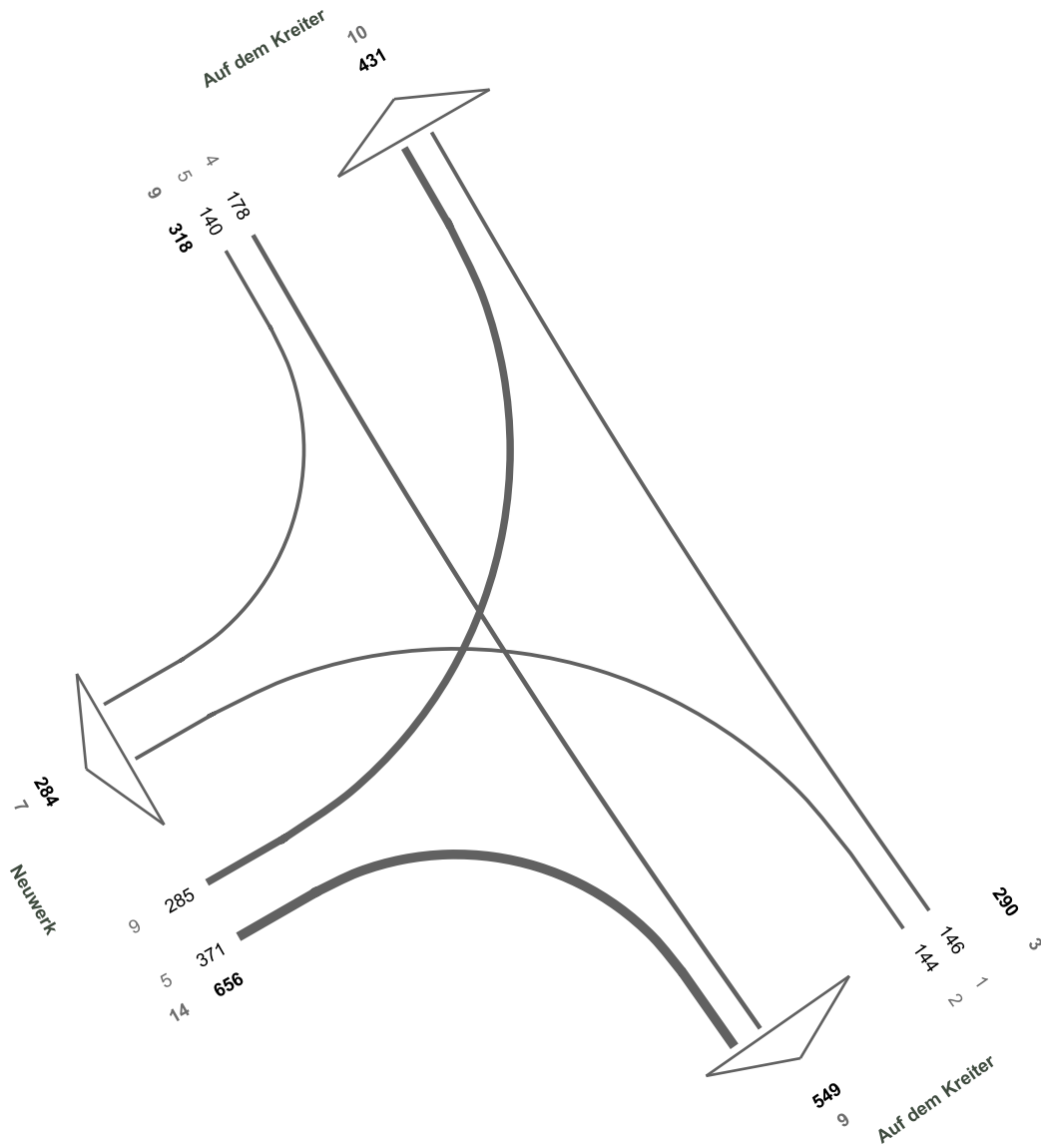

23 - AS Werl Nord A 445

28.11.2017
07:00 - 08:00 Uhr
Morgenspitze
Kfz (SV)

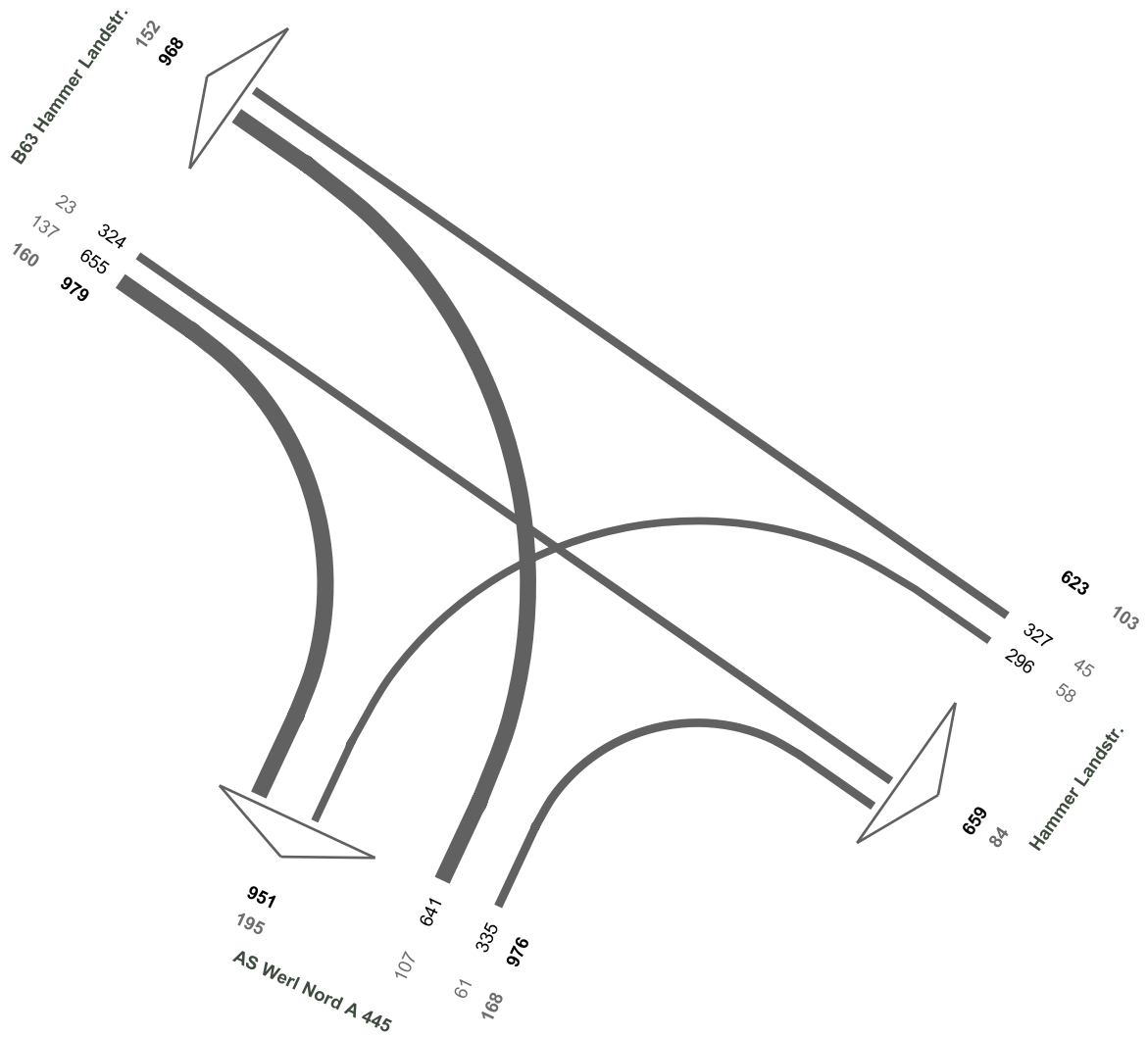

23 - AS Werl Nord A 445

28.11.2017
06:00 - 10:00 Uhr
4-h-Block
Kfz (SV)

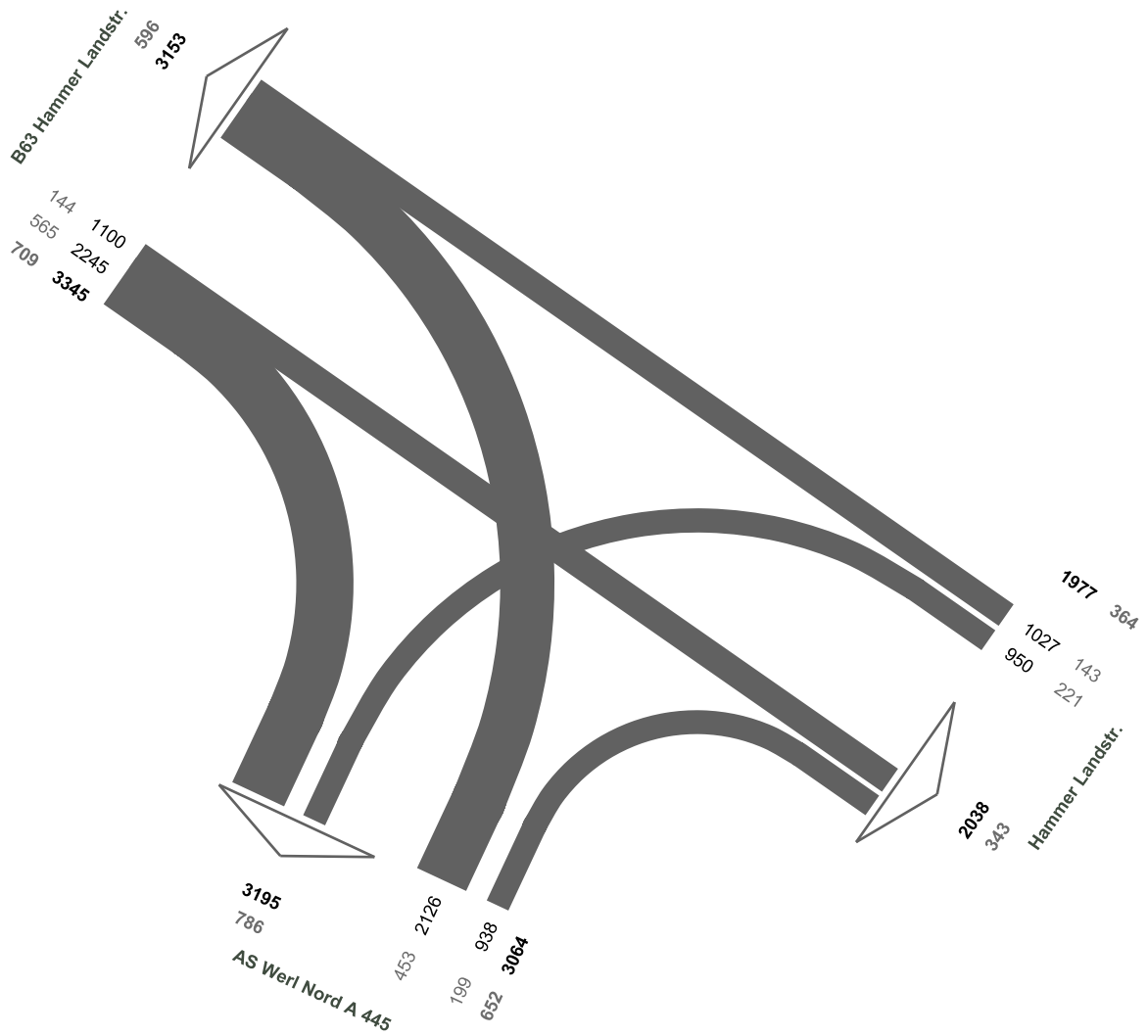

23 - AS Werl Nord A 445

28.11.2017
16:15 - 17:15 Uhr
Abendspitze
Kfz (SV)

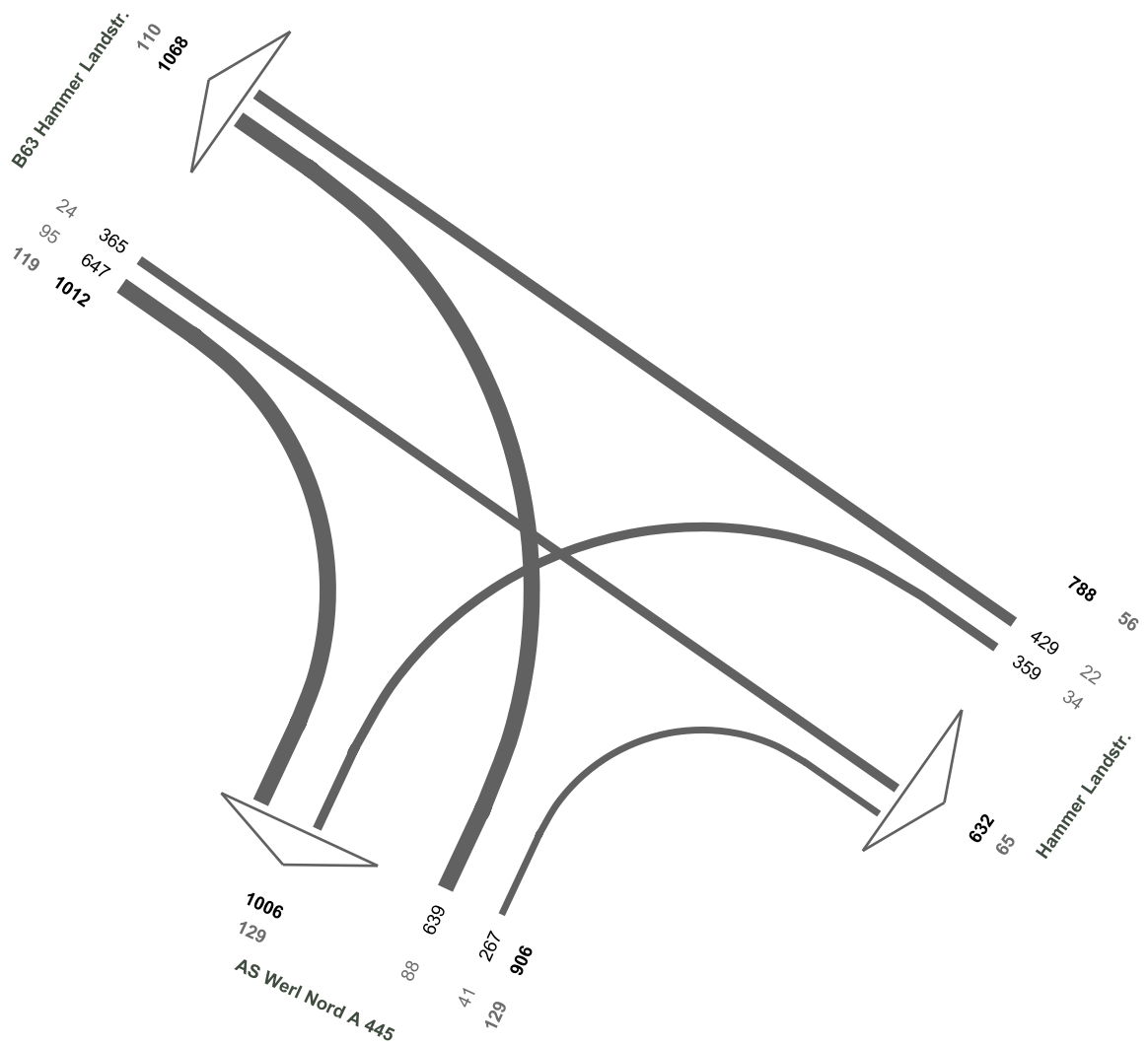

23 - AS Werl Nord A 445

28.11.2017
15:00 - 19:00 Uhr
4-h-Block
Kfz (SV)

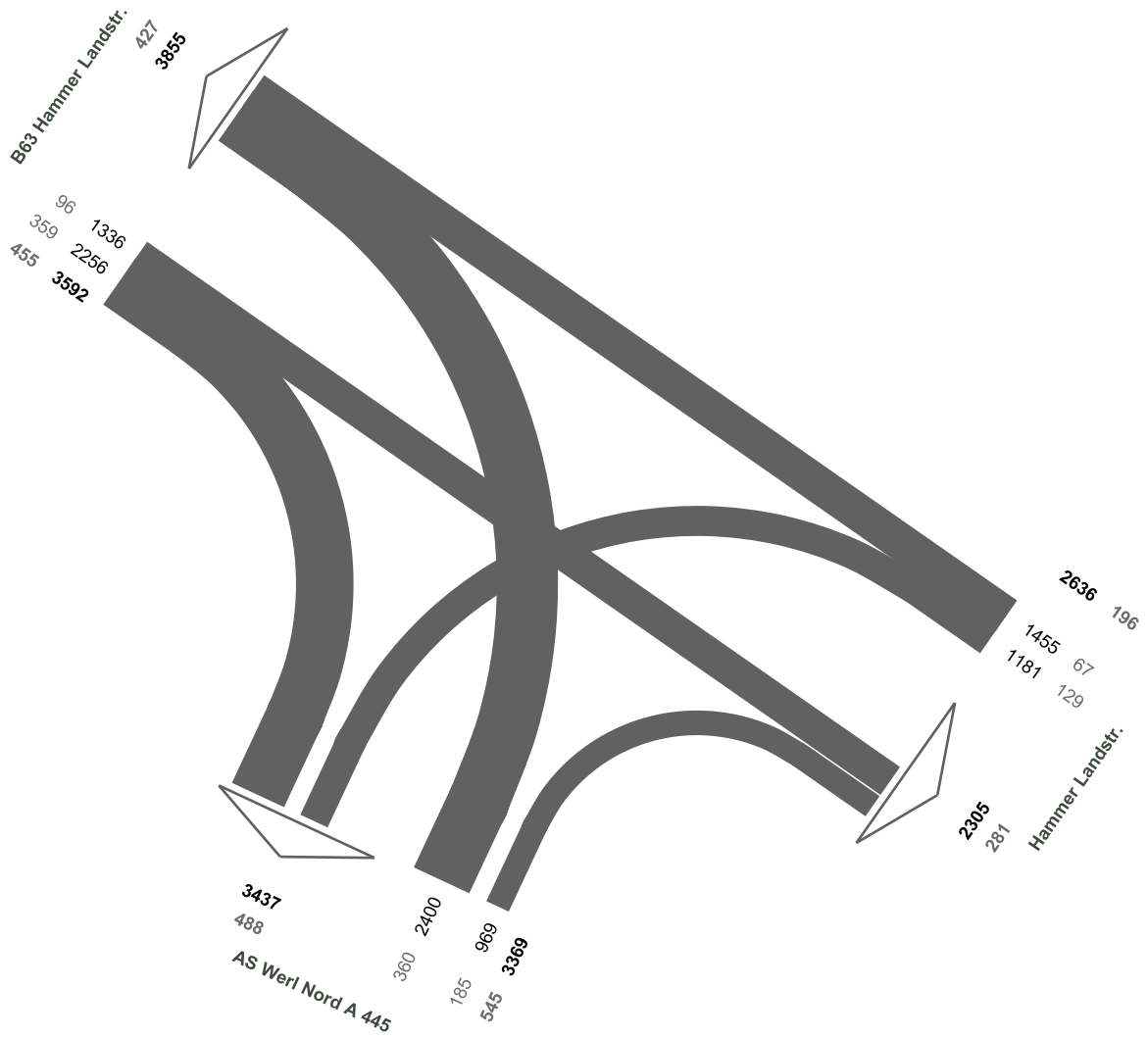

24 - AS A 445 / B1 / L 969

28.11.2017
07:00 - 08:00 Uhr
Morgenspitze
Kfz (SV)

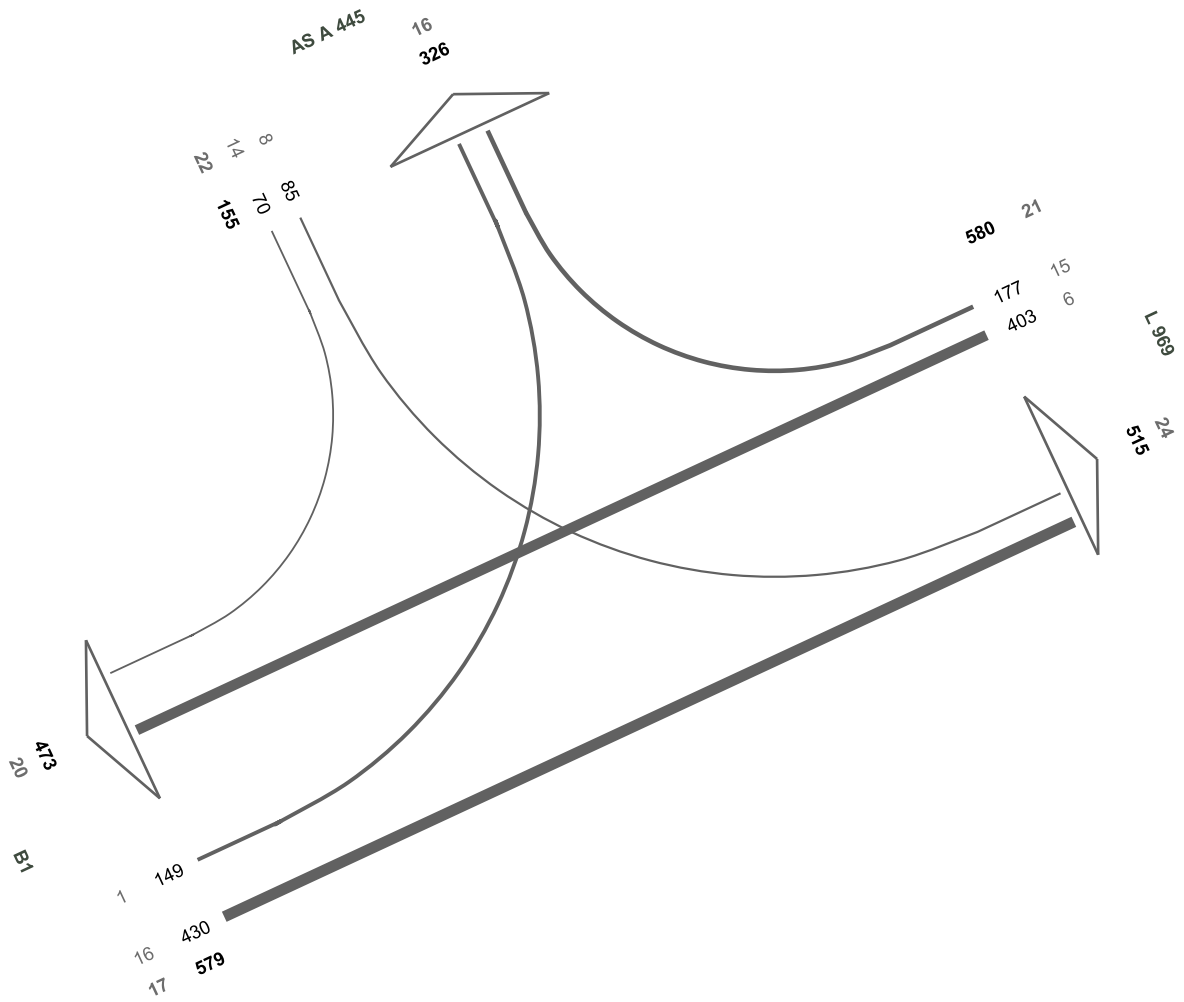

24 - AS A 445 / B1 / L 969

28.11.2017
06:00 - 10:00 Uhr
4-h-Block
Kfz (SV)

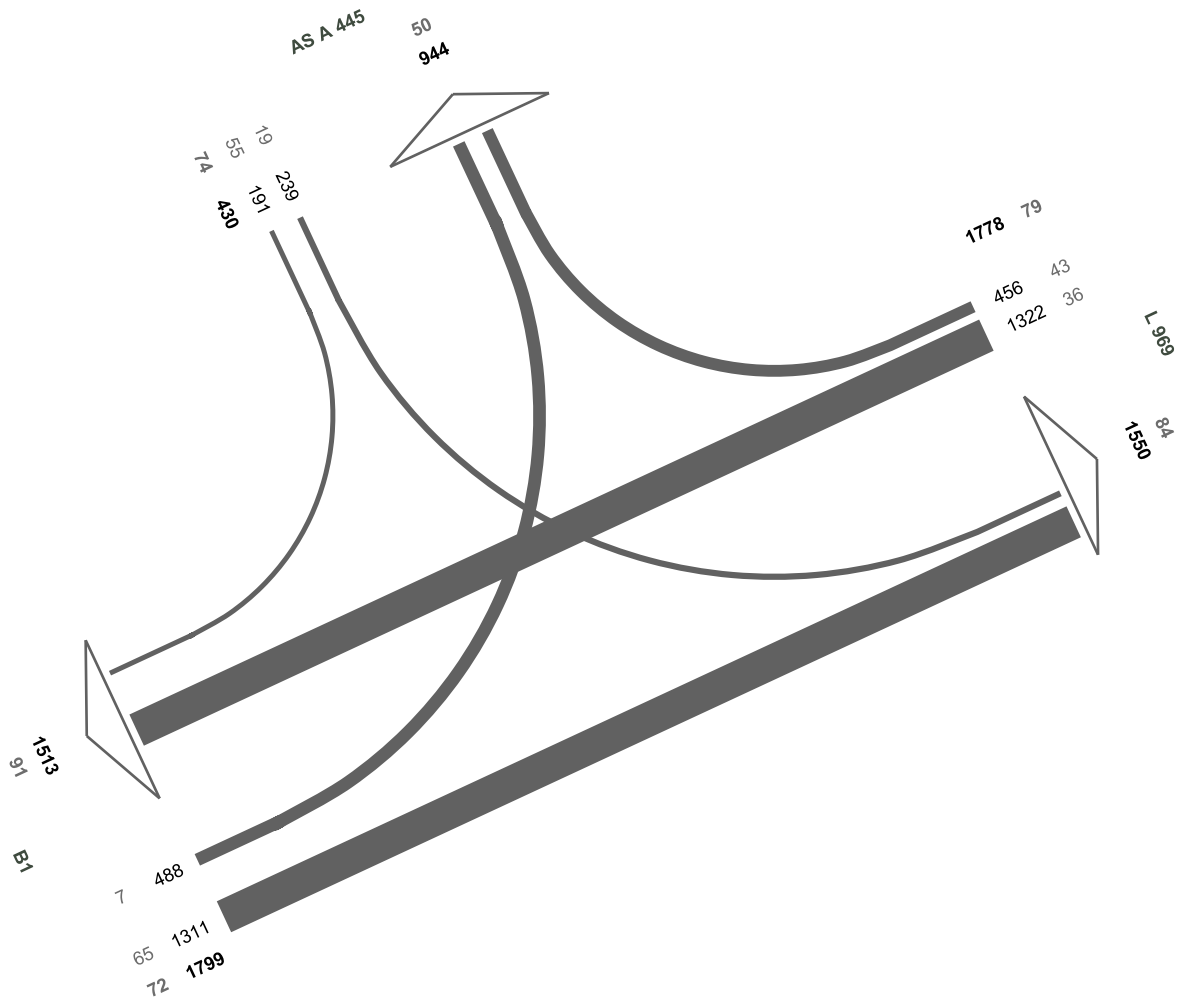

24 - AS A 445 / B1 / L 969

28.11.2017
16:00 - 17:00 Uhr
Abendspitze
Kfz (SV)

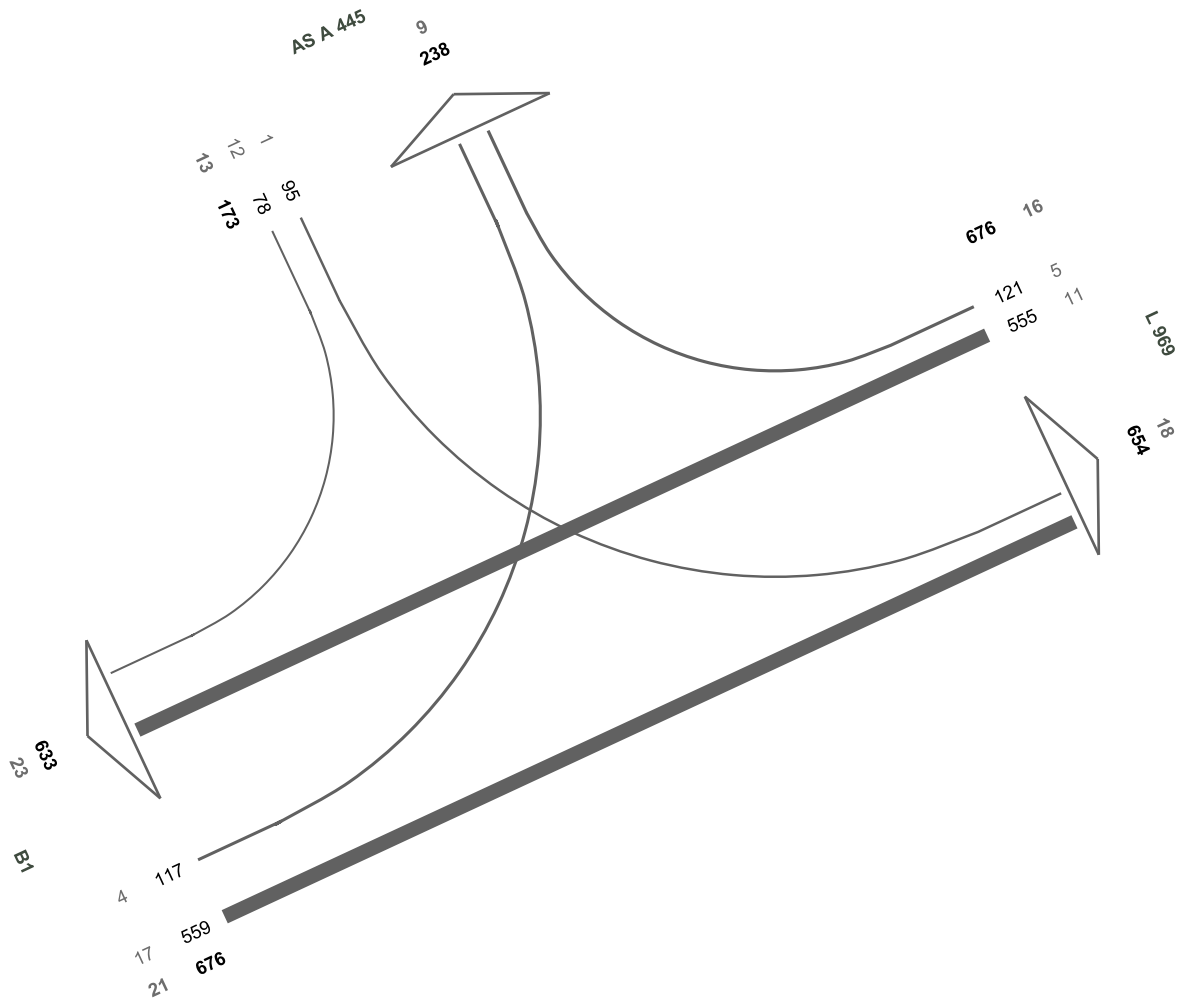

24 - AS A 445 / B1 / L 969

28.11.2017
15:00 - 19:00 Uhr
4-h-Block
Kfz (SV)

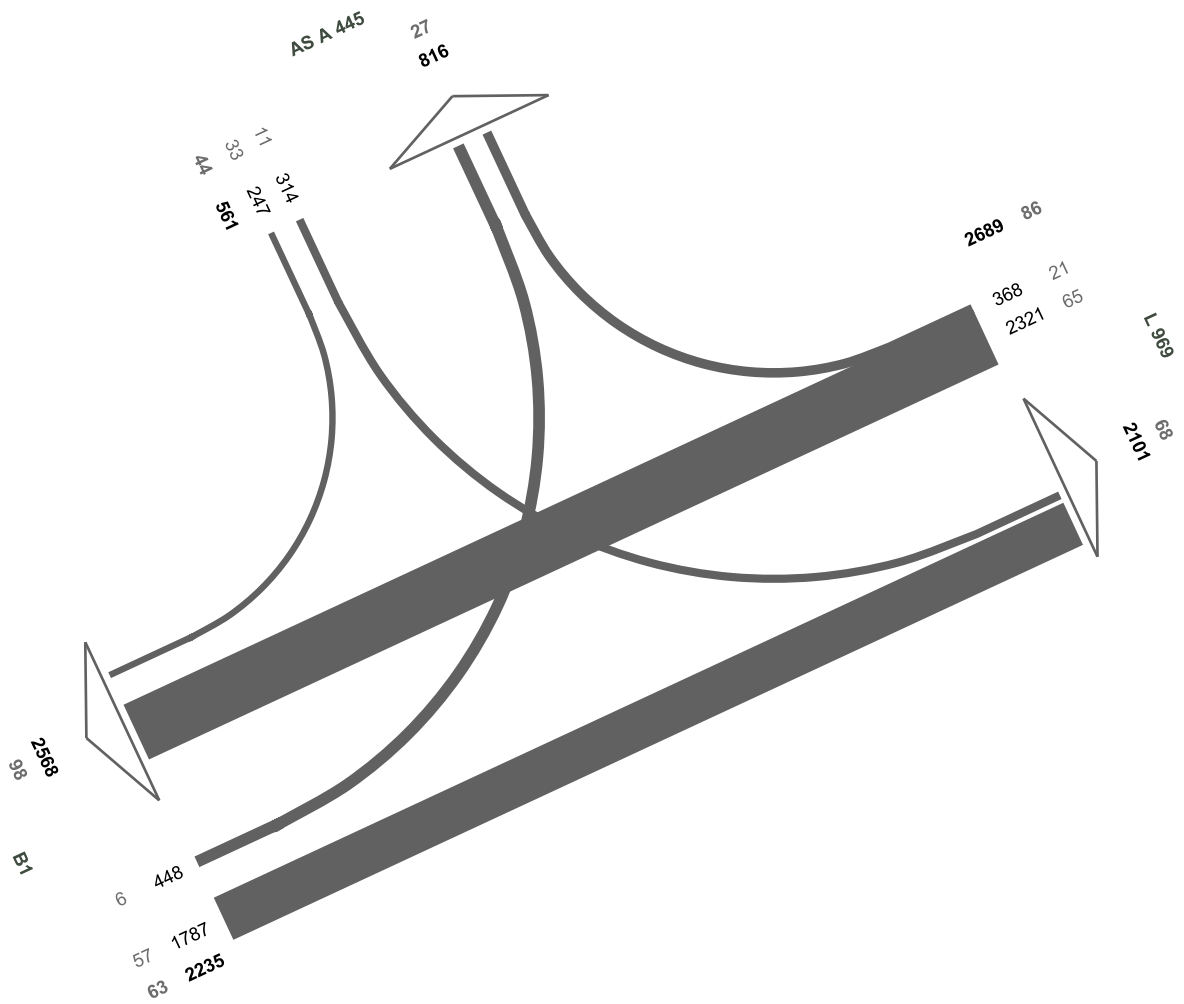

25 - AS A 445 / B1

28.11.2017
07:00 - 08:00 Uhr
Morgenspitze
Kfz (SV)

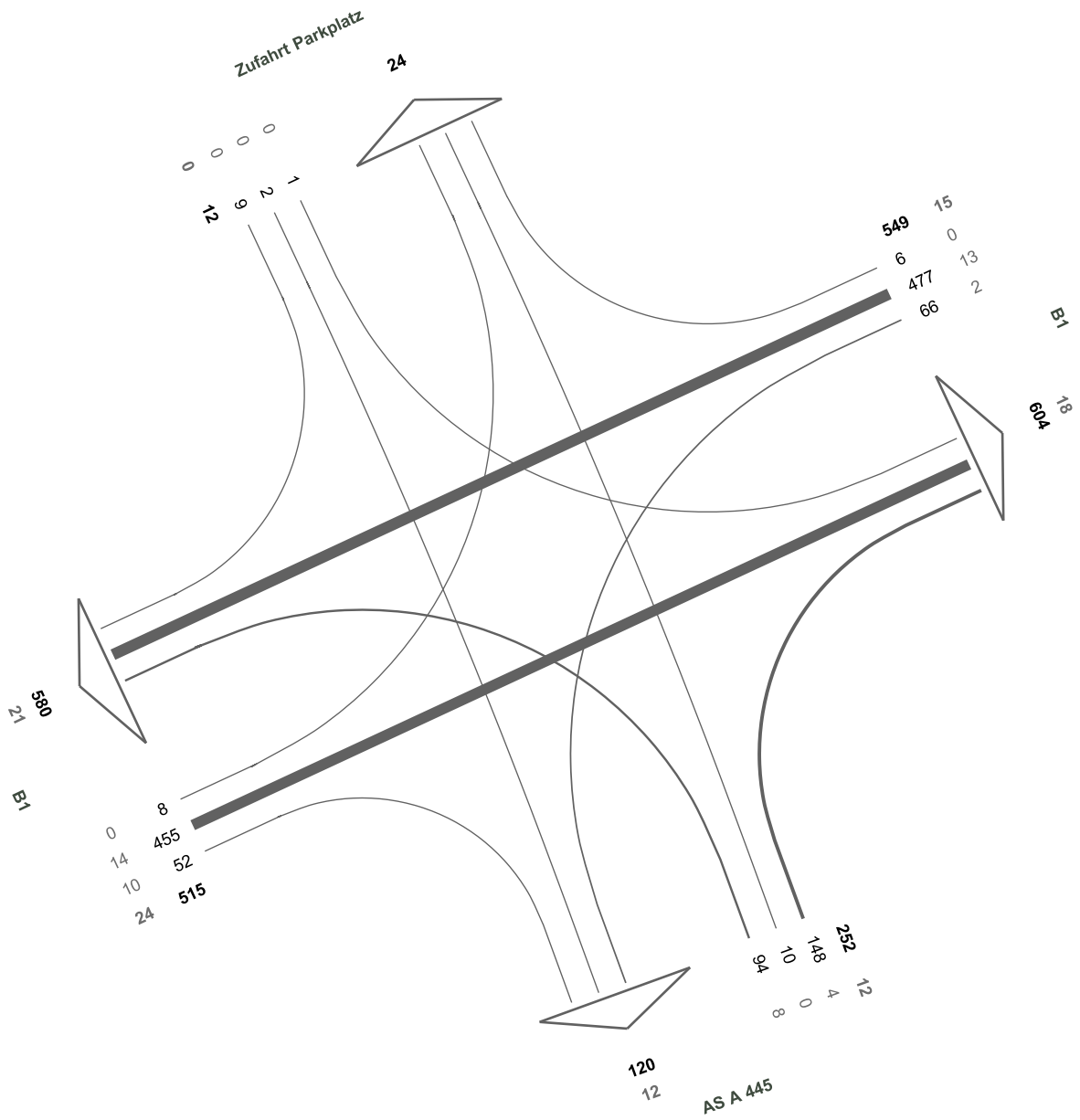

25 - AS A 445 / B1

28.11.2017
06:00 - 10:00 Uhr
4-h-Block
Kfz (SV)

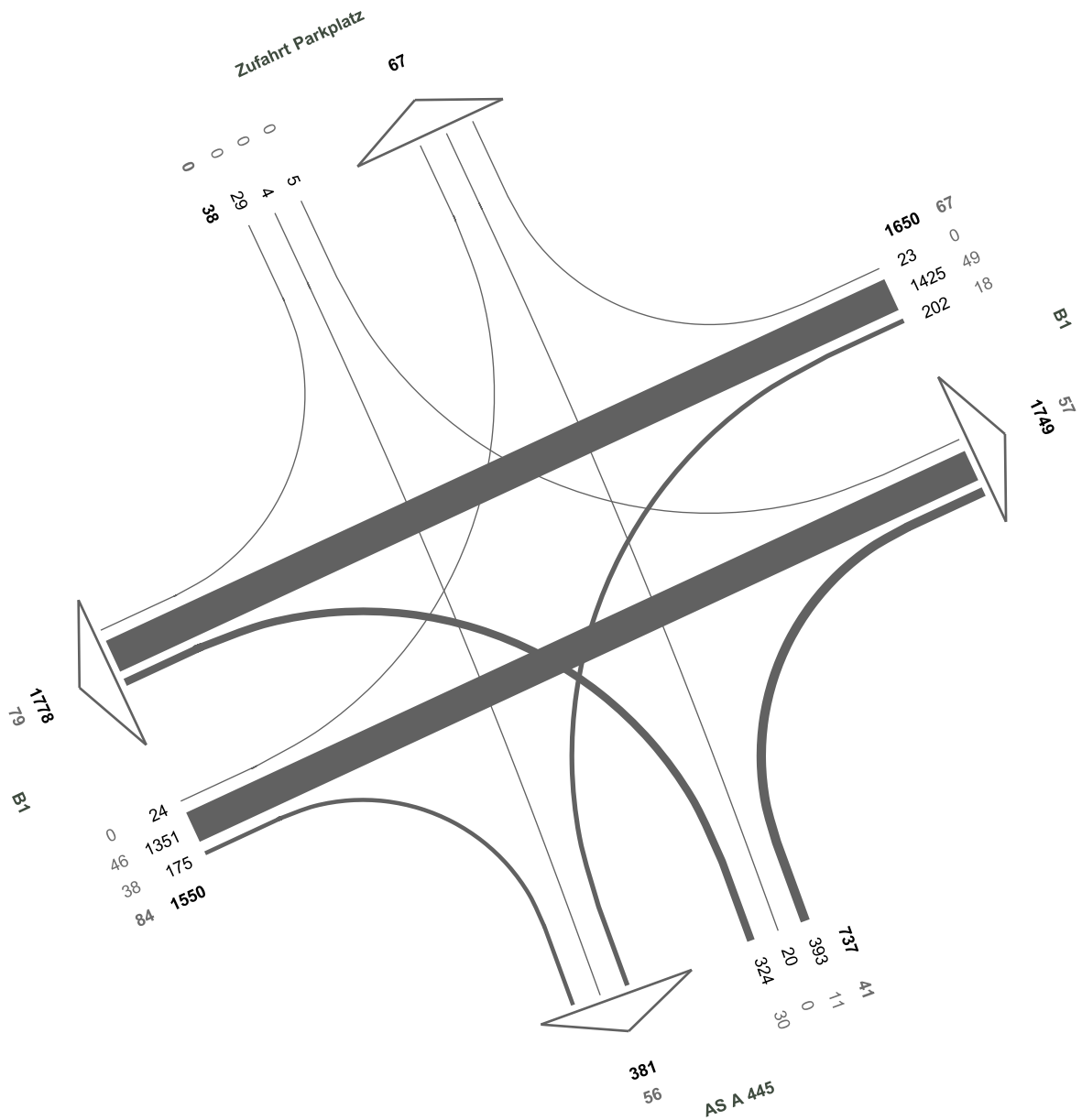

25 - AS A 445 / B1

28.11.2017
16:00 - 17:00 Uhr
Abendspitze
Kfz (SV)

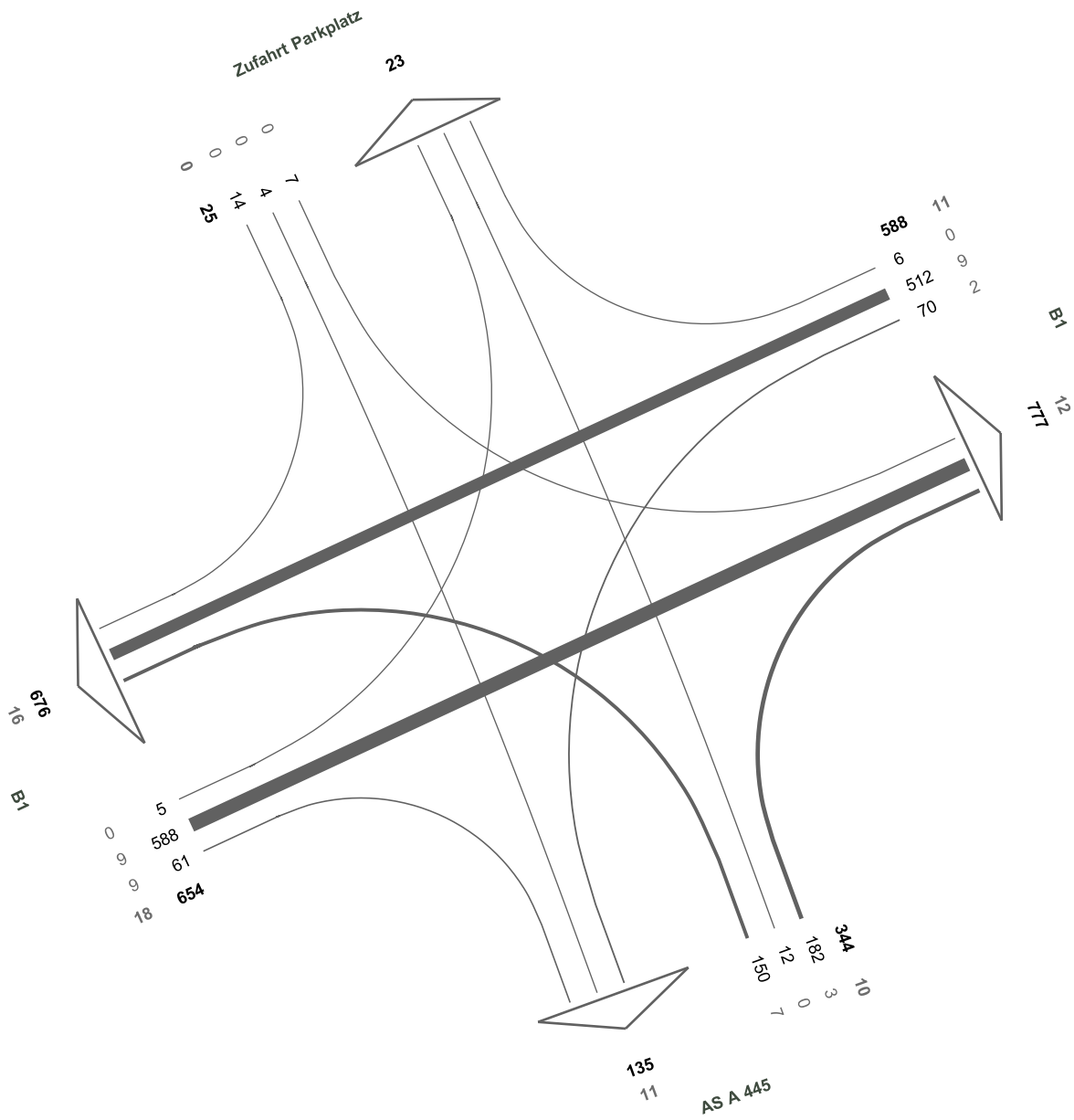

25 - AS A 445 / B1

28.11.2017
15:00 - 19:00 Uhr
4-h-Block
Kfz (SV)

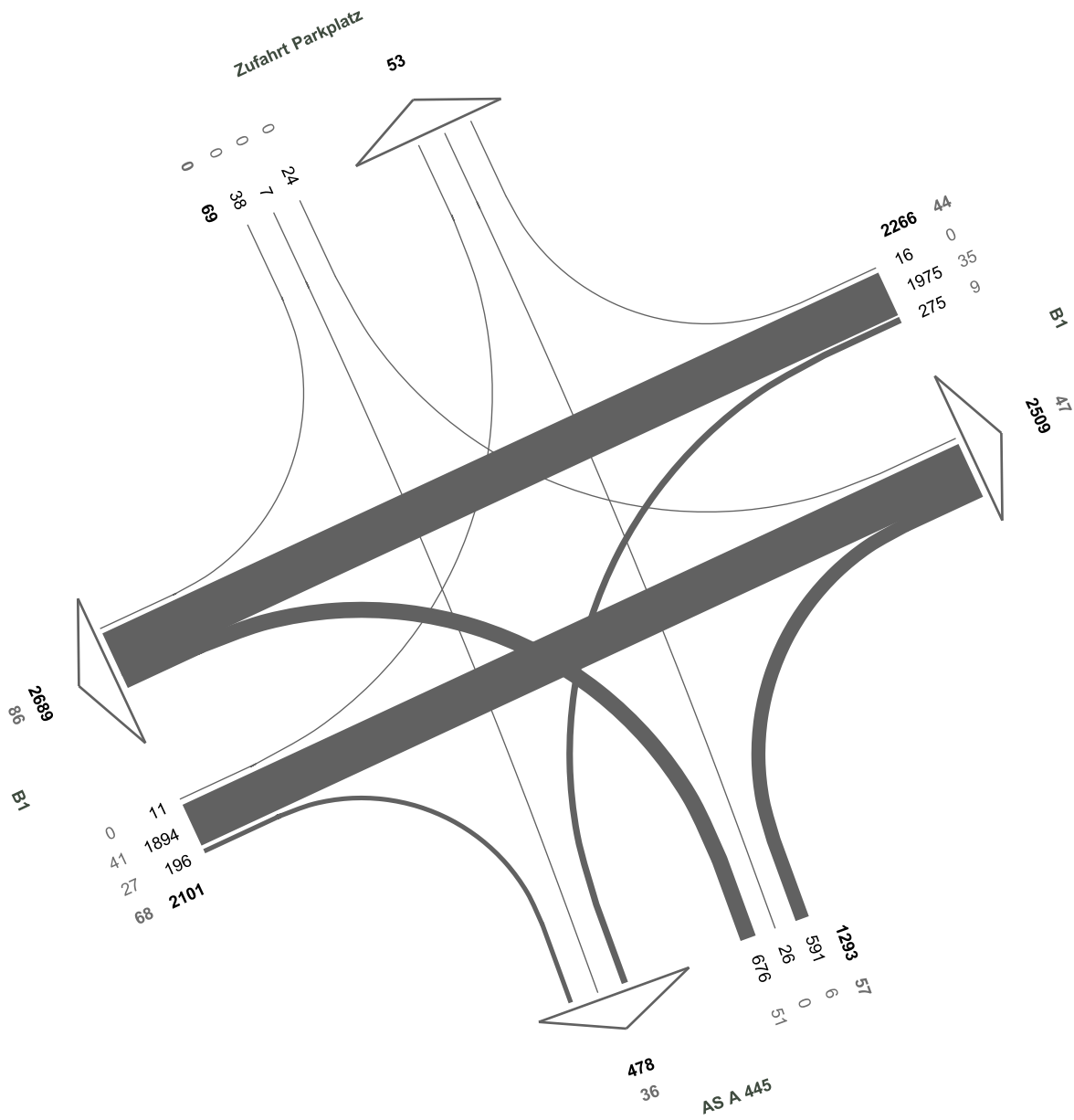

26 - AS A 44 / Neheimer Str.

28.11.2017
07:00 - 08:00 Uhr
Morgenspitze
Kfz (SV)

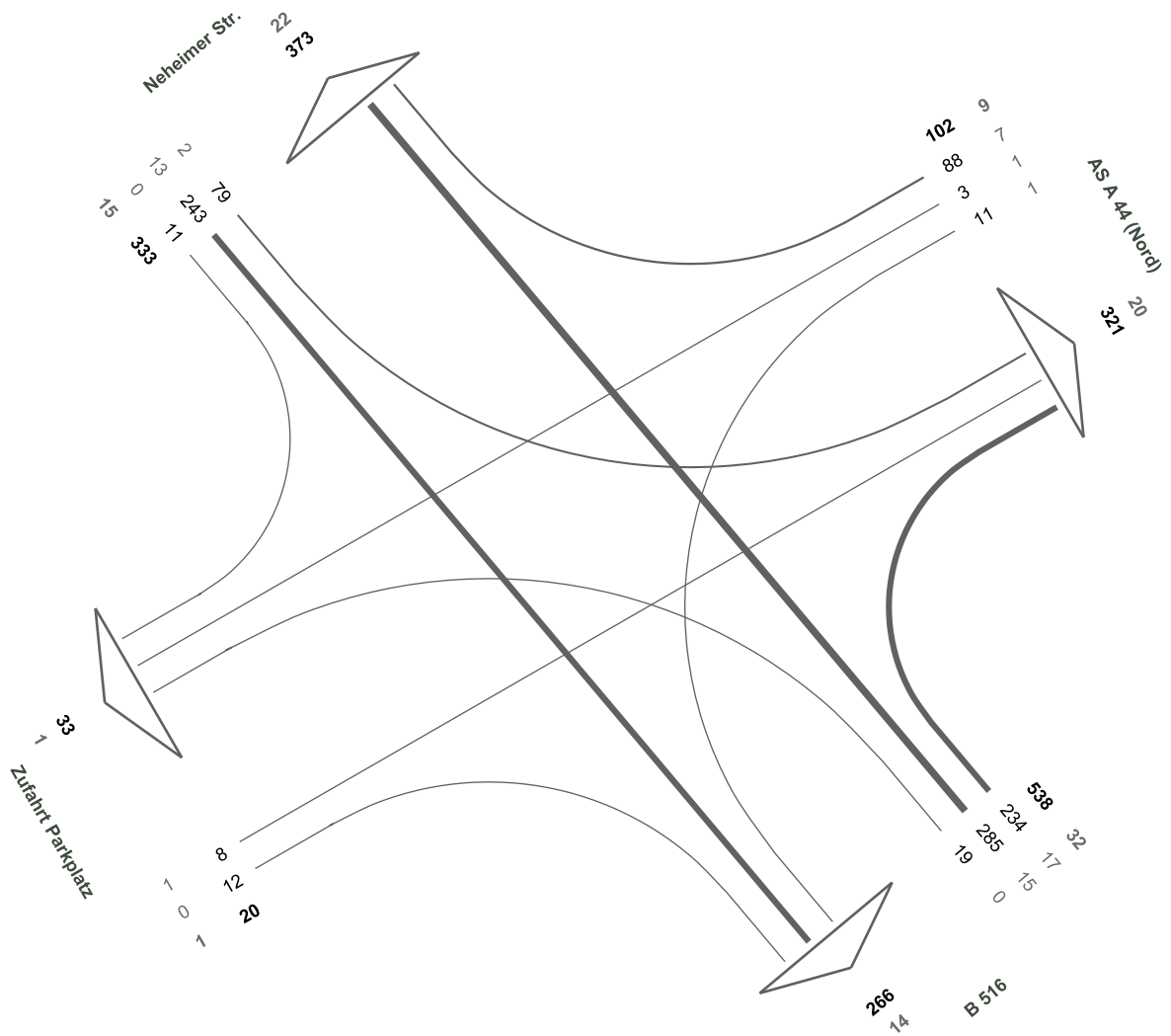

26 - AS A 44 / Neheimer Str.

28.11.2017
16:30 - 17:30 Uhr
Abendspitze
Kfz (SV)

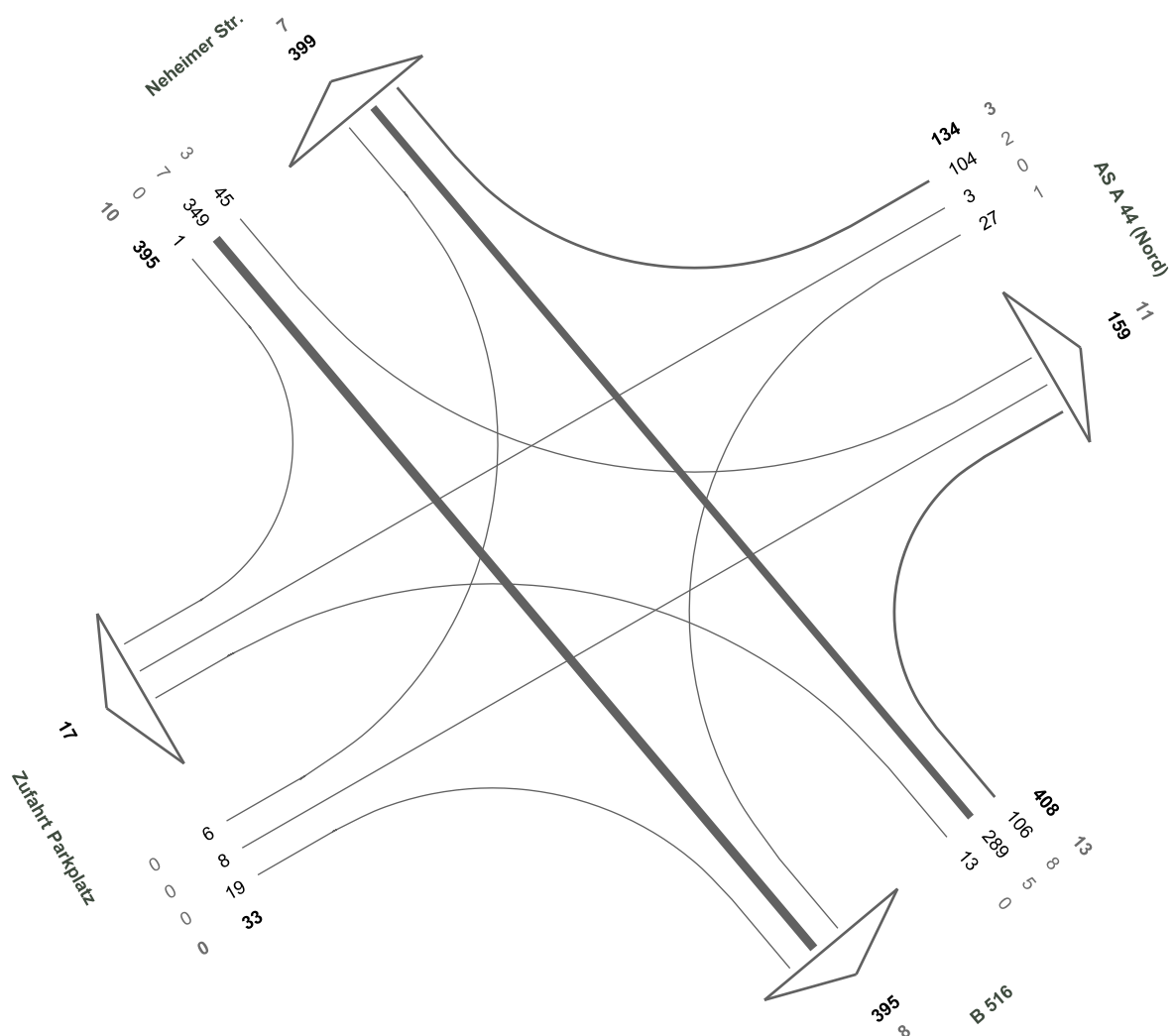

27 - AS A 44 / B 516

28.11.2017
07:00 - 08:00 Uhr
Morgenspitze
Kfz (SV)

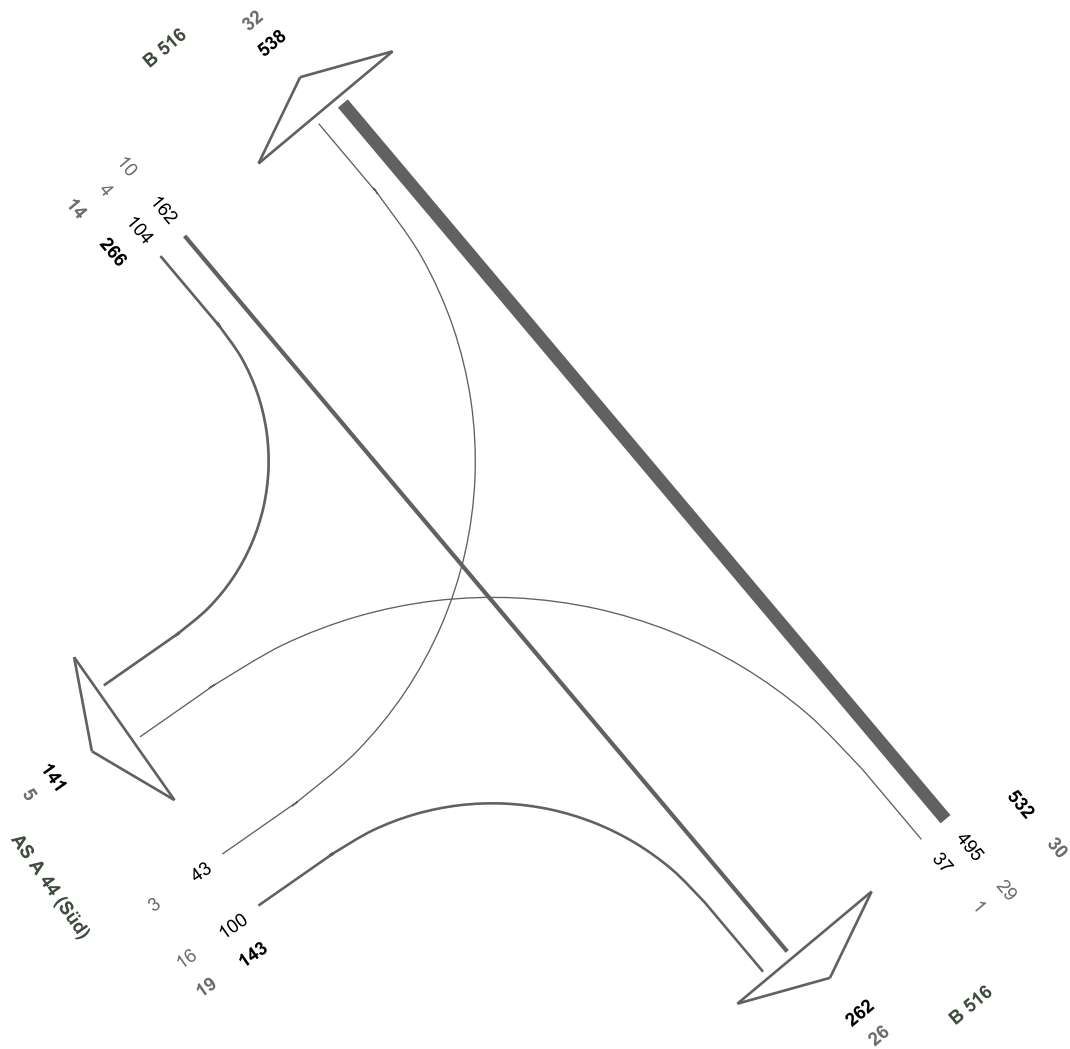

27 - AS A 44 / B 516

28.11.2017
06:00 - 10:00 Uhr
4-h-Block
Kfz (SV)

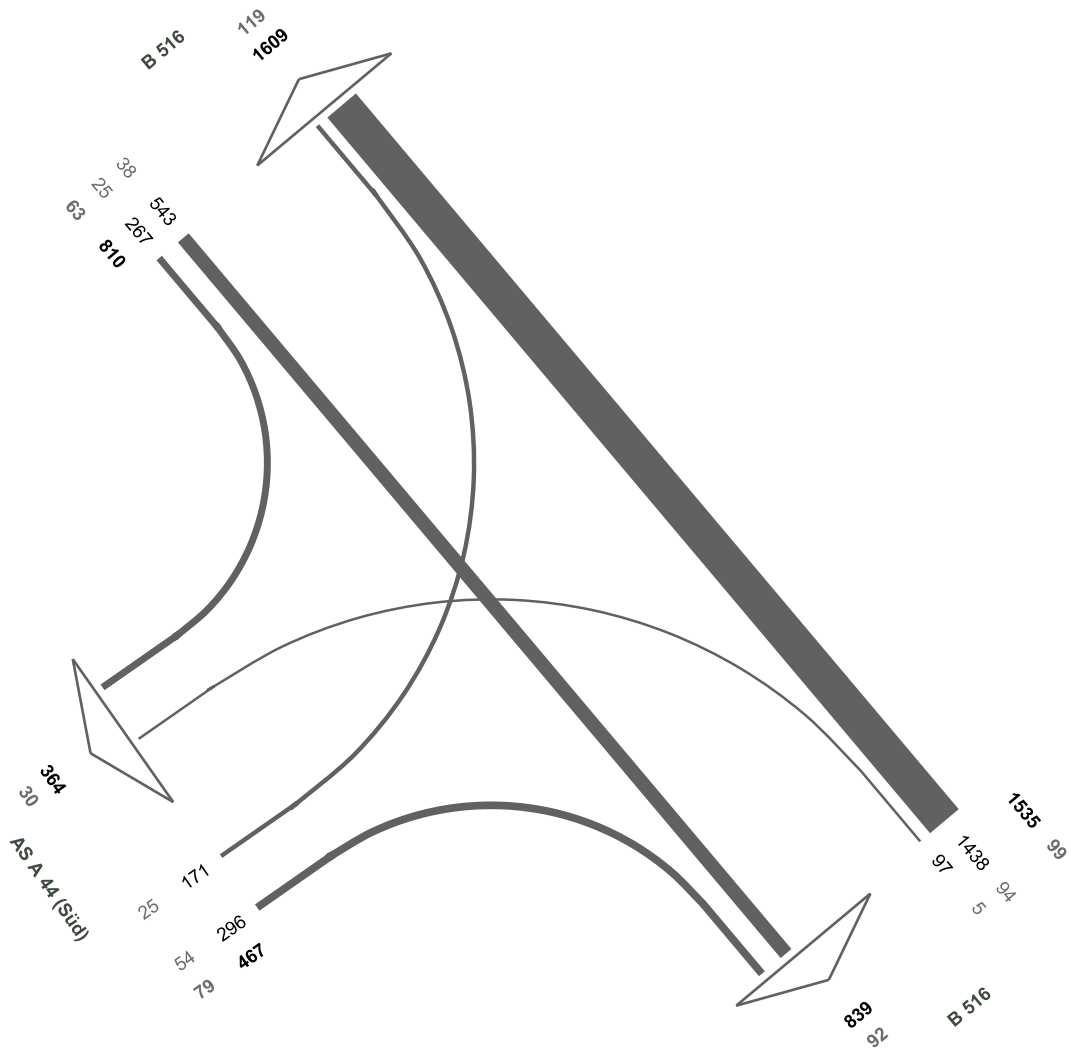

27 - AS A 44 / B 516

28.11.2017
16:15 - 17:15 Uhr
Abendspitze
Kfz (SV)

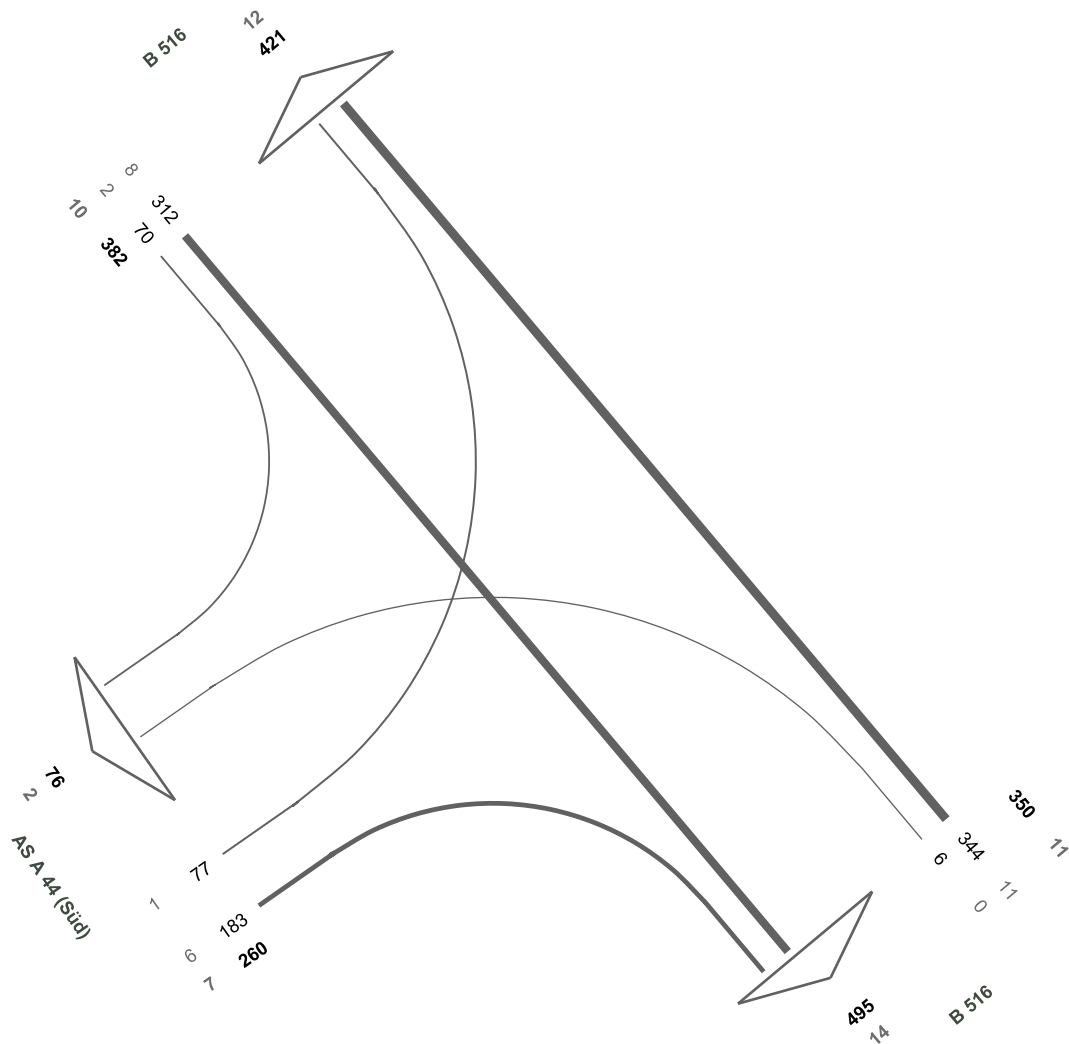

27 - AS A 44 / B 516

28.11.2017
15:00 - 19:00 Uhr
4-h-Block
Kfz (SV)

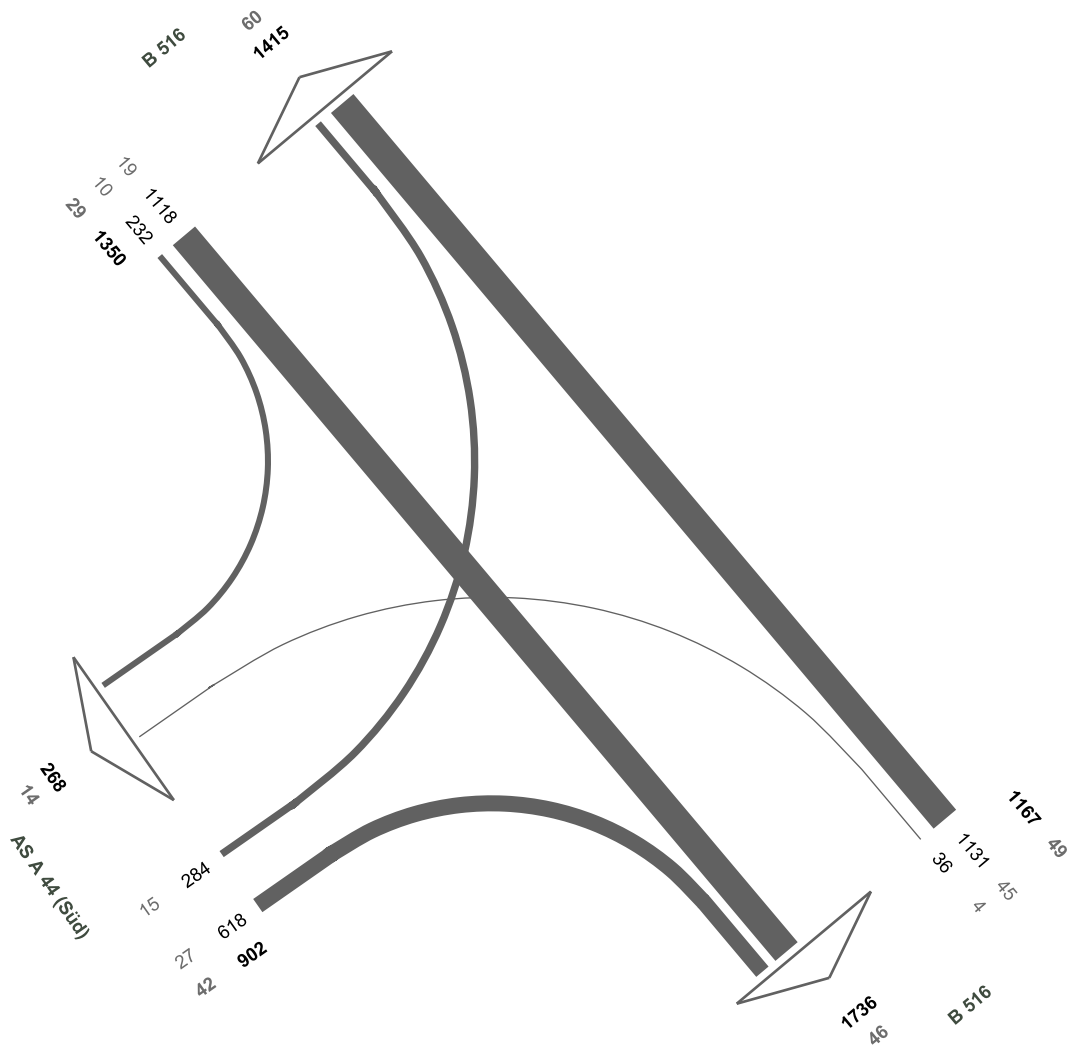

28 - Neuerstraße / Kisastraße

28.11.2017
07:15 - 08:15 Uhr
Morgenspitze
Kfz (SV)

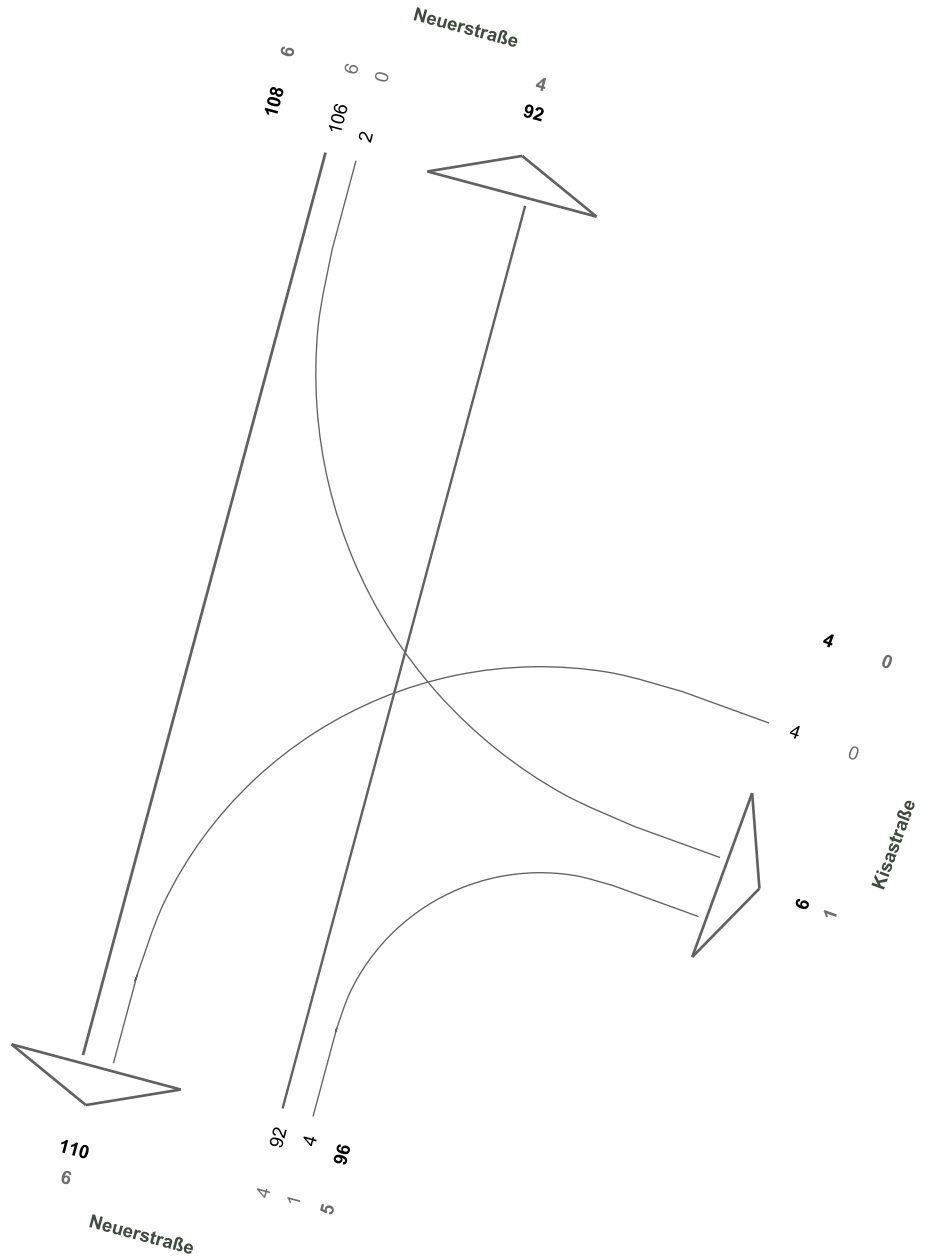

28 - Neuerstraße / Kisastraße

28.11.2017
06:00 - 10:00 Uhr
4-h-Block
Kfz (SV)

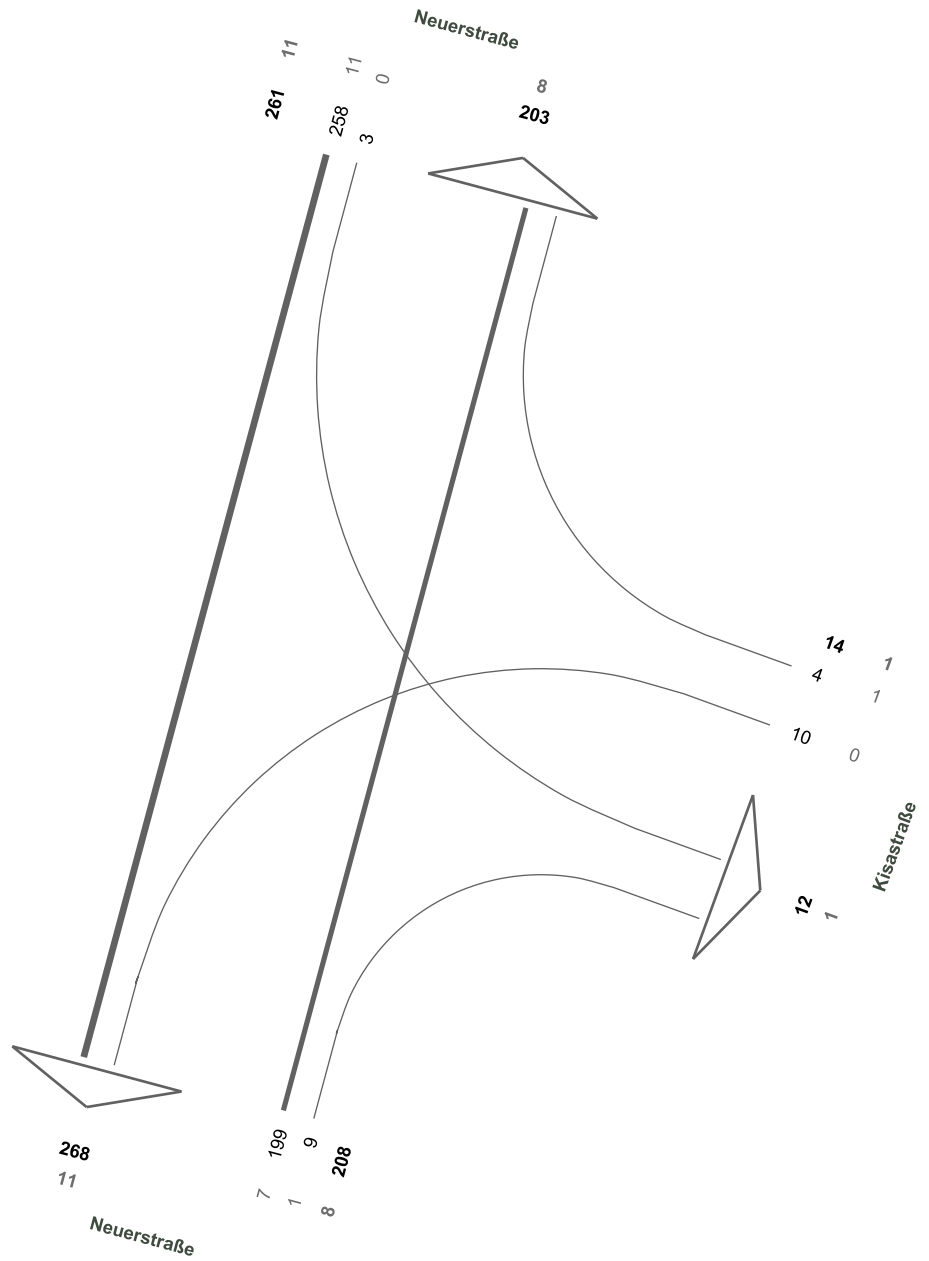

28 - Neuerstraße / Kisastraße

28.11.2017
16:15 - 17:15 Uhr
Abendspitze
Kfz (SV)

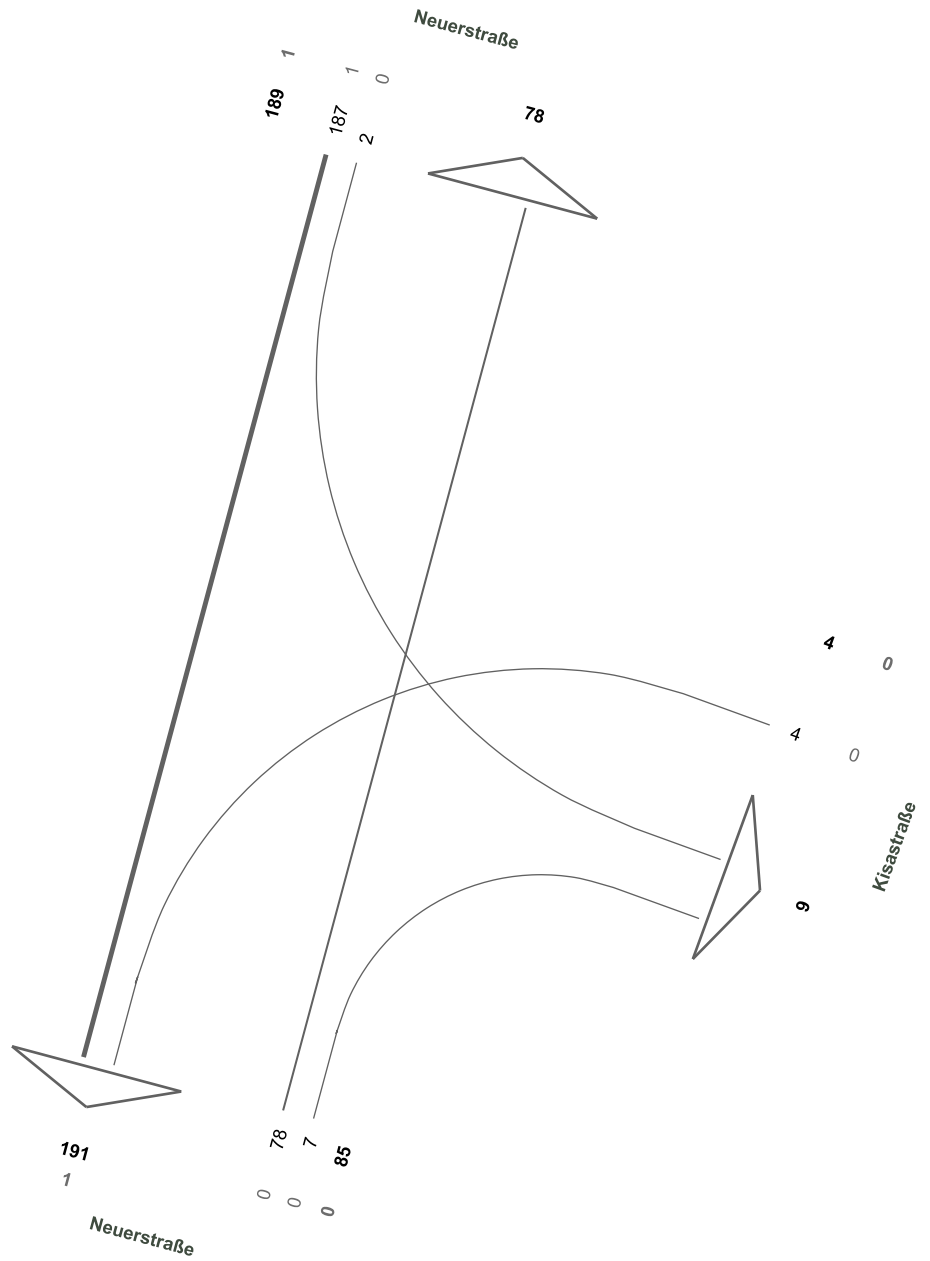

28 - Neuerstraße / Kisastraße

28.11.2017
15:00 - 19:00 Uhr
4-h-Block
Kfz (SV)

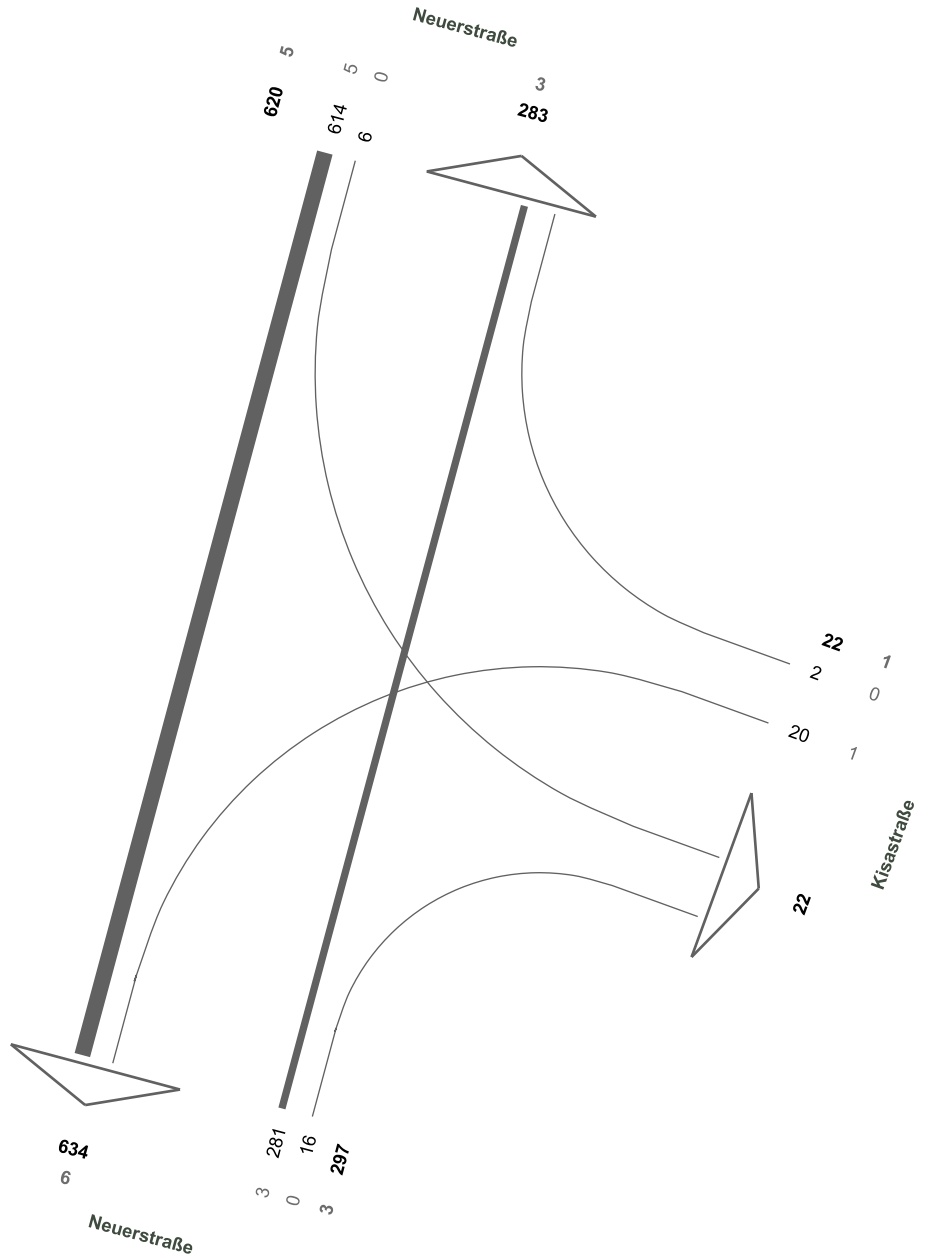

IGS | Ingenieurgesellschaft STOLZ mbH

Hammfelddamm 6
41460 Neuss

T (0 21 31) 79 18 92 - 0
F (0 21 31) 79 18 92 - 30
E info@igs-ing.de

Heinrich-Grüber-Straße 19
12621 Berlin

(030) 70 71 77 - 18
(030) 70 71 77 - 16
www.igs-ing.de